

---

---

## Hydrometry — Cableway systems for stream gauging

*Hydrométrie — Systèmes de suspension par câbles aériens pour le  
jaugeage en rivière*

**iTeh STANDARD PREVIEW**  
**(standards.iteh.ai)**

[ISO 4375:2014](https://standards.iteh.ai/catalog/standards/sist/0c63f71b-4ef3-4f31-9c85-440b0e19c7d2/iso-4375-2014)

<https://standards.iteh.ai/catalog/standards/sist/0c63f71b-4ef3-4f31-9c85-440b0e19c7d2/iso-4375-2014>



**iTeh STANDARD PREVIEW**  
**(standards.iteh.ai)**

[ISO 4375:2014](https://standards.iteh.ai/catalog/standards/sist/0c63f71b-4ef3-4f31-9c85-440b0e19c7d2/iso-4375-2014)

<https://standards.iteh.ai/catalog/standards/sist/0c63f71b-4ef3-4f31-9c85-440b0e19c7d2/iso-4375-2014>



**COPYRIGHT PROTECTED DOCUMENT**

© ISO 2014

All rights reserved. Unless otherwise specified, no part of this publication may be reproduced or utilized otherwise in any form or by any means, electronic or mechanical, including photocopying, or posting on the internet or an intranet, without prior written permission. Permission can be requested from either ISO at the address below or ISO's member body in the country of the requester.

ISO copyright office  
Case postale 56 • CH-1211 Geneva 20  
Tel. + 41 22 749 01 11  
Fax + 41 22 749 09 47  
E-mail [copyright@iso.org](mailto:copyright@iso.org)  
Web [www.iso.org](http://www.iso.org)

Published in Switzerland

# Contents

	Page
Foreword .....	iv
<b>1 Scope .....</b>	<b>1</b>
<b>2 Normative references .....</b>	<b>1</b>
<b>3 Terms and definitions .....</b>	<b>1</b>
<b>4 General description of a cableway system .....</b>	<b>1</b>
4.1 Elements of a cableway system .....	1
4.2 Cableway supports .....	3
4.3 Main track or main cable .....	3
4.4 Anchorage .....	3
4.5 Tow cable for a bankside system .....	3
4.6 Suspension cable .....	3
4.7 Instrument carriage for a bankside system .....	4
4.8 Personnel carriage .....	4
4.9 Winch arrangements for a bankside system .....	4
4.10 Winch arrangements for a personnel carriage .....	4
4.11 Lightning protection .....	4
<b>5 Functional requirements of cableway components .....</b>	<b>4</b>
5.1 Safety factors .....	4
5.2 Cableway supports .....	5
5.3 Selection of main cable or track .....	6
5.4 Anchorage .....	6
5.5 Backstays .....	6
5.6 Tow cable .....	6
5.7 Carriages .....	6
5.8 Winches .....	7
<b>6 Maintenance, examination and testing .....</b>	<b>9</b>
6.1 General examination .....	9
6.2 Routine inspection .....	9
6.3 Static testing .....	9
6.4 Lubrication .....	10
6.5 Checking the sag .....	10
<b>Annex A (informative) Cableway characteristics .....</b>	<b>11</b>
<b>Annex B (informative) Limiting main cable tension in bankside cableways .....</b>	<b>22</b>
<b>Bibliography .....</b>	<b>24</b>

## Foreword

ISO (the International Organization for Standardization) is a worldwide federation of national standards bodies (ISO member bodies). The work of preparing International Standards is normally carried out through ISO technical committees. Each member body interested in a subject for which a technical committee has been established has the right to be represented on that committee. International organizations, governmental and non-governmental, in liaison with ISO, also take part in the work. ISO collaborates closely with the International Electrotechnical Commission (IEC) on all matters of electrotechnical standardization.

The procedures used to develop this document and those intended for its further maintenance are described in the ISO/IEC Directives, Part 1. In particular the different approval criteria needed for the different types of ISO documents should be noted. This document was drafted in accordance with the editorial rules of the ISO/IEC Directives, Part 2. [www.iso.org/directives](http://www.iso.org/directives)

Attention is drawn to the possibility that some of the elements of this document may be the subject of patent rights. ISO shall not be held responsible for identifying any or all such patent rights. Details of any patent rights identified during the development of the document will be in the Introduction and/or on the ISO list of patent declarations received. [www.iso.org/patents](http://www.iso.org/patents)

Any trade name used in this document is information given for the convenience of users and does not constitute an endorsement.

For an explanation on the meaning of ISO specific terms and expressions related to conformity assessment, as well as information about ISO's adherence to the WTO principles in the Technical Barriers to Trade (TBT), see the following URL: Foreword - Supplementary information

The committee responsible for this document is ISO/TC 113, *Hydrometric determinations*, Subcommittee SC 5, *Instruments, equipment and data management*.

This third edition cancels and replaces the second edition (ISO 4375:2000), which has been technically revised.

# Hydrometry — Cableway systems for stream gauging

## 1 Scope

This International Standard defines the requirements for equipment, anchorage, supports and accessories for cableway systems for use in stream gauging. Systems which are operated either entirely from the river bank or from a suspended personnel carriage (also called a “cable car”) are discussed. This International Standard is only applicable to the cableway systems to be used for hydrometric measurements. Should the cableway installation be required to be certified as lifting equipment, other standards or regulations may apply. This International Standard does not concern methods for making a discharge measurement which are described in ISO 748.

## 2 Normative references

The following documents, in whole or in part, are normatively referenced in this document and are indispensable for its application. For dated references, only the edition cited applies. For undated references, the latest edition of the referenced document (including any amendments) applies.

ISO 772, *Hydrometry — Vocabulary and symbols*

ISO 80000-4, *Quantities and units — Part 4: Mechanics*

## 3 Terms and definitions

For the purposes of this document, the terms and definitions given in ISO 772, ISO 80000-4 and the following apply.

### 3.1

#### **cable**

wire rope of simple or complex structure or wire cord, fixed or moving in a cableway system

## 4 General description of a cableway system

### 4.1 Elements of a cableway system

A cableway system can be designed to be operated from the river bank (see [Figures 1](#) and [2](#)) or be designed to be operated from a suspended personnel carriage (see [Figure 3](#)). The general arrangement of the following elements are common to both systems:

- a) towers or cableway supports;
- b) track or main cable;
- c) anchorage;
- d) backstays;
- e) suspension cable.

The main differences are:

- the carriage of a bankside system requires a tow cable;
- a bankside system requires a more complicated winch arrangement;

- the personnel carriage has to provide a safe platform for the operator;
- more stringent design requirements may apply to a system which employs a personnel carriage.

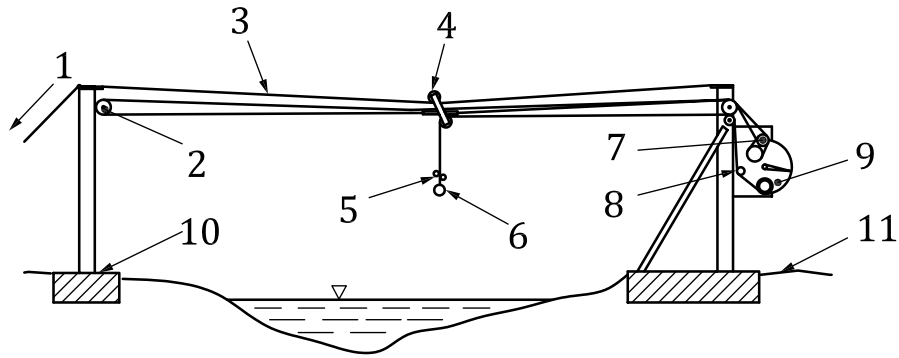

**Key**

- |   |                                      |    |                      |
|---|--------------------------------------|----|----------------------|
| 1 | backstay                             | 7  | distance measurement |
| 2 | traversing cable return pulley       | 8  | depth measurement    |
| 3 | track or main cable                  | 9  | cable drum           |
| 4 | traveller and/or instrument carriage | 10 | footing              |
| 5 | current meter                        | 11 | ground level         |
| 6 | sinker or sounding weight            |    |                      |

iTeh STANDARD PREVIEW

**Figure 1 — Cableway system — Bankside operation, with loop-traversing cable and spooled sounding cable**

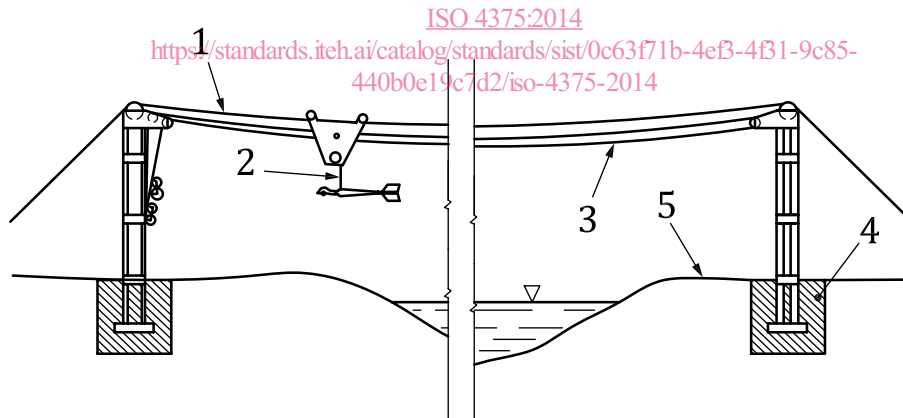

**Key**

- |   |                     |   |              |
|---|---------------------|---|--------------|
| 1 | track or main cable | 4 | footing      |
| 2 | suspension cable    | 5 | ground level |
| 3 | tow cable           |   |              |

**Figure 2 — Cableway system — Bankside operation, with spooled tow cable and spooled sounding cable**

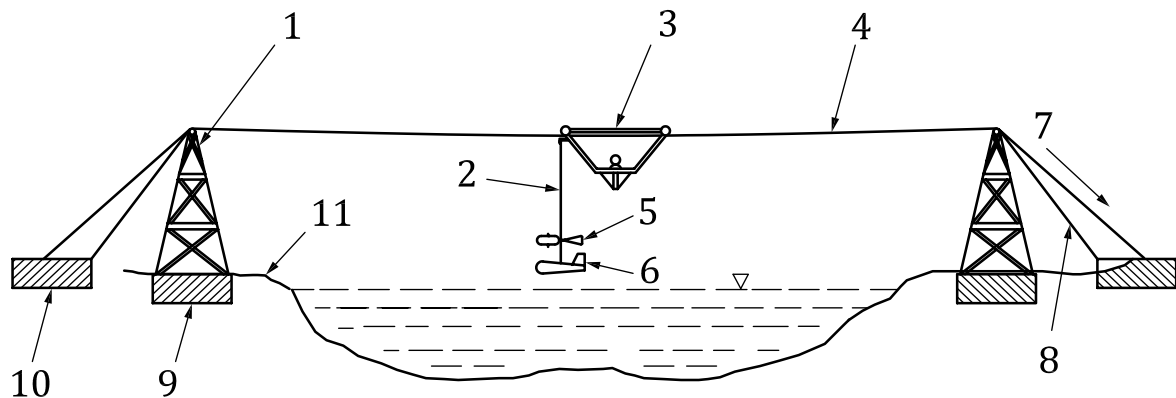
**Key**

1	tower	7	to anchorage
2	suspension cable	8	stayline
3	personnel carriage	9	footing
4	track or main cable	10	anchorage
5	current meter	11	ground level
6	sounding weight		

**Figure 3 — Cableway system — Suspended personnel carriage**

**iTeh STANDARD PREVIEW**

#### 4.2 Cableway supports (standards.iteh.ai)

The cableway supports, one on each bank, support the main cable span across the stream. They may also provide mountings for the winch and the pulleys (sheaves) carrying the tow and suspension cables.

#### 4.3 Main track or main cable

The track or main cable is designed to carry the whole suspended load. The track may be attached directly to stayed cableway supports or be supported on saddles on the cableway supports and led directly to an anchorage.

#### 4.4 Anchorage

Anchorage points are required to carry the loads induced in the cableway and tower system. Depending upon the design of the system, they may be anchorage points for track and backstays or guy-lines, tower foundations subject to compression or tower foundations subject to compression and moment.

#### 4.5 Tow cable for a bankside system

The tow cable is required to move and position the instrument carriage. Generally the tow cable is arranged as an endless loop from the instrument carriage over guiding sheaves on the winch tower, round a driving pulley or drum, across to an idler pulley (sheave) on the tower on the opposite bank and back to the carriage (see [Figure 1](#)). An alternate arrangement uses a spooled tow cable with a single fixing point on the carriage. This arrangement depends upon the equal and opposite force provided by the suspension cable (see [Figure 2](#)).

#### 4.6 Suspension cable

The suspension cable provides the means of raising and lowering sensing or sampling equipment in the stream. The free end of the cable is fitted with connectors to attach equipment and sounding weights. The suspension cable is likely to contain an insulated conducting core to provide a signal path from suspended instruments.

#### 4.7 Instrument carriage for a bankside system

The instrument carriage is provided with one or more track wheels running on the main cable (track), a pulley to support the suspension cable and a point of attachment for the tow (traveller) cable.

#### 4.8 Personnel carriage

The carriage from which gauging observations are made, travels along the main cable. It is suspended from track wheels running on the main cable. The carriage may be moved along the main cable manually or by a power unit. The carriage can be designed to be operated from either the standing or sitting position or both. A cableway employing a personnel carriage shall comply with the safety requirements for passenger cableways where such standards exist specially for horizontal fixed cableways, in all aspects not covered by this International Standard.

#### 4.9 Winch arrangements for a bankside system

A double drum winch is one that provides both traversing and sounding functions within one piece of equipment. One drum controls the suspension cable, the other controls the movement of the carriage. The latter may be a spooling drum or take the form of a friction drive pulley driving an “endless” loop. Both drums may be driven simultaneously in traversing mode or, in sounding mode, the traversing drum may be locked to allow operation of the suspension cable drum only. This operation may also be carried out using two single drum winches. Measuring counters may be fitted to record horizontal and vertical cable movement.

#### 4.10 Winch arrangements for a personnel carriage

A winch (sounding reel) is attached to the carriage (cable car) to raise and lower the sounding weight. The winch is required to operate properly under the load of the sounding weight but both the winch and its mountings should be capable of accommodating the breaking load of the suspension cable with a factor of safety (FoS) of two. The winch may be hand operated or power driven.

#### 4.11 Lightning protection

In areas where electrical storms are considered a risk to cableway operators, provision shall be made to reduce the likelihood of injury from a lightning strike on the cableway system. In countries where lightning is infrequent and lightning protection not considered necessary, work instructions should allow for abandonment of operations in the event of an electrical storm.

### 5 Functional requirements of cableway components

#### 5.1 Safety factors

##### 5.1.1 General

Factors of safety shall be applied to ensure that the equipment is able to cope with normal working without failure and to protect the operator in case of abnormal but foreseeable incidents.

The most likely risk of failure of properly maintained cableway systems lies with the possibility of the suspended equipment becoming caught up on a large floating object. Trees being carried down in a flood are the most likely source of this danger. The excess loading is applied to the system through the suspension cable. In a bankside system, the tension in this cable is equal to, and balanced by, the tension in the “return” side of the tow cable. In both bankside systems and systems with personnel carriages, the load in the suspension cable is also applied to the main cable (track) through the carriage.

For both arrangements, the FoS for normal working shall be achieved by specifying the suspension cable in relation to a maximum working load. The specification of all other cables shall be with respect to the breaking load of the specified suspension cable.



### 5.1.2 Suspension cable

The suspension cable shall be selected to provide a minimum FoS of 5 in relation to the maximum authorized suspended load. The maximum authorized suspended load is the sum of the maximum authorized sounding weight plus an allowance for the mass of sensing/sampling equipment.

### 5.1.3 Tow cable

The tow (traversing) cable shall be selected to provide a FoS of 1,25 with respect to the breaking load of the suspension cable.

### 5.1.4 Track cable

The track cable shall be selected to provide a FoS, with respect to the breaking load of the suspension cable, as follows:

- a) bankside cableway system with instrument carriage: 2
- b) cableway with suspended personnel carriage: 5

### 5.1.5 Marking

Cableways shall be clearly marked to indicate maximum authorized sounding weights and approved suspension cable specification. At an established site, the use of a suspension cable with a breaking load greater than specified at an established site reduces the FoS with respect to the track cable.

(standards.iteh.ai)

## 5.2 Cableway supports

ISO 4375:2014

### 5.2.1 Approaches <https://standards.iteh.ai/catalog/standards/sist/0c63f71b-4ef3-4f31-9c85-440b0e19c7d2/iso-4375-2014>

A safe and convenient approach should be available throughout the year on both banks so that personnel may have easy access to the installation for inspection and operation. It is recognized that access to the far bank may not always be possible in difficult terrain. If this is the case, it should be recognized in the operation procedures for that site.

### 5.2.2 Design load

The cableway supports shall be designed to withstand the breaking load of the track cable selected plus allowance for relevant wind loading. Attention shall be paid to lateral loading as a consequence of drag on the suspended load and allowance made for the extreme condition as the suspension cable approaches breaking point.

### 5.2.3 Foundation placement

The foundation of the tower should extend from below the frost line to at least 300 mm above ground level. The size and design of the foundation is dependent on soil conditions and is beyond the scope of this International Standard.

### 5.2.4 Height

The height of the cableway support shall be such that all parts of the equipment, suspended from the centre of the span, shall be at least 1m above the highest flood level to be measured, but at no time present a hazard to navigation or wildlife. Consideration should also be given to marking the cableway in areas where canoes and aircraft are used in its vicinity. In certain localities, high structures may be governed by regulations requiring the provision of aircraft warning markers or warning lights on the track cable.

### 5.2.5 Corrosion protection

Materials used in the construction of cableway supports shall be protected against corrosion.

## 5.3 Selection of main cable or track

The main cable shall be corrosion resistant. Wire rope may be used for spans up to 300 m. For longer spans it may be necessary to use special cables. Guidance on selecting cable sizes is given in [Annex A](#).

## 5.4 Anchorage

### 5.4.1 Design

Anchorage shall be designed, in accordance with standard engineering practice, to withstand such forces as may be induced upon them at the point of failure of the main cable.

### 5.4.2 Inspection accessibility

The point at which a cable is attached to an anchorage shall be so placed that it can be easily inspected.

## 5.5 Backstays

Backstays provided as part of the tower design shall be of corrosion-resistant steel and be able to withstand the forces developed at the point of failure of the main cable.

## 5.6 Tow cable

Provision shall be made to be able to adjust the tension in a tow cable configured as an endless circuit. The adjuster should be accessible to the operator to allow adjustments to the tension before each use of the cableway.

## 5.7 Carriages

### 5.7.1 Instrument carriage for a bankside system

#### 5.7.1.1 Carriage track wheels

The permissible bending radius of the track cable shall be taken into account in the design of the carriage. This is usually expressed as a multiple of the rope diameter and should be obtained from the rope manufacturer. Where an instrument carriage has more than one track wheel, the design should ensure that the load is distributed equally to each track wheel. Traditional symmetrical triangular designs should be considered to transmit the whole load through a single track wheel.

#### 5.7.1.2 Load requirements

The carriage shall be capable of withstanding a load equivalent to the breaking load of the suspension cable.

#### 5.7.1.3 Carriage design considerations

It shall be simple in design, be designed to be captive on the track and effectively retain the sounding cable in the operational position. It shall be corrosion resistant.

#### 5.7.1.4 Carriage operational requirement

It shall permit the operation of equipment without hindrance.

## 5.7.2 Personnel carriage

### 5.7.2.1 Design

The carriage (cable car) can be designed to be operated and used

- a) in a standing position; or
- b) in a sitting position.

The number of personnel permitted to occupy the carriage shall be clearly indicated on the installation together with the maximum mass of survey equipment and the maximum sounding weight permitted. The materials used in construction should be suitable for operation in the extremes of temperature. This is particularly important in seats and panels which may come into contact with operating personnel. The carriage shall be designed to withstand the breaking load of the suspension cable together with the specified maximum loaded capacity of the carriage, excluding the sounding weight, with a FoS of 2.

### 5.7.2.2 Brake

The carriage shall be provided with a brake or holding device to secure it in any desired position on the main cable for the purpose of taking measurements.

## 5.8 Winches

### 5.8.1 General

**iTeh STANDARD PREVIEW**  
(standards.iteh.ai)

#### 5.8.1.1 Brake

The winch shall be fitted with a load-activated brake so as to hold the suspended load and stop the handle from rotating when the winch handle is released in any mode of operation.

440b0e19c7d2/iso-4375-2014

#### 5.8.1.2 Locking device

The winch shall be provided with a locking device for the purpose of holding suspended instruments at a desired depth, in steps not greater than 20 mm. This locking device may also be the brake specified in [5.8.1.1](#).

#### 5.8.1.3 Cable spooling

The winch shall be designed so as to provide even spooling of cable on the drum.

#### 5.8.1.4 Mechanical advantage

The gearing of a manually wound winch shall be related to the maximum recommended sounding weight, or be adjustable to provide an optimum relationship between effort at the winding handle and pay-out rate. The effort required on the handle to raise the maximum recommended sounding weight should not exceed 90 N.

#### 5.8.1.5 Drum diameter

The diameter of any drum shall not be less than the minimum winding diameter recommended for the cable.

#### 5.8.1.6 Signal transmission

Where the suspension cable is required to have an electrical signal core to transmit signals from the suspended equipment, the winch shall be provided with a method of transmitting these signals to the recording equipment.

### 5.8.1.7 Power winch requirements

Electrically or hydraulically driven winches should be provided with a facility to vary operating speed. In case of power failure, the winch shall be automatically braked or employ a gear train which cannot be driven by the load. It should have provision for manual operation to allow the recovery of equipment. Motor controls should incorporate overload protection and include "soft start" to reduce shock loading. Controls shall require hand pressure for operation and default to "stop" in the absence of hand pressure. Powered winches shall comply with the machinery regulations of the country in which they are installed.

## 5.8.2 Winches in bankside systems

### 5.8.2.1 Torque limiter

To protect the operator in the event of accidental overload, a winch designed for bankside operation should be fitted with a torque limiting facility in the tow-cable drive system, set to slip under a load on the tow cable equal to twice the maximum suspended load. If a separate winch is employed to control the tow cable, it should be fitted with a torque limiter set to slip at a load equal to twice the maximum suspended load.

### 5.8.2.2 Load requirement

The winch shall be able to withstand a loading greater than the breaking load of the suspension cable, applied simultaneously to the suspension cable and the tow cable.

### 5.8.2.3 Cable deployment

The winch shall be designed to ensure that the tow cable and suspension cable are paid out at approximately the same rate.

### 5.8.2.4 Interlocking mechanism

It shall be possible to operate the suspension cable drum independently of the tow (traversing) cable drum for depth positioning. The arrangement for engaging and disengaging the two drums shall incorporate an interlocking mechanism so that the tow- (traversing-) cable drive is immobilized in the sounding mode and connected to the sounding cable drive in the traversing mode. It shall not be possible to achieve an intermediate state that allows the tow-cable drive to free-wheel.

### 5.8.2.5 Mounting design

The mountings used to attach the winch to the tower shall be designed to accommodate a load in shear, equal to six times the breaking load of the suspension cable. This provides a FoS of 3.

## 5.8.3 Winches on personnel carriages

### 5.8.3.1 Torque limiter

The winch controlling the suspension cable from a personnel carriage should be fitted with a torque limiter to allow the drum to turn and pay out cable, without interfering with the operation of the load-activated brake, which should continue to prevent the handle from rotating under overload conditions.

### 5.8.3.2 Release device

The cable termination on the winch shall be such that it will release or break free in the event of the cable becoming fully unwound under overload conditions.