

---

---

**Heat-treated steel tapping screws —  
Mechanical properties**

*Vis à tôle en acier traité thermiquement — Caractéristiques mécaniques*

**iTeh STANDARD PREVIEW**  
**(standards.iteh.ai)**

[ISO 2702:2011](https://standards.iteh.ai/catalog/standards/sist/f6c80fc4-6ea3-4620-809d-d4ac55ab9488/iso-2702-2011)

<https://standards.iteh.ai/catalog/standards/sist/f6c80fc4-6ea3-4620-809d-d4ac55ab9488/iso-2702-2011>



**iTeh STANDARD PREVIEW**  
**(standards.iteh.ai)**

ISO 2702:2011

<https://standards.iteh.ai/catalog/standards/sist/f6c80fc4-6ea3-4620-809d-d4ac55ab9488/iso-2702-2011>



**COPYRIGHT PROTECTED DOCUMENT**

© ISO 2011

All rights reserved. Unless otherwise specified, no part of this publication may be reproduced or utilized in any form or by any means, electronic or mechanical, including photocopying and microfilm, without permission in writing from either ISO at the address below or ISO's member body in the country of the requester.

ISO copyright office  
Case postale 56 • CH-1211 Geneva 20  
Tel. + 41 22 749 01 11  
Fax + 41 22 749 09 47  
E-mail [copyright@iso.org](mailto:copyright@iso.org)  
Web [www.iso.org](http://www.iso.org)

Published in Switzerland

## Foreword

ISO (the International Organization for Standardization) is a worldwide federation of national standards bodies (ISO member bodies). The work of preparing International Standards is normally carried out through ISO technical committees. Each member body interested in a subject for which a technical committee has been established has the right to be represented on that committee. International organizations, governmental and non-governmental, in liaison with ISO, also take part in the work. ISO collaborates closely with the International Electrotechnical Commission (IEC) on all matters of electrotechnical standardization.

International Standards are drafted in accordance with the rules given in the ISO/IEC Directives, Part 2.

The main task of technical committees is to prepare International Standards. Draft International Standards adopted by the technical committees are circulated to the member bodies for voting. Publication as an International Standard requires approval by at least 75 % of the member bodies casting a vote.

Attention is drawn to the possibility that some of the elements of this document may be the subject of patent rights. ISO shall not be held responsible for identifying any or all such patent rights.

ISO 2702 was prepared by Technical Committee ISO/TC 2, *Fasteners*, Subcommittee SC 13, *Fasteners with non-metric thread*.

This third edition cancels and replaces the second edition (ISO 2702:1992), which has been technically revised. In particular, the following modifications have been carried out:

- a) the Scope was expended to ST9,5; [ISO 2702:2011](https://standards.iteh.ai/catalog/standards/sist/6c80546e34620809d44ac55ab9488/iso-2702-2011)
- b) the maximum core hardness was reduced from 390 HV to 370 HV (see 4.1.3); <https://standards.iteh.ai/catalog/standards/sist/6c80546e34620809d44ac55ab9488/iso-2702-2011>
- c) reference to ISO 898-7 concerning torque-measuring device was added (see 6.2.2).

## Introduction

The primary objective of this International Standard is to ensure that tapping screws form mating threads in materials into which they are normally driven without deforming their own thread and without breaking during assembly or service.

# iTeh STANDARD PREVIEW (standards.iteh.ai)

[ISO 2702:2011](https://standards.iteh.ai/catalog/standards/sist/f6c80fc4-6ea3-4620-809d-d4ac55ab9488/iso-2702-2011)

<https://standards.iteh.ai/catalog/standards/sist/f6c80fc4-6ea3-4620-809d-d4ac55ab9488/iso-2702-2011>

# Heat-treated steel tapping screws — Mechanical properties

## 1 Scope

This International Standard specifies the characteristics of heat-treated steel tapping screws, with tapping screw thread from ST2,2 to ST9,5 inclusive according to ISO 1478, together with the corresponding test methods.

## 2 Normative references

The following referenced documents are indispensable for the application of this document. For dated references, only the edition cited applies. For undated references, the latest edition of the referenced document (including any amendments) applies.

ISO 898-7:1992, *Mechanical properties of fasteners — Part 7: Torsional test and minimum torques for bolts and screws with nominal diameters 1 mm to 10 mm*

ISO 6507-1, *Metallic materials — Vickers hardness test — Part 1: Test method*

## 3 Materials

<https://standards.iteh.ai/catalog/standards/sist/f6c80fc4-6ea3-4620-809d-d4ac55ab9488/iso-2702-2011>

Tapping screws shall be made from cold heading, case hardening quality steel.

## 4 Requirements

### 4.1 Metallurgical requirements

#### 4.1.1 Surface hardness

The minimum surface hardness after heat treatment shall be 450 HV 0,3 (see ISO 6507-1).

#### 4.1.2 Case depth

The case depth shall conform to the values given in Table 1.

Table 1 — Case depth

Dimensions in millimetres

Thread	Case depth	
	min.	max.
ST2,2, ST2,6	0,04	0,10
ST2,9, ST3,3, ST3,5	0,05	0,18
ST3,9, ST4,2, ST4,8, ST5,5	0,10	0,23
ST6,3, ST8, ST9,5	0,15	0,28

#### 4.1.3 Core hardness

The core hardness after heat treatment shall be

270 HV 5 to 370 HV 5 for threads  $\leq$  ST3,9, and

270 HV 10 to 370 HV 10 for threads  $\geq$  ST4,2.

#### 4.1.4 Microstructure

The microstructure shall show no band of free ferrite between the case and core.

### 4.2 Mechanical requirements

#### 4.2.1 Thread-forming capability

Tapping screws shall form a mating thread without deforming their own thread when driven into a test plate, in accordance with 6.2.1.

#### 4.2.2 Torsional strength

Tapping screws shall have a torsional strength such that the torque necessary to cause failure, when tested in accordance with 6.2.2, shall equal or exceed the minimum torque values given in Table 3 for the applicable screw threads.

iTeh STANDARD PREVIEW  
(standards.iteh.ai)

## 5 Acceptance

For routine acceptance tests, the drive test, torsional test and core hardness test may be used, but for referee purposes all requirements specified in this International Standard shall be satisfied.

## 6 Test methods

### 6.1 Test methods for the metallurgical requirements

#### 6.1.1 Surface hardness test

The Vickers hardness test shall be carried out in accordance with ISO 6507-1.

The impression of the pyramid shall be made on a flat face, preferably on the screw head.

#### 6.1.2 Case depth — Microscopic test

Case depth shall be measured at the thread flank mid-point between crest and root or, in the case of smaller tapping screws up to ST3,9, in the root of the thread.

For referee purposes, a micro hardness plot shall be made using a Vickers indenter and a 300 g load on the thread profile of a properly prepared metallographic specimen. The case depth shall be the point at which the hardness recorded is 30 HV above the actual core hardness.

#### 6.1.3 Core hardness test

The Vickers core hardness test shall be carried out in accordance with ISO 6507-1 at the mid-radius of a transverse section through the screw taken at a distance sufficiently behind the point of the screw to be through the full minor diameter.

#### 6.1.4 Microstructure test

The microstructure test shall be carried out by metallographic examination.

## 6.2 Test methods for the mechanical requirements

### 6.2.1 Drive test

The sample screw (coated or uncoated, as received) shall be driven into a test plate until a thread of full diameter is completely through the test plate.

The test plate shall be made from low carbon steel with a carbon content not exceeding 0,23 %. The hardness of the plate shall be 130 HV to 170 HV measured in accordance with ISO 6507-1. The thickness of the plate shall conform to the values given in Table 2.

The test hole shall be drilled, or punched and redrilled, or reamed to the hole diameter specified in Table 2 for the size of screw being tested.

**Table 2 — Standard test plate thickness and hole diameter for drive test**

Dimensions in millimetres

Thread	Plate thickness		Hole diameter	
	min.	max.	min.	max.
ST2,2	1,17	1,30	1,905	1,955
ST2,6	1,17	1,30	2,185	2,235
ST2,9	1,17	1,30	2,415	2,465
ST3,3	1,17	1,30	2,68	2,73
ST3,5	1,85	2,06	2,92	2,97
ST3,9	1,85	2,06	3,24	3,29
ST4,2	1,85	2,06	3,43	3,48
ST4,8	3,10	3,23	4,015	4,065
ST5,5	3,10	3,23	4,735	4,785
ST6,3	4,67	5,05	5,475	5,525
ST8	4,67	5,05	6,885	6,935
ST9,5	4,67	5,05	8,270	8,330

In cases where screws are plated subsequent to delivery to the purchaser (or where plating of screws is otherwise under the control of the purchaser), the producer is not responsible for failure due to plating. In such cases, the screw manufacturer can only be held responsible if it is proved that the failure is not due to any post-treatment. Screws from which the plating has been stripped off cannot be considered as samples.

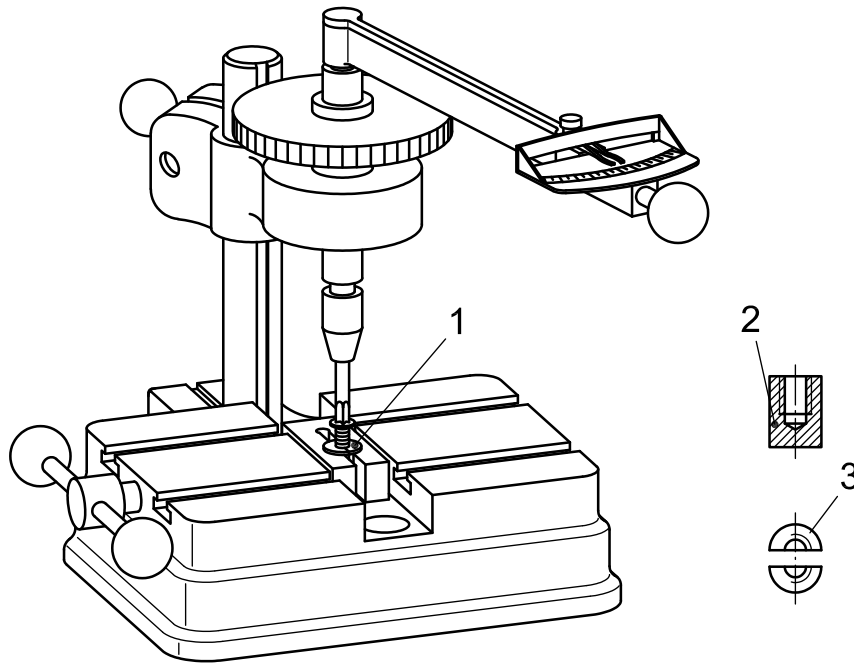

**Key**

- 1 split threaded die or threaded insert
- 2 threaded insert with a blind hole
- 3 split threaded die

iTeh STANDARD PREVIEW  
(standards.iteh.ai)

**Figure 1 — Torsional test apparatus**

**6.2.2 Torsional strength test**

ISO 2702:2011

[https://standards.iteh.ai/catalog/standards/sist/f6c80fc4-6ea3-4620-809d-](https://standards.iteh.ai/catalog/standards/sist/f6c80fc4-6ea3-4620-809d-d4e55ab9488/iso-2702-2011)

The shank of the sample screw (coated or uncoated, as received) shall be clamped in a mating, split, threaded die or other device so that the clamped portion of the screw is not damaged and at least two full threads project above the clamping device and at least two full-form threads exclusive of point are held within the clamping device. A threaded insert with a blind hole may be used in place of the clamping device (see Figure 1) provided the hole depth is such as to ensure that breakage occurs beyond the point.

By means of a suitable calibrated torque-measuring device (in accordance with ISO 898-7:1992, 3.2.2), torque shall be applied to the screw until failure occurs. The screw shall meet the minimum torsional strength requirements given in Table 3.



Table 3 — Torsional strength

Thread	Minimum torsional strength
	N·m
ST2,2	0,45
ST2,6	0,9
ST2,9	1,5
ST3,3	2,0
ST3,5	2,7
ST3,9	3,4
ST4,2	4,4
ST4,8	6,3
ST5,5	10,0
ST6,3	13,6
ST8	30,5
ST9,5	68,0

**iTeh STANDARD PREVIEW**  
**(standards.iteh.ai)**

[ISO 2702:2011](https://standards.iteh.ai/catalog/standards/sist/f6c80fc4-6ea3-4620-809d-d4ac55ab9488/iso-2702-2011)

<https://standards.iteh.ai/catalog/standards/sist/f6c80fc4-6ea3-4620-809d-d4ac55ab9488/iso-2702-2011>