Slotted set screws with flat point

Vis sans tête fendues à bout plat

iTeh Standards
(<https://standards.iteh.ai>)
Document Preview

[ISO 4766:2011](https://standards.iteh.ai/catalog/standards/iso/e83a9dcd-79eb-4ea3-a22f-2e4eb5496d0a/iso-4766-2011)

<https://standards.iteh.ai/catalog/standards/iso/e83a9dcd-79eb-4ea3-a22f-2e4eb5496d0a/iso-4766-2011>



iTeh Standards
(<https://standards.iteh.ai>)
Document Preview

[ISO 4766:2011](https://standards.iteh.ai/catalog/standards/iso/e83a9dcd-79eb-4ea3-a22f-2e4eb5496d0a/iso-4766-2011)

<https://standards.iteh.ai/catalog/standards/iso/e83a9dcd-79eb-4ea3-a22f-2e4eb5496d0a/iso-4766-2011>



COPYRIGHT PROTECTED DOCUMENT

© ISO 2011

All rights reserved. Unless otherwise specified, no part of this publication may be reproduced or utilized in any form or by any means, electronic or mechanical, including photocopying and microfilm, without permission in writing from either ISO at the address below or ISO's member body in the country of the requester.

ISO copyright office
Case postale 56 • CH-1211 Geneva 20
Tel. + 41 22 749 01 11
Fax + 41 22 749 09 47
E-mail copyright@iso.org
Web www.iso.org

Published in Switzerland

Foreword

ISO (the International Organization for Standardization) is a worldwide federation of national standards bodies (ISO member bodies). The work of preparing International Standards is normally carried out through ISO technical committees. Each member body interested in a subject for which a technical committee has been established has the right to be represented on that committee. International organizations, governmental and non-governmental, in liaison with ISO, also take part in the work. ISO collaborates closely with the International Electrotechnical Commission (IEC) on all matters of electrotechnical standardization.

International Standards are drafted in accordance with the rules given in the ISO/IEC Directives, Part 2.

The main task of technical committees is to prepare International Standards. Draft International Standards adopted by the technical committees are circulated to the member bodies for voting. Publication as an International Standard requires approval by at least 75 % of the member bodies casting a vote.

Attention is drawn to the possibility that some of the elements of this document may be the subject of patent rights. ISO shall not be held responsible for identifying any or all such patent rights.

ISO 4766 was prepared by Technical Committee ISO/TC 2, *Fasteners*, Subcommittee SC 11, *Fasteners with metric external thread*.

This second edition cancels and replaces the first edition (ISO 4766:1983), which has been technically revised.

iTeh Standards
(<https://standards.iteh.ai>)
Document Preview

[ISO 4766:2011](https://standards.iteh.ai/catalog/standards/iso/e83a9dcd-79eb-4ea3-a22f-2e4eb5496d0a/iso-4766-2011)

<https://standards.iteh.ai/catalog/standards/iso/e83a9dcd-79eb-4ea3-a22f-2e4eb5496d0a/iso-4766-2011>

Slotted set screws with flat point

1 Scope

This International Standard specifies the characteristics of slotted set screws with flat point and thread sizes from M1,2 to M12 inclusive and product grade A.

If other specifications are required, they can be selected from existing International Standards, for example ISO 261, ISO 888, ISO 898-5, ISO 965-2, ISO 3506-3, ISO 4759-1.

2 Normative references

The following referenced documents are indispensable for the application of this document. For dated references, only the edition cited applies. For undated references, the latest edition of the referenced document (including any amendments) applies.

ISO 225, *Fasteners — Bolts, screws, studs and nuts — Symbols and descriptions of dimensions*

ISO 261, *ISO general purpose metric screw threads — General plan*

ISO 898-5, *Mechanical properties of fasteners made of carbon steel and alloy steel — Part 5: Set screws and similar threaded fasteners with specified hardness classes — Coarse thread and fine pitch thread*

ISO 965-2, *ISO general purpose metric screw threads — Tolerances — Part 2: Limits of sizes for general purpose external and internal screw threads — Medium quality*

ISO 965-3, *ISO general purpose metric screw threads — Tolerances — Part 3: Deviations for constructional screw threads*

ISO 3269, *Fasteners — Acceptance inspection*

ISO 3506-3, *Mechanical properties of corrosion-resistant stainless steel fasteners — Part 3: Set screws and similar fasteners not under tensile stress*

ISO 4042, *Fasteners — Electroplated coatings*

ISO 4759-1, *Tolerances for fasteners — Part 1: Bolts, screws, studs and nuts — Product grades A, B and C*

ISO 6157-1, *Fasteners — Surface discontinuities — Part 1: Bolts, screws and studs for general requirements*

ISO 8839, *Mechanical properties of fasteners — Bolts, screws, studs and nuts made of non-ferrous metals*

ISO 8992, *Fasteners — General requirements for bolts, screws, studs and nuts*

ISO 10683, *Fasteners — Non-electrolytically applied zinc flake coatings*

ISO 16048, *Passivation of corrosion-resistant stainless-steel fasteners*

3 Dimensions

See Figure 1 and Table 1.

Symbols and descriptions of dimensions are specified in ISO 225.

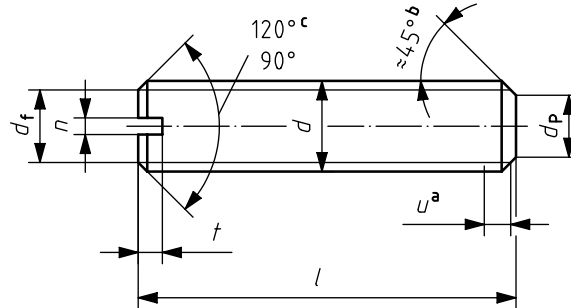

- a Incomplete thread $u \leq 2P$.
- b The 45° angle applies only to the portion of the point below the root diameter of the thread.
- c The 120° angle is mandatory for short length screws above the dotted stepped line.

Figure 1 — Slotted set screw with flat point

iTeh Standards
(<https://standards.iteh.ai>)
Document Preview

[ISO 4766:2011](https://standards.iteh.ai/catalog/standards/iso/e83a9dcd-79eb-4ea3-a22f-2e4eb5496d0a/iso-4766-2011)

<https://standards.iteh.ai/catalog/standards/iso/e83a9dcd-79eb-4ea3-a22f-2e4eb5496d0a/iso-4766-2011>