Hexagon washer head tapping screws

Vis à tôle à tête hexagonale à embase plate

iTeh STANDARD PREVIEW
(standards.iteh.ai)

[ISO 7053:2011](https://standards.iteh.ai/catalog/standards/sist/cd948770-611d-4f1d-83ee-6c6db9dc6810/iso-7053-2011)

<https://standards.iteh.ai/catalog/standards/sist/cd948770-611d-4f1d-83ee-6c6db9dc6810/iso-7053-2011>



iTeh STANDARD PREVIEW
(standards.iteh.ai)

ISO 7053:2011

<https://standards.iteh.ai/catalog/standards/sist/cd948770-611d-4f1d-83ee-6c6db9dc6810/iso-7053-2011>



COPYRIGHT PROTECTED DOCUMENT

© ISO 2011

All rights reserved. Unless otherwise specified, no part of this publication may be reproduced or utilized in any form or by any means, electronic or mechanical, including photocopying and microfilm, without permission in writing from either ISO at the address below or ISO's member body in the country of the requester.

ISO copyright office
Case postale 56 • CH-1211 Geneva 20
Tel. + 41 22 749 01 11
Fax + 41 22 749 09 47
E-mail copyright@iso.org
Web www.iso.org

Published in Switzerland

Foreword

ISO (the International Organization for Standardization) is a worldwide federation of national standards bodies (ISO member bodies). The work of preparing International Standards is normally carried out through ISO technical committees. Each member body interested in a subject for which a technical committee has been established has the right to be represented on that committee. International organizations, governmental and non-governmental, in liaison with ISO, also take part in the work. ISO collaborates closely with the International Electrotechnical Commission (IEC) on all matters of electrotechnical standardization.

International Standards are drafted in accordance with the rules given in the ISO/IEC Directives, Part 2.

The main task of technical committees is to prepare International Standards. Draft International Standards adopted by the technical committees are circulated to the member bodies for voting. Publication as an International Standard requires approval by at least 75 % of the member bodies casting a vote.

Attention is drawn to the possibility that some of the elements of this document may be the subject of patent rights. ISO shall not be held responsible for identifying any or all such patent rights.

ISO 7053 was prepared by Technical Committee ISO/TC 2, *Fasteners*, Subcommittee SC 13, *Fasteners with non-metric thread*.

This second edition cancels and replaces the first edition (ISO 7053:1992), which has been technically revised.

iTeh STANDARD PREVIEW
(standards.iteh.ai)

[ISO 7053:2011](https://standards.iteh.ai/catalog/standards/sist/cd948770-611d-4f1d-83ee-6c6db9dc6810/iso-7053-2011)

<https://standards.iteh.ai/catalog/standards/sist/cd948770-611d-4f1d-83ee-6c6db9dc6810/iso-7053-2011>

iTeh STANDARD PREVIEW
(standards.iteh.ai)

ISO 7053:2011

<https://standards.iteh.ai/catalog/standards/sist/cd948770-611d-4f1d-83ee-6c6db9dc6810/iso-7053-2011>

Hexagon washer head tapping screws

1 Scope

This International Standard specifies hexagon washer head tapping screws with thread sizes from ST 2,2 to ST 8 inclusive.

2 Normative references

The following referenced documents are indispensable for the application of this document. For dated references, only the edition cited applies. For undated references, the latest edition of the referenced document (including any amendments) applies.

ISO 225, *Fasteners — Bolts, screws, studs and nuts — Symbols and descriptions of dimensions*

ISO 1478, *Tapping screws thread*

ISO 2702, *Heat-treated steel tapping screws — Mechanical properties*

ISO 3269, *Fasteners — Acceptance inspection*

ISO 3506-4, *Mechanical properties of corrosion-resistant stainless steel fasteners — Part 4: Tapping screws*

ISO 4042, *Fasteners — Electroplated coatings*

ISO 4759-1, *Tolerances for fasteners — Part 1: Bolts, screws, studs and nuts — Product grades A, B and C*

ISO 8992, *Fasteners — General requirements for bolts, screws, studs and nuts*

ISO 10683, *Fasteners — Non-electrolytically applied zinc flake coatings*

ISO 16048, *Passivation of corrosion-resistant stainless-steel fasteners*

3 Dimensions

See Figure 1 and Table 1.

Symbols and descriptions of dimensions are specified in ISO 225.

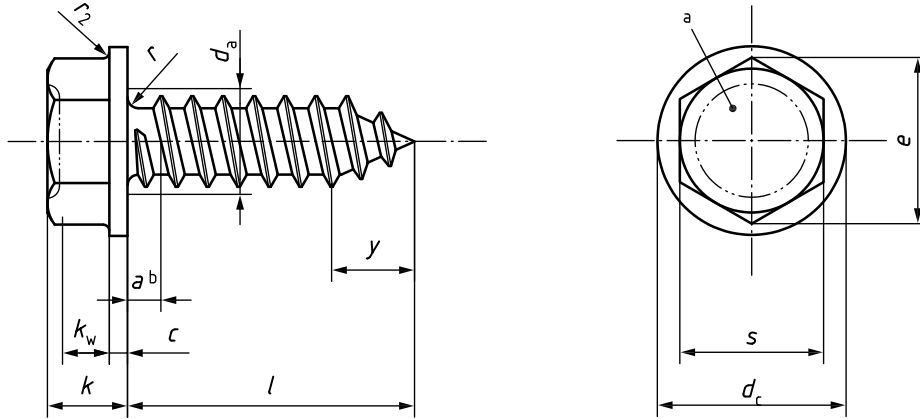

a) Type C

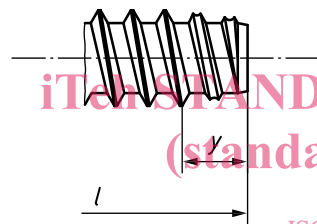

iteh STANDARD PREVIEW
(standards.iteh.ai)
ISO 7053:2011
<https://standards.iteh.ai/catalog/standards/sist/cd948770-611d-4f1d-83ee-6c6db9dc6810/iso-7053-2011>

b) Type F

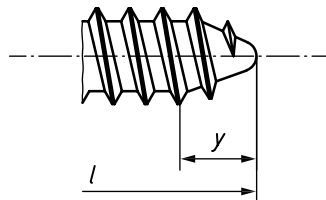

c) Type R

- a Optional indentation.
- b Dimension a shall be measured at the core diameter of the first full thread.

Figure 1 — Hexagon washer head tapping screws

Table 1 — Dimensions

Dimensions in millimetres

Thread		ST 2,2	ST 2,9	ST 3,5	ST 3,9	ST 4,2	ST 4,8	ST 5,5	ST 6,3	ST 8				
p^a		0,8	1,1	1,3	1,3	1,4	1,6	1,8	1,8	2,1				
a	max.	0,8	1,1	1,3	1,3	1,4	1,6	1,8	1,8	2,1				
c	min.	0,25	0,40	0,60	0,60	0,80	0,90	1,00	1,00	1,20				
d_a	max.	2,8	3,5	4,1	4,6	4,9	5,6	6,3	7,3	9,2				
d_c	max.	4,2	6,3	8,3	8,3	8,8	10,5	11,0	13,5	18,0				
	min.	3,8	5,8	7,6	7,6	8,1	9,8	10,0	12,2	16,7				
s	nom. = max.	3,00	4,00	5,50	5,50	7,00	8,00	8,00	10,00	13,00				
	min.	2,86	3,82	5,32	5,32	6,78	7,78	7,78	9,78	12,73				
e	min.	3,20	4,28	5,96	5,96	7,59	8,71	8,71	10,95	14,26				
k	nom. = max.	2,0	2,8	3,4	3,4	4,1	4,3	5,4	5,9	7,0				
	min.	1,7	2,5	3,0	3,0	3,6	3,8	4,8	5,3	6,4				
k_w	min.	0,9	1,3	1,5	1,5	1,8	2,2	2,7	3,1	3,3				
r	min.	0,3	0,4	0,5	0,5	0,6	0,7	0,8	0,9	1,1				
r_2	max.	0,15	0,20	0,25	0,25	0,30	0,30	0,40	0,50	0,60				
y	Type C	2,0	2,6	3,2	3,5	3,7	4,3	5,0	6,0	7,5				
	Type F	1,6	2,1	2,5	2,7	2,8	3,2	3,6	3,6	4,2				
	Type R	2,7	3,0	3,2	3,0	3,2	3,6	4,3	5,0	6,3				
l^b					ISO 7053:2011 Approximate mass, in kilograms per 1 000 pieces ($\rho = 7,85 \text{ kg/dm}^3$) (for information only)									
nom.	Type C and Type R		Type F											
	min.	max.	min.	max.										
4,5	3,7	5,3	3,7	4,5	0,17	—	—	—	—	—	—	—	—	—
6,5	5,7	7,3	5,7	6,5	0,21	0,43	0,93	—	—	—	—	—	—	—
9,5	8,7	10,3	8,7	9,5	0,27	0,54	1,10	1,14	1,84	2,48	—	—	—	—
13	12,2	13,8	12,2	13,0	0,35	0,66	1,28	1,35	2,09	2,80	3,64	5,44	—	—
16	15,2	16,8	15,2	16,0	0,41	0,77	1,44	1,54	2,31	3,10	4,01	5,96	10,90	—
19	18,2	19,8	18,2	19,0	0,47	0,87	1,59	1,73	2,52	3,39	4,40	6,49	11,80	—
22	21,2	22,8	20,7	22,0	—	—	1,74	1,93	2,74	3,68	4,78	7,01	12,70	—
25	24,2	25,8	23,7	25,0	—	—	—	2,12	2,95	3,97	5,17	7,54	13,60	—
32	30,7	33,3	30,7	32,0	—	—	—	—	—	4,66	6,06	8,76	15,70	—
38	36,7	39,3	36,7	38,0	—	—	—	—	—	—	6,82	9,82	17,50	—
45	43,7	46,3	43,5	45,0	—	—	—	—	—	—	—	11,10	19,60	—
50	48,7	51,3	48,5	50,0	—	—	—	—	—	—	—	12,00	21,10	—
NOTE Preferred lengths are those between the continuous, bold, stepped lines.														
^a P = pitch of the thread.														
^b Sizes with lengths marked with a dash (—) cannot be manufactured.														

4 Specifications and reference International Standards

See Table 2.

Table 2 — Specifications and reference International Standards

Material	Steel, in accordance with ISO 2702	Stainless steel
General requirements	ISO 8992	
Thread	ISO 1478	
Mechanical property	Steel grade/ hardness class	—
	International Standard	ISO 2702
Tolerances	Product grade	A
	International Standard	ISO 4759-1
Finish — Coating	As processed	
	Requirements for electroplating are specified in ISO 4042. Requirements for non-electrolytically applied zinc flake coatings are specified in ISO 10683. Additional requirements or other finishes or coatings shall be agreed between the supplier and the purchaser.	Requirements for passivation are specified in ISO 16048.
Acceptability	Acceptance inspection is specified ISO 3269.	

5 Designation

EXAMPLE 1 A hexagon washer head tapping screw with thread size ST 3,5, nominal length $l = 16$ mm, made of steel (St) in accordance with ISO 2702 and rounded end (Type R) is designated as follows:

Tapping screw ISO 7053 - ST 3,5 × 16 - St - R

EXAMPLE 2 Designation of a hexagon washer head tapping screw with thread size ST 3,5, nominal length $l = 16$ mm, made of stainless steel (A4-20H) in accordance with ISO 3506-4 and rounded end (Type R) is designated as follows:

Tapping screw ISO 7053 - ST 3,5 × 16 - A4-20H - R

iTeh STANDARD PREVIEW
(standards.iteh.ai)

ISO 7053:2011

<https://standards.iteh.ai/catalog/standards/sist/cd948770-611d-4f1d-83ee-6c6db9dc6810/iso-7053-2011>