



SLOVENSKI STANDARD
SIST EN 13586:2004

01-september-2004

Dvigala - Dostop

Cranes - Access

Krane - Zugang

Appareils de levage a charge suspendue - Acces

iTeh STANDARD PREVIEW
(standards.itteh.ai)

Ta slovenski standard je istoveten z: EN 13586:2004

SIST EN 13586:2004
<https://standards.itteh.ai/catalog/standards/sist/bc1da5b9-7874-4ffc-ae77-1d358b24fb7b/sist-en-13586-2004>

ICS:

53.020.20 Dvigala

Cranes

SIST EN 13586:2004

en

iTeh STANDARD PREVIEW
(standards.iteh.ai)

[SIST EN 13586:2004](#)

<https://standards.iteh.ai/catalog/standards/sist/bcfda3b9-7874-4ffe-ae77-1d358b24fb7b/sist-en-13586-2004>

EUROPEAN STANDARD
NORME EUROPÉENNE
EUROPÄISCHE NORM

EN 13586

June 2004

ICS 53.020.20

English version

Cranes - Access

Appareils de levage à charge suspendue - Accès

Krane - Zugang

This European Standard was approved by CEN on 1 October 2003.

CEN members are bound to comply with the CEN/CENELEC Internal Regulations which stipulate the conditions for giving this European Standard the status of a national standard without any alteration. Up-to-date lists and bibliographical references concerning such national standards may be obtained on application to the Central Secretariat or to any CEN member.

This European Standard exists in three official versions (English, French, German). A version in any other language made by translation under the responsibility of a CEN member into its own language and notified to the Central Secretariat has the same status as the official versions.

CEN members are the national standards bodies of Austria, Belgium, Cyprus, Czech Republic, Denmark, Estonia, Finland, France, Germany, Greece, Hungary, Iceland, Ireland, Italy, Latvia, Lithuania, Luxembourg, Malta, Netherlands, Norway, Poland, Portugal, Slovakia, Slovenia, Spain, Sweden, Switzerland and United Kingdom.

(standards.iteh.ai)

SIST EN 13586:2004

<https://standards.iteh.ai/catalog/standards/sist/bcfd3b9-7874-4ff6-ae77-1d358b24fb7b/sist-en-13586-2004>



EUROPEAN COMMITTEE FOR STANDARDIZATION
COMITÉ EUROPÉEN DE NORMALISATION
EUROPÄISCHES KOMITEE FÜR NORMUNG

Management Centre: rue de Stassart, 36 B-1050 Brussels

Contents

Foreword.....	3
Introduction	4
1 Scope	5
2 Normative references	5
3 Terms, definitions and symbols	6
3.1 Symbols	6
3.2 Terms and definitions	7
4 List of significant hazards	7
5 Classification of access	9
6 Safety requirements and / or protective measures	9
6.1 Selection of access	9
6.2 General.....	11
6.3 Stairs and stepped ladders	12
6.4 Rung ladders - footholds	13
6.5 Hoop guards.....	17
6.6 Walkways, inclined walkways, platforms, and manholes	19
6.7 Handholds, handrails, intermediate guard rails and side protection.....	21
6.8 Minimum free space for walkway and inclined walkway.....	24
6.9 Hatch	24
6.10 Strength	24
7 Verification of the safety requirements and/or protective measures	24
8 Information for use	26
Annex A (informative) List of existing design rules for cranes	27
Annex ZA (informative) Relationship of this document with EC Directives.....	29

Foreword

This document EN 13586:2004 has been prepared by WG 4 under the direction of Technical Committee CEN/TC 147, "Cranes - Safety", the secretariat of which is held by BSI.

This European Standard shall be given the status of a national standard, either by publication of an identical text or by endorsement, at the latest by December 2004, and conflicting national standards shall be withdrawn at the latest by December 2004.

This document has been prepared under a mandate given to CEN by the European Commission and the European Free Trade Association and supports essential requirements of EC Directive(s).

For relationship with EC Directives, see informative annex ZA, which is an integral part of this document.

Annexes A and B are informative.

According to the CEN/CENELEC Internal Regulations, the national standards organizations of the following countries are bound to implement this European Standard: Austria, Belgium, Cyprus, Czech Republic, Denmark, Estonia, Finland, France, Germany, Greece, Hungary, Iceland, Ireland, Italy, Latvia, Lithuania, Luxembourg, Malta, Netherlands, Norway, Poland, Portugal, Slovakia, Slovenia, Spain, Sweden, Switzerland and United Kingdom

iTeh STANDARD PREVIEW
(standards.iteh.ai)

[SIST EN 13586:2004](https://standards.iteh.ai/catalog/standards/sist/bcfda3b9-7874-4ffe-ae77-1d358b24fb7b/sist-en-13586-2004)

<https://standards.iteh.ai/catalog/standards/sist/bcfda3b9-7874-4ffe-ae77-1d358b24fb7b/sist-en-13586-2004>

EN 13586:2004 (E)

Introduction

This European Standard is a harmonised standard to provide one means for access on cranes to conform with the relevant Essential Health and Safety Requirements of the Machinery Directive 98/37/EC.

This European Standard is a type C standard as stated in EN 1070.

The machinery concerned and the extent to which hazards, hazardous situations and events are covered are indicated in the scope of this standard.

When provisions of this type C standard are different from those which are stated in type B standard, the provisions of this type C standard take precedence over the provisions of the other standards, for machines that have been designed and built according to the provisions of this type C standard.

iTeh STANDARD PREVIEW (standards.iteh.ai)

[SIST EN 13586:2004](#)

<https://standards.iteh.ai/catalog/standards/sist/bcfda3b9-7874-4ffe-ae77-1d358b24fb7b/sist-en-13586-2004>

1 Scope

This European Standard specifies design requirements for non-powered access installed on cranes.

NOTE 1 For other type of access a requirement for information to be supplied is specified.

This European Standard covers access to control stations and all access required for maintenance, certain erection and dismantling operations (see below) and emergency.

For those cranes which are intended to be erected and dismantled at their places of work, specific requirements for the access needed during these operations are given in the appropriate European Standards for specific crane types.

NOTE 2 Specific requirements for access on particular types of crane are given in the appropriate European Standard for the particular crane type.

The dimensions given in this European Standard do not take into account the safety distances related to:

- guarding;
- relative movement between crane and adjacent structure;
- hazardous surface temperature;
- electrical equipment.

The significant hazards covered by this European Standard are identified in clause 4.

This European Standard is not applicable to cranes which are manufactured before the date of publication by CEN of this standard.

[SIST EN 13586:2004](https://standards.iteh.ai/catalog/standards/sist/bc1da3b9-7874-4ffe-ae77-1d358b24fb7b/sist-en-13586-2004)

<https://standards.iteh.ai/catalog/standards/sist/bc1da3b9-7874-4ffe-ae77-1d358b24fb7b/sist-en-13586-2004>

2 Normative references

This European Standard incorporates by dated or undated reference, provisions from other publications. These normative references are cited at the appropriate places in the text, and the publications are listed hereafter. For dated references, subsequent amendments to or revisions of any of these publications apply to this European Standard only when incorporated in it by amendment or revision. For undated references the latest edition of the publication referred to applies (including amendments).

EN 292-1:1991, *Safety of machinery - Basic concepts, general principles for design — Part 1: Basic terminology, methodology.*

EN 292-2:1991 + A1: 1995, *Safety of machinery — Basic concepts, general principles for design — Part 2: Technical principles and specifications.*

EN 349, *Safety of machinery — Minimum gaps to avoid crushing of parts of the human body.*

EN 363, *Personal protective equipment against falls from a height — Fall arrest systems.*

EN 1070:1998, *Safety of machinery — Terminology.*

EN 13586:2004 (E)

3 Terms, definitions and symbols**3.1 Symbols**

b	Rung end
d	Distance between centre line of rung and vertical surface
e	Distance between the ladder and an obstacle to the rear
f	Distance between the axis of the ladder and a lateral obstacle
g	Going
g	Gap between stiles if they are discontinuous
g	Gap between separate sections of handrails when they are discontinuous
h	Rise
i	Rung pitch
k	Rung size
l	Clear width
m	Clear width
n	Diameter, width, thickness
p	Tread width
p	Free length for hand-clearance
q	Hand clearance to mounting surface
r	Vertical distance between the lower part of handrails and handholds and the floor or the foothold
s	Vertical distance between the higher part of the handrail and the floor of the platform or rest platform situated at the top of the ladder or the stair
t	Handrail situated along a ladder. Clearance between the edge of the handrail and the edge of the rung or the side rail of the ladder
u	Clearance between parallel handrails where the body has to pass through
v	Distance between the floor or stair and the handrail or guard-rail
v1	Gap between the top of the toe board and the bottom of the intermediate guard rail
v2	Gap between the top of the intermediate guard rail and the bottom of the guard-rail
w	Distance between the floor and the top of the toe board
y	Clearance between the floor and the lower edge of the toe board
z	Distance between rungs and handhold or handrails

iTeh STANDARD PREVIEW
(standards.iteh.ai)

[SIST EN 13586:2004](https://standards.iteh.ai/catalog/standards/sist/bc1da3b9-7874-4ffe-ae77-1d358b24fb7b/sist-en-13586-2004)

<https://standards.iteh.ai/catalog/standards/sist/bc1da3b9-7874-4ffe-ae77-1d358b24fb7b/sist-en-13586-2004>

A	Width of walkways, inclined walkways
B x C	Free length / width of rest platforms
D x E	Free length / width of platforms
F	Manhole effective aperture - Side of a square section or diameter of a round section
H x W	Manhole effective aperture - Rectangular section (height x width)
K	Free height above the floor of walkways, inclined walkways: person in kneeling posture
U	Free height above the floor of walkways, inclined walkways: person moving upright
U	Free height above the floor of the platforms
L	Manhole effective aperture - Length of passage through the manhole

3.2 Terms and definitions

For the purposes of this European Standard the terms and definitions given in EN 1070:1998 and the following apply.

3.2.1

rest platform

standing area for persons to rest, situated at intervals between flights of ladders or stairs

3.2.2

platform

standing area for persons to work from e.g. for maintenance or inspection

3.2.3

handrail

device, which provides continuous hand support between two locations

3.2.4

handhold

means of providing support by a single hand placement

3.2.5

foothold

means of providing support for one or two feet

3.2.6

manhole

access opening to allow the passage of a person and which could have a cover fitted

3.2.7

hatch

access opening to allow the passage of a person and which has a hinged door fitted

4 List of significant hazards

Table 1 contains all the significant hazards, hazardous situations and events, as far as they are dealt with in this standard, identified by risk assessment as significant for this type of machinery and which require action to eliminate or reduce the risk.

Table 1 — List of significant hazards and associated requirements

N°	Hazards	EN 292 Part 1 : 1991	EN 292 Part 2 : 1991	Annex A of EN 292-2:1991 A1 : 1995	Relevant clause(s) in this standard
1	Mechanical hazards				
1.1	Generated by machine parts of work pieces caused, for example, by	4.2	3.1, 3.2, 4	1.3	
1.1.1	Shape				6.2.6, 6.4
1.1.5	Inadequacy of mechanical strength				6.2.3b, 6.5.2, 6.10
1.3	Elementary forms of mechanical hazards	4.2.1		1.3	
1.3.3	Cutting or severing hazard				6.2.6
7	Hazards generated by materials and substances processed, used by the machinery and by its constituent materials				
7.2	Fire hazard	4.8	3.4	1.5.6, 1.5.7	6.2.3c
8	Hazards generated by neglecting ergonomic principles in machinery design as, e.g. hazards from				
8.1	Unhealthy postures or excessive effort	4.9	3.6.1, 6.2.1, 6.2.3, 6.2.4, 6.2.6	1.1.2d, 1.1.5, 1.6.2, 1.6.4	6.1, 6.2.1, 6.2.2, 6.2.3a, 6.3, 6.4, 6.5, 6.6, 6.7, 6.8
8.2	Inadequate consideration of hand-arm or foot-leg anatomy	4.9	3.6.2	1.1.2d, 2.2	6.2.2, 6.3, 6.4, 6.7
8.3	Neglected use of personal protection equipment		3.6.6	1.1.2e	5, 6.6, 6.3, 6.4
17	Falling or ejected objects or fluids	4.2.2	3.3, 3.8	1.3.3	6.2.5, 6.7
19	Slip, trip and fall of persons (related to machinery)	4.2.3	6.2.4	1.5.15	6.2.3c, 6.6, 6.7
21	Linked to the work position (including driving station) on the machine				
21.1	Fall of persons during access to (or at/from) the work position			3.2.1, 3.2.3, 3.4.5, 3.4.7	6.2.1, 6.2.2, 6.2.3c, 6.2.6, 6.2.7, 6.3, 6.4, 6.5, 6.6, 6.7
21.10	Insufficient means for evacuation/emergency exit			3.2.1	6.2.4

5 Classification of access

For the purposes of this standard, the following cases apply:

- a) Type 1 Access: Access designed for use without personal protective equipment against falls from a height;
- b) Type 2 Access: Access for which some characteristics of type 1 access are not respected and the use of which may require a personal protective equipment against falls from a height (see EN 363).

NOTE For the design of personal protective equipment anchorage, see EN 795.

6 Safety requirements and / or protective measures

6.1 Selection of access

6.1.1 Selection of the means of access

Means of access shall conform to the safety requirements and / or protective measures of this clause. In addition, the equipment shall be designed according to the principles of EN 292 for hazards relevant but not significant which are not dealt with by this standard.

Manufacturers shall take into consideration the following when determining the means of access to be provided:

- a) frequency of use;
- b) equipment or tools to be carried;
- c) vertical distance to cover;
- d) nature of use e.g. maintenance, inspection, walkway.

iTeh STANDARD PREVIEW

(standards.iteh.ai)

[SIST EN 13586:2004](#)

[https://standards.iteh.ai/catalog/standards/sist/bc1da3b9-7874-4ffe-ac77-](https://standards.iteh.ai/catalog/standards/sist/bc1da3b9-7874-4ffe-ac77-1d558624b7b/sist-en-13586-2004)

[1d558624b7b/sist-en-13586-2004](#)

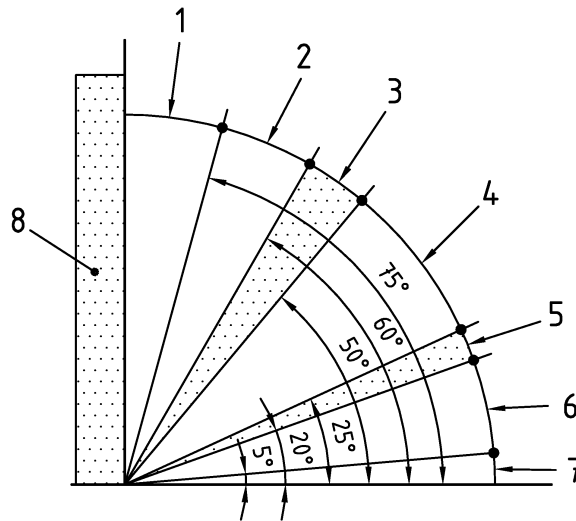
**Key**

- 1 Rung ladder
- 2 Stepped ladder
- 3 should be avoided
- 4 Stairs
- 5 should be avoided
- 6 inclined walkway
- 7 walkway
- 8 Not permitted zone

iTeh STANDARD PREVIEW (standards.iteh.ai)

[SIST EN 13586:2004](https://standards.iteh.ai/catalog/standards/sist/bcfd3b9-7874-4ffe-ae77-1d358b24fb7b/sist-en-13586-2004)

<https://standards.iteh.ai/catalog/standards/sist/bcfd3b9-7874-4ffe-ae77-1d358b24fb7b/sist-en-13586-2004>

Figure 1 — Ranges of angle for different means of access in their working position

Provision of access should be in the preferential order: stair, rung ladder stepped ladder. Furthermore fixed means (e.g. hoop guard, side protection) shall be preferred to personnel protective equipment.

When the height that the operator has to climb from the point of access on the crane to the control station is more than 25 m, a powered access system should be provided. If a powered access system is provided, the crane shall be designed to receive it. In this case, a complementary mean of access of type 1 shall also be provided.

6.1.2 Selection of the type of access

The selection of the type of access shall be as follows:

- access to control station and starting equipment: **type 1 access**;
- access for maintenance period more frequent than one per month : **type 1 access**;

In the following cases **type 2 access** may be used:

- access for maintenance period less frequent than one per month. In this case, the access shall be designed for use without personal protective device against the falls from height;
- access for erection and dismantling