**Welding consumables — Determination
of moisture resistance of manual metal
arc welding electrodes by measurement
of diffusible hydrogen**

*Produits consommables pour le soudage — Détermination de la reprise
d'humidité des électrodes utilisées en soudage manuel à l'arc avec
électrode enrobée, par mesurage de l'hydrogène diffusible*

iTeh STANDARD PREVIEW
(standards.iteh.ai)

ISO 14372:2011

<https://standards.iteh.ai/catalog/standards/sist/b75dbcf3-dca5-467d-9f0c-55f7a086d263/iso-14372-2011>



iTeh STANDARD PREVIEW
(standards.iteh.ai)

ISO 14372:2011

<https://standards.iteh.ai/catalog/standards/sist/b75dbcf3-dca5-467d-9f0c-55f7a086d263/iso-14372-2011>



COPYRIGHT PROTECTED DOCUMENT

© ISO 2011

All rights reserved. Unless otherwise specified, no part of this publication may be reproduced or utilized in any form or by any means, electronic or mechanical, including photocopying and microfilm, without permission in writing from either ISO at the address below or ISO's member body in the country of the requester.

ISO copyright office
Case postale 56 • CH-1211 Geneva 20
Tel. + 41 22 749 01 11
Fax + 41 22 749 09 47
E-mail copyright@iso.org
Web www.iso.org

Published in Switzerland

Foreword

ISO (the International Organization for Standardization) is a worldwide federation of national standards bodies (ISO member bodies). The work of preparing International Standards is normally carried out through ISO technical committees. Each member body interested in a subject for which a technical committee has been established has the right to be represented on that committee. International organizations, governmental and non-governmental, in liaison with ISO, also take part in the work. ISO collaborates closely with the International Electrotechnical Commission (IEC) on all matters of electrotechnical standardization.

International Standards are drafted in accordance with the rules given in the ISO/IEC Directives, Part 2.

The main task of technical committees is to prepare International Standards. Draft International Standards adopted by the technical committees are circulated to the member bodies for voting. Publication as an International Standard requires approval by at least 75 % of the member bodies casting a vote.

Attention is drawn to the possibility that some of the elements of this document may be the subject of patent rights. ISO shall not be held responsible for identifying any or all such patent rights.

ISO 14372 was prepared by the International Institute of Welding, recognized as an international standardizing body in the field of welding in accordance with Council Resolution 42/1999.

This second edition cancels and replaces the first edition (ISO 14372:2000), which has been technically revised.

Requests for official interpretations of any aspect of this International Standard should be directed to the ISO Central Secretariat, who will forward them to the IIW Secretariat for an official response.

<https://standards.iteh.ai/catalog/standards/sist/b75dbcf3-dca5-467d-9f0c-55f7a086d263/iso-14372-2011>

Introduction

This test method is based on procedures originally put forward within Sub-commission II-A of the International Institute of Welding (IIW) by the delegation from Argentina. It was subsequently evaluated in a round robin exercise within IIW Sub-commission II-A, and served as the basis for ISO 14372:2000. This International Standard was developed with Sub-commissions II-A and II-E of the International Institute of Welding (IIW).

iTeh STANDARD PREVIEW (standards.iteh.ai)

[ISO 14372:2011](https://standards.iteh.ai/catalog/standards/sist/b75dbcf3-dca5-467d-9f0c-55f7a086d263/iso-14372-2011)

<https://standards.iteh.ai/catalog/standards/sist/b75dbcf3-dca5-467d-9f0c-55f7a086d263/iso-14372-2011>

Welding consumables — Determination of moisture resistance of manual metal arc welding electrodes by measurement of diffusible hydrogen

1 Scope

This International Standard specifies a method for the relative ranking, by 24 h exposure to humid air and subsequent diffusible hydrogen testing, of manual metal arc electrode coatings related to their tendency to absorb moisture. This test method has limited potential applicability since it is unlikely to be capable of being scaled up for large volumes of testing.

2 Normative references

The following referenced documents are indispensable for the application of this document. For dated references, only the edition cited applies. For undated references, the latest edition of the referenced document (including any amendments) applies.

ISO 3690, *Welding and allied processes — Determination of hydrogen content in arc weld metal*¹⁾

3 Principle

This procedure is presented as a standard method for exposure and control of welding consumables in preparation for, and during, diffusible hydrogen testing. After drying (if applicable), the electrodes are exposed to an air atmosphere of controlled temperature and humidity [27 °C, 80 % relative humidity²⁾ (RH)] by enclosing them in a box containing a saturated solution of ammonium sulfate.

4 Equipment

4.1 Humidity box, made of acrylic or similar inert material, consisting of a box within which test electrodes, a thermometer, and protecting tubes (maximum $\sim 1,5d$, where d is the overall diameter of the electrode, and appropriate length to fit) for holding the electrodes after exposure can be suspended over a saturated solution of ammonium sulfate (see Figure 1).

IMPORTANT — Any attempt to measure relative humidity, if used, shall not cause air circulation within the humidity box.

4.2 Temperature control cabinet, capable of being maintained at a temperature of $27\text{ °C} \pm 1\text{ °C}$. Good results have been achieved using a draught-proof enclosure heated by low-power (40 W) light bulbs, controlled by a calibrated thermostat, or by another suitable thermal source, with a fan for circulating air to maintain uniform air temperature.

1) To be published. (Revision of ISO 3690:2000.)

2) It is not necessary to measure relative humidity within the humidity box. The test conditions are the temperature and the presence of the saturated salt bath. Well-established physical principles relate the relative humidity to these two conditions.

Dimensions in millimetres

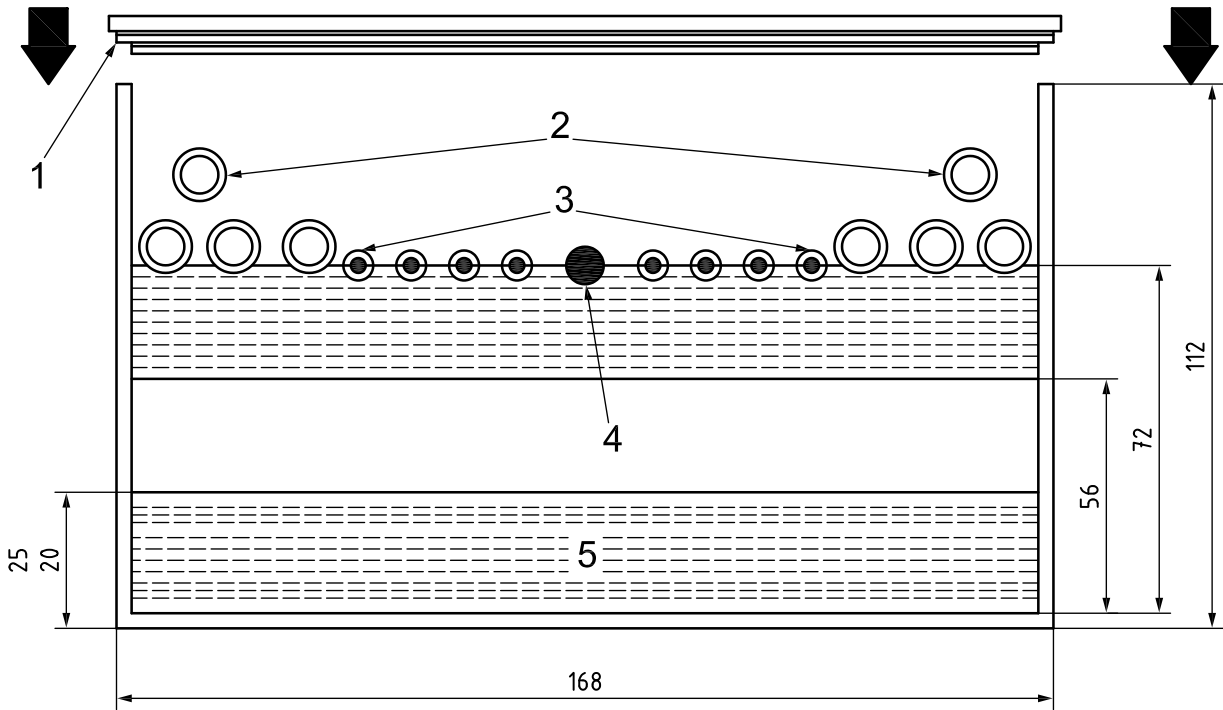

iTeh STANDARD PREVIEW
(standards.iteh.ai)

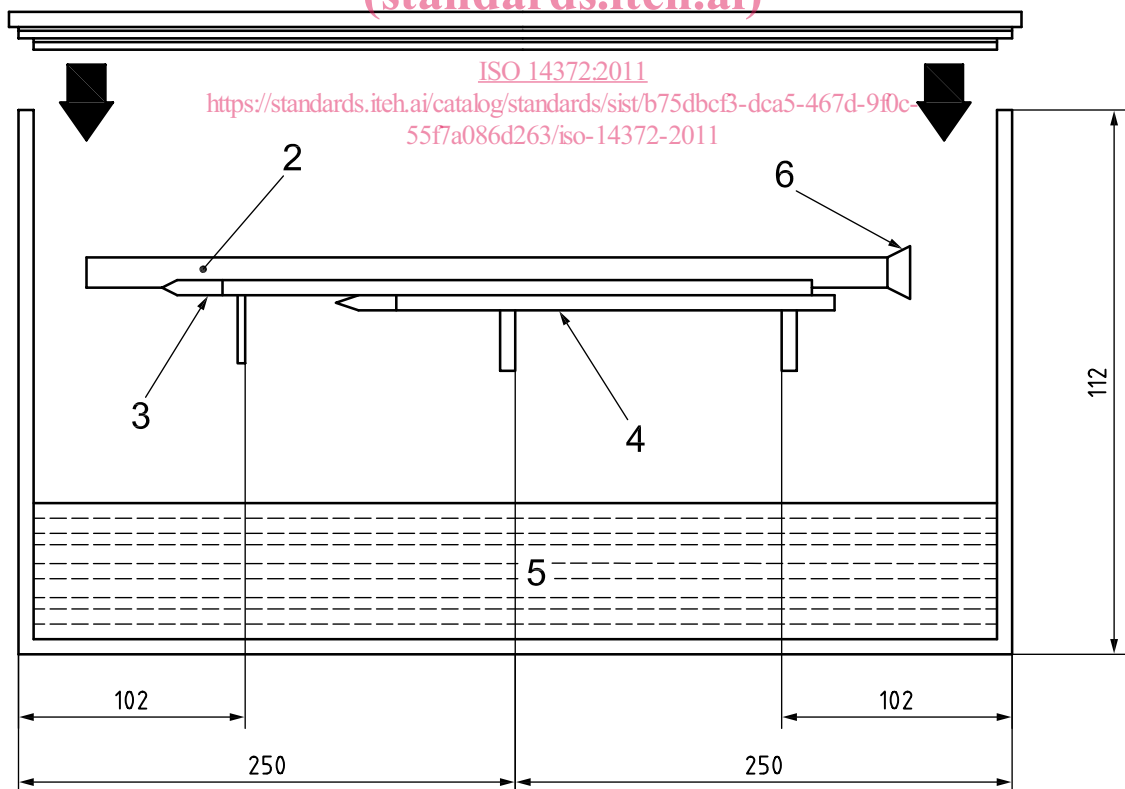

Key

- | | | | | | |
|---|------------------|---|-------------|---|-------------------------------------|
| 1 | packing | 3 | electrodes | 5 | saturated ammonium sulfate solution |
| 2 | protecting tubes | 4 | thermometer | 6 | plugs |

Figure 1 — Sketch of a humidity box

5 Procedure

5.1 Preparation of humidity box

5.1.1 Wash all tubes with distilled water.

5.1.2 Air dry tubes.

5.1.3 Seal one end of each tube with a plug.

5.1.4 Dissolve 1,3 kg anhydrous ammonium sulfate in 1 500 ml distilled water at 40 °C to 45 °C.

5.1.5 Fill the humidity box (4.1) with this solution (5.1.4) to a depth of 20 mm to 25 mm. If the height of solution drops, transfer solution to a mixing vessel, add further saturated solution or distilled water at 45 °C, mixing thoroughly. Refill the box to a depth of 25 mm, ensuring that undissolved ammonium sulfate is present, but does not reduce the surface area of the liquid when restored to the operating temperature of 27 °C.

5.1.6 A finger moistened with silicone oil may be run around the box just above solution level. (This helps prevent crystals creeping up the walls.)

5.1.7 Allow solution to cool to 27 °C ± 1 °C.

5.1.8 Insert protecting tubes, second end plugs (not fitted in tubes) and thermometer, and close lid on box.

5.2 Preparation of temperature control cabinet

5.2.1 Set the temperature to 27 °C ± 1 °C.

5.2.2 Hold the temperature at 27 °C ± 1 °C for at least 90 min.

5.3 Preconditioning of humidity box

Keep the prepared and sealed box in the temperature control cabinet for at least 4 h, with the temperature maintained at 27 °C ± 1 °C.

5.4 Electrode preparation

5.4.1 Mark coatings near the stub end with a unique identity.

5.4.2 Pre-dry (if appropriate) according to manufacturer's instructions.

5.4.3 If electrodes have been dried at elevated temperature, seal in glass tubes using tightly fitting rubber bungs or by melting the ends, or place in a desiccator to cool to room temperature.

5.5 Exposure of electrodes in humidity box

5.5.1 Open the temperature control cabinet (4.2) door.

5.5.2 Open humidity box lid.

5.5.3 Transfer electrodes from glass tubes, desiccator, or manufacturer's packaging, as appropriate, to the humidity box as indicated in Figure 1.

5.5.4 The procedures specified in 5.5.1 to 5.5.3 shall be completed within 90 s.

5.5.5 Replace humidity box lid.

5.5.6 Close temperature control cabinet door.

5.5.7 The procedures specified in 5.5.5 and 5.5.6 shall be completed within a further 30 s.

5.5.8 Expose electrodes at $27\text{ °C} \pm 1\text{ °C}$ for 24 h.

5.6 Measurement of weld deposit hydrogen

5.6.1 Open temperature control cabinet door.

5.6.2 Open humidity box lid.

5.6.3 Insert electrodes into protection tubes, seal ends with plugs, and remove from temperature control cabinet.

5.6.4 The procedures specified in 5.6.2 and 5.6.3 shall be completed within 60 s.

5.6.5 Close humidity box and temperature control cabinet door.

5.6.6 Transfer electrodes in sealed tubes to welding station.

Electrodes shall be welded within 24 h of removal from the humidity box.

5.6.7 Weld and analyse for hydrogen in accordance with ISO 3690.

Welding shall take place within 2 min of removal of electrodes from the sealed tubes.

5.6.8 Record ambient room temperature and relative humidity (RH) at the time of welding.

6 Test report

ISO 14372:2011
<https://standards.iteh.ai/catalog/standards/sist/b75dbcf3-dca5-467d-9f0c-55f7a086d263/iso-14372-2011>

The test report shall contain at least the following information:

- a) the weld deposit hydrogen levels, expressed in millilitres per 100 g deposited metal, as measured;
- b) a reference to this International Standard (ISO 14372:2011);
- c) trade name of the electrodes tested;
- d) electrode designation;
- e) electrode size;
- f) electrode drying details (temperature and time at temperature);
- g) date and time of completion of exposure;
- h) date and time of beginning of test welding;
- i) measured temperature range during exposure;
- j) measured duration of exposure;
- k) information required by ISO 3690;
- l) temperature and relative humidity at time of welding.

iTeh STANDARD PREVIEW
(standards.iteh.ai)

ISO 14372:2011

<https://standards.iteh.ai/catalog/standards/sist/b75dbcf3-dca5-467d-9f0c-55f7a086d263/iso-14372-2011>