



Designation: E618 – 07

Standard Test Method for Evaluating Machining Performance of Ferrous Metals Using an Automatic Screw/Bar Machine¹

This standard is issued under the fixed designation E618; the number immediately following the designation indicates the year of original adoption or, in the case of revision, the year of last revision. A number in parentheses indicates the year of last reapproval. A superscript epsilon (ϵ) indicates an editorial change since the last revision or reapproval.

INTRODUCTION

This test method was written to fill a requirement for a standard test for determining the machinability of ferrous metals using automatic screw/bar machines. (Hereafter, these machines will be referred to as automatic screw machines.) Although a variety of short-time laboratory tests have demonstrated different machining characteristics among ferrous metals, it has been difficult to apply the resulting data to commercial automatic screw machine practice.

In this test method a standard test piece is machined using tools and machining operations typical of automatic screw machine practice.

Through the use of this test method, the relative machining performance of a metal can be evaluated even though different automatic screw machines are used. Further, comparisons can be made among different lots of the same grade or different grades to determine relative machining performance.

1. Scope*

1.1 This test method covers a production-type test for evaluating the machining performance of ferrous metals as they are used in single-spindle or multiple-spindle automatic screw machines. It is based on producing parts of a standard design in such machines to uniform levels of quality with respect to surface roughness and size variation. The standard test piece, designed for this test, is machined from bars using a specified number of tools in a specified sequence. Nothing in this test method should be construed as defining or establishing limits of acceptability for any grade or type of metal.

1.2 The values stated in inch-pound units are to be regarded as standard. The values given in parentheses are mathematical conversions to SI units that are provided for information only and are not considered standard.

1.3 *This standard does not purport to address all of the safety concerns, if any, associated with its use. It is the responsibility of the user of this standard to establish appropriate safety and health practices and determine the applicability of regulatory limitations prior to use.*

¹ This test method is under the jurisdiction of ASTM Committee A01 on Steel, Stainless Steel and Related Alloys and is the direct responsibility of Subcommittee A01.15 on Bars.

Current edition approved May 1, 2007. Published May 2007. Originally approved in 1977. Last previous edition approved in 2001 as E618 – 81 (2001). DOI: 10.1520/E0618-07.

2. Referenced Documents

2.1 *American National Standard:*
B46.1 Surface Texture²

3. Terminology

3.1 *Definitions of Terms Specific to This Standard:*

3.1.1 *average surface roughness (per set of samples)*—for each surface (the major and minor diameter formed surfaces) the surface roughness per set of samples is the average of the roughnesses recorded as in 3.1.5.1 for the six test pieces per set. A test set is described in 9.3.

3.1.2 *calculated hourly production rate (in pieces per hour)*—3600 s/h divided by the cycle time in seconds per piece. (Unit: pieces per hour.)

3.1.3 *cycle time*—the time in seconds per piece from bar feed-out to bar feed-out, or from cutoff to cutoff, during uninterrupted operation of the machine. It includes all stock, machine, and tool movements.

3.1.4 *surface speed*—the product of the original bar circumference (in feet or metres) and the spindle speed in revolutions per minute. (Unit: ft/min or m/min.)

3.1.5 *surface-roughness average value (R_a)*—the surface-roughness average value is the mean reading around which the

² Available from American National Standards Institutes, 25 W. 43rd Street, 4th Floor, New York, NY 10036.

*A Summary of Changes section appears at the end of this standard

needle tends to dwell or fluctuate under small amplitude when a continuously averaging meter is used. (Refer to 3.8.1.1 in ANSI B46.1). The surface-roughness value obtained by a continuously averaging digital readout meter is acceptable.

3.1.5.1 The surface-roughness recorded for each surface on the test piece is the maximum of the surface-roughness average values measured on that surface at a minimum of four places equispaced around the circumference and measured as described in 3.1.5.

3.1.6 *surface-roughness range (per set of samples)*—the lowest and highest values of the surface roughnesses recorded for each surface as in 3.1.5.1 for each set.

3.1.7 *surface-roughness range (per test)*—the lowest and highest values of surface roughnesses recorded for each surface as in 3.1.5.1 during the test.

3.1.8 *theoretical hourly production rate (in pieces per hour)*—3600 s/h divided by the cycle time in seconds per piece diminished by: (1) the indexing time or high-speed time in seconds per piece for a multiple-spindle machine, or (2) the time in seconds per piece when no tools are cutting for a single-spindle machine.

3.1.9 *tool feed rate*—the distance traveled by the tool at a uniform rate divided by the number of spindle revolutions during which this travel occurs. (Units: decimal inch or decimal millimetre per revolution.)

3.1.10 *tool life (for a form tool)*—the hours of machine time determined from the calculated hourly production rate and the total number of test pieces produced from the start of the test to the earliest point at which the average of the recorded surface-roughness average values or the average of sizes of the test pieces in a sample set consistently exceed either the surface-roughness limits or the size limits specified in 9.7.1, 9.7.2, and 9.7.3 for the piece diameter produced by that tool.

3.2 Machining performance in this test method is evaluated by the following criteria:

3.2.1 Tool life as described in 3.1.10.

3.2.2 Cutting speed and tool-feed rate as described in 3.1.4 and 3.1.9.

3.2.3 Hourly rate of production as described in 3.1.2 or 3.1.8.

3.2.4 A test sample set is described in 9.3.

4. Summary of Test Method

4.1 A standard test piece, shown in Fig. 1, is machined from bar stock in an automatic screw machine.

4.2 Specified tools are used in a standard sequence to shape the test piece. Drills and form tools are used simultaneously to provide a typical machining condition during the test.

4.3 Cutting speed and tool feed rate for the metal being tested are varied from one test run to another to determine the maximum rate at which test pieces can be produced for the specified length of time without exceeding the specified limits for surface roughness and size dimensions.

4.4 When measured as specified, the level of and changes in surface roughness and the size of pieces produced are used to evaluate the machining performance of the metal being tested.

5. Significance and Use

5.1 This test method can be used to evaluate the machining performance of a single grade or type of metal or to compare one grade or type with another.

5.1.1 The machining performance of the test metal is measured by the maximum rate at which test pieces can be produced within specified surface roughness and dimensional limits for a specified length of time and also by the cutting speed and tool feed employed to attain that rate.

5.1.2 The relative machining performance of the various metals tested using this test method may be evaluated only at operating conditions that produce test pieces of like quality with respect to surface roughness and dimensional limits for comparable periods of machining time.

6. Apparatus

6.1 Automatic Screw Machine:

6.1.1 A single-spindle automatic screw machine with a six- or eight-hole turret, with adequate spindle capacity, and with sufficient feed, speed, and power to machine a 1-in. round bar of free-machining, alloy or high-strength steel, or

6.1.2 A multiple-spindle automatic screw machine with a spindle capacity and with sufficient feed, speed, and power to machine 1-in. round bars of free-machining, alloy or high-strength steel simultaneously at all spindles.

6.2 *Metal-Cutting Tools*—On the basis of current use for general applications for automatic screw-machine production, two tool-steel grades (M7 for drills and M2 for form tools) are suggested in 6.2.1 through 6.2.5. This is not intended to preclude the use of other grades. This test method does require that the use of tool materials, other than those suggested, be recorded and reported together with the reason(s) for the change.

6.2.1 A 3/4-in. (19.05-mm) diameter or larger spot drill with a 90° included point angle may be used.

6.2.2 Two 3/8-in. (9.52-mm) diameter and one 5/8-in. (15.88-mm) diameter drills ground as specified in 8.6.

6.2.3 Either a dovetail or a circular rough-form tool of M2 steel designed as shown in Fig. 2.

6.2.4 A flat, circular, or dovetail finish-form tool at least 9/16 in. (14.29 mm) wide made from M2 steel as shown in Fig. 3.

6.2.5 A cutoff tool as described in 8.5.

6.3 *Stylus-Type Standard Commercial Surface-Roughness-Measuring Instrument*, capable of measuring surface roughness in microinches arithmetic average (AA) and having a stroke of at least 1/4 in. (6.35 mm).

6.3.1 In all cases an electric cutoff of 0.030 in. (0.8 mm) is used. The stylus and skids of the tracer head must be compatible with a 0.030-in. (0.8-mm) cutoff. (See 3.6.2 in ANSI B46.1 for a definition of cutoff.)

6.3.2 The length of trace is the maximum possible on the surface being measured but must be at least 0.150 in. (3.81 mm).

6.4 *Micrometer(s)*, capable of indicating to 0.0001 in. or 0.002 mm.

6.5 *Toolmaker's Microscope* or equivalent.

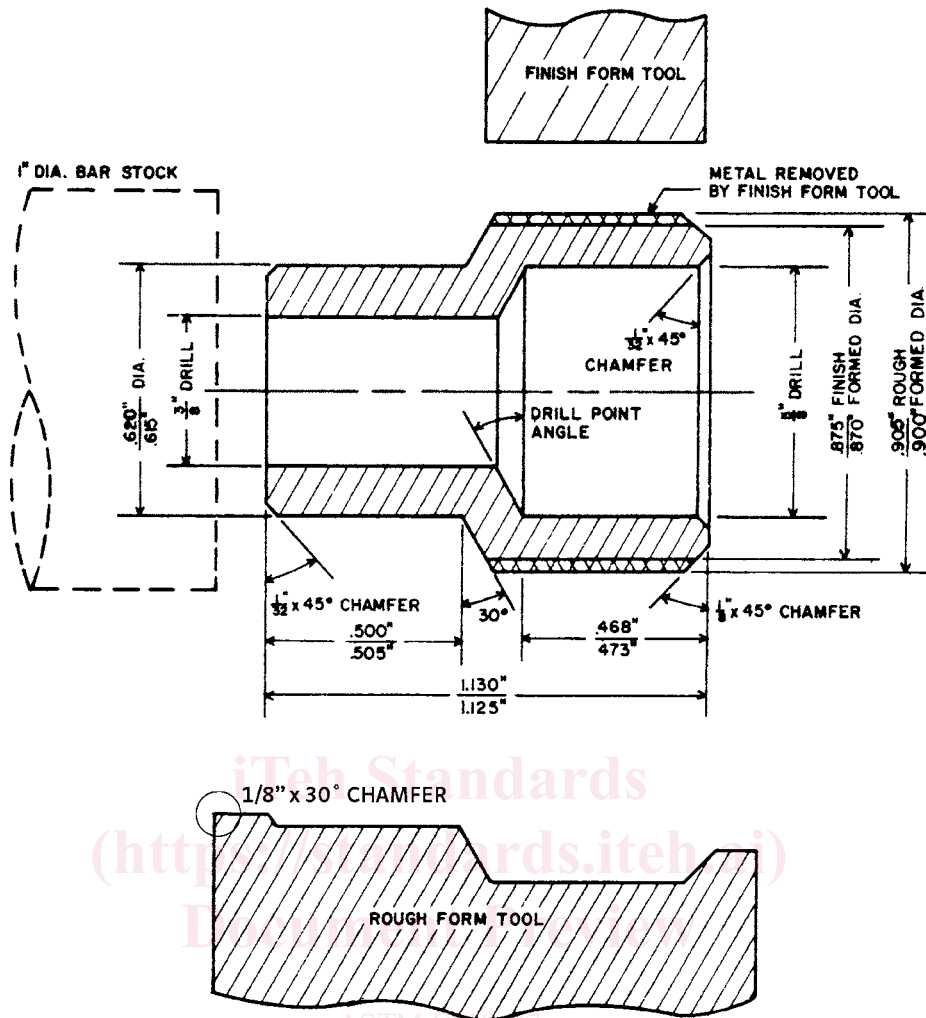

FIG. 1 Details of the ASTM Machinability Test Specimen and the Relative Positions of Form Tools

6.6 Commercially Available Coolant.

7. Test Specimen

7.1 The test specimen detailed in Fig. 1 shall be machined from 1-in. (25.4-mm) diameter bars.

7.2 Different bar sizes may be used to produce a different size test piece provided that the material removed and the material remaining is in the same cross-sectional proportion as in the test piece shown in Fig. 1. When a different bar size is used a proportionate change is made in all dimensions, except that both formed surfaces must be at least 3/8 in. (9.5 mm) long. This is to ensure accurate surface-roughness measurements.

7.3 When a different size test piece is used the bar size and test piece dimensions shall be recorded on the test report.

8. Procedure for Machine Setup

8.1 Since there is a difference between automatic screw machines as to how movement is conveyed to the end and side working tools, cams must be designed or selected to provide a uniform rate of tool feed for a distance greater than that

necessary to remove the required metal. This will ensure a uniform feed rate throughout the cut.

8.2 Feeds and speeds on the initial test run should be selected on the basis of experience or general guide lines for a ferrous metal of similar composition and condition.

8.2.1 The positive stop pressure maintained during the test shall be that which is recommended by the machine tool builder.

8.3 Place the cutting tools so they cut in the following sequence. The form tools and drills shall cut at the same time.

8.3.1 Spot drill (optional).

8.3.2 Rough form and drill to depth with 5/8-in. (15.88-mm) diameter drill.

8.3.3 Finish form to 0.875-in. (22.22-mm) outside diameter and drill 11/32 in. (8.73 mm) deep with the first 3/8-in. (9.52-mm) diameter drill.

8.3.4 Drill 11/32 in. (8.73 mm) deep (through the cutoff) with the second 3/8-in. (9.52-mm) diameter drill.

8.3.5 An optional sequence of tooling for a single-spindle automatic machine uses only three drills in the turret; namely,

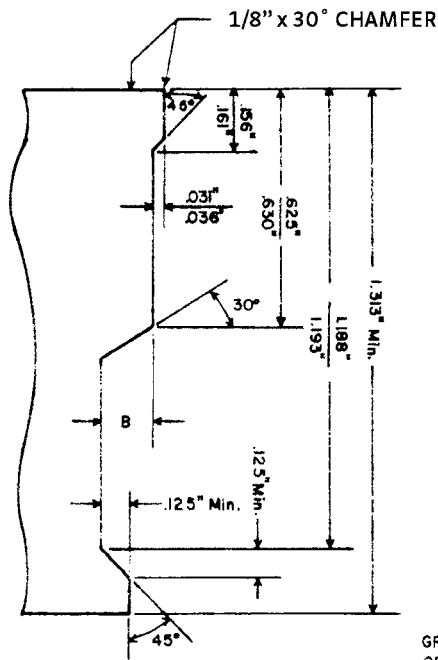

CHART FOR DETERMINING DIMENSION B AS A FUNCTION OF ANGLE A AND THE TOOL FLANK CLEARANCE WHEN THE TOOL IS IN THE CUTTING POSITION

ANGLE A	15°	22°
TOOL FLANK CLEARANCE WHEN IN CUTTING POSITION	5°	12°
DIMENSION B	.140"	.134"

ANGLE A MINUS FLANK CLEARANCE IN HOLDER PROVIDES A CONSTANT 10° BACK RAKE ANGLE. INTERPOLATE DIMENSION B FOR CLEARANCE ANGLES BETWEEN 5° AND 12°

GRIND 2° TO 4° SIDE RAKE ACROSS TOP SURFACE OF TOOL TO COMPENSATE FOR TILT IF TOOL IS TILTED IN MACHINE FOR SIDE CLEARANCE

SEC. X-X

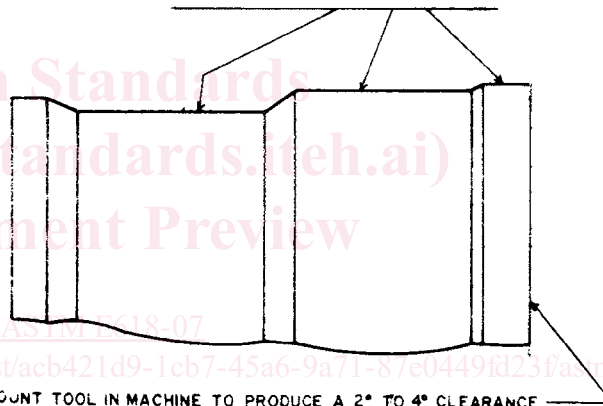
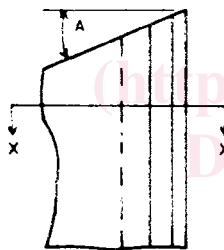

MOUNT TOOL IN MACHINE TO PRODUCE A 2° TO 4° CLEARANCE ON THIS SIDE. GRIND COMPENSATING SIDE RAKE ON TOP OF TOOL. ALTERNATE: GRIND 2° TO 4° CLEARANCE ON THIS SIDE AND MOUNT TOOL STRAIGHT IN TOOL HOLDER. NO SIDE RAKE ON TOP OF TOOL.

FIG. 2 Details of the Tool Edge for the ASTM Rough-Form Tool

one spot drill, one 5/8-in. (15.88-mm) drill, and one 3/8-in. (9.52-mm) drill with double indexing of the turret between successive drilling operations.

8.3.6 Cut off the finished piece.

8.4 Form Tool Conditions:

8.4.1 Using the most rigid cross-slide, set the rough-form tool so that the part of the tool forming the 0.615 to 0.620-in. (15.62 to 15.75-mm) or minor diameter will cut on center.

8.4.2 Set the finish-form tool to cut the rough-formed 0.900 to 0.905-in. (22.86 to 22.99-mm) or major diameter on center and remove 0.030 in. (0.76 mm) from that diameter to form the 0.870 to 0.875-in. (22.10 to 22.22-mm) diameter. When a different size test piece is used, proportionately more or less metal will be removed by the finish-form tool.

8.4.3 Grind and mount all form tools in the machine with an effective positive top rake angle of 10°, a front clearance angle of 5 to 12°, and, for the rough-form tool, a side-clearance angle of 2 to 4°. Note any deviation from these angles found necessary and record the reason. The grinding lay (direction of dominate linear surface texture) on the rake face of the rough and finish form tools shall run parallel to the leading cutting edge. This is coincident with the practice of avoiding a slight negative lip rake angle.

8.4.4 When the side-clearance angle for the rough-form tools is obtained by a tilted tool holder, it is recommended that the rough-form tool be reground in a tool holder or fixture having an identical angle of tilt.

8.4.5 All form tools must be hardened to 63 minimum HRC.

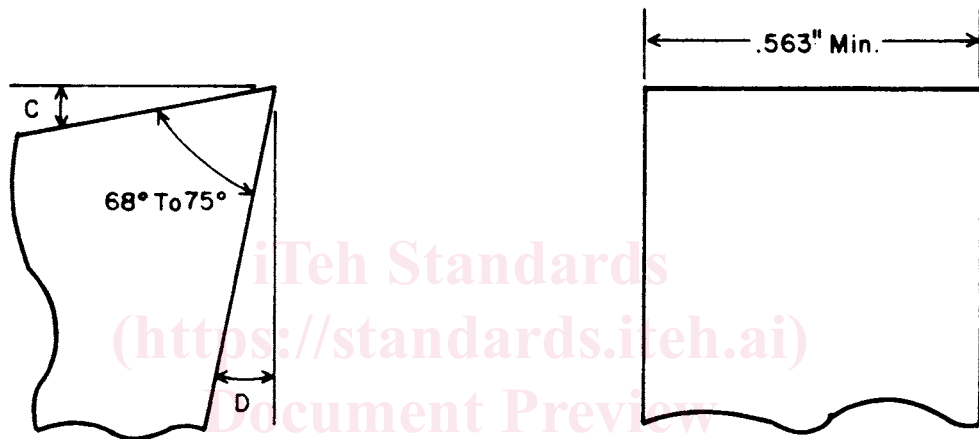
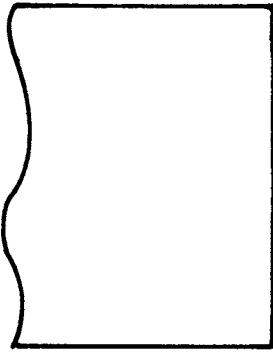

NOTE 1—Angle C: 10° positive back-rake angle when mounted in cutting position.

NOTE 2—Angle D: 5 to 12° clearance angle when mounted in cutting position.

FIG. 3 Details of the Tool Edge for the ASTM Finish-Form Tool

<https://standards.iteh.ai/catalog/standards/sis/acb421d9-1cb7-45a6-9a71-87e0449fd23f/astm-e618-07>

8.5 *Cutoff Tool*—An appropriate commercial tool shall be used.

8.6 *Drills:*

8.6.1 Use solid two-flute standard length or screw-machine length high-speed steel twist drills. Note any deviation that is found necessary to conduct the test and record the reason.

8.6.2 Included (point angles) angles shall be 118° for all metals except stainless steels and high-strength metals, when a 135° included angle shall be used.

8.6.2.1 The lip clearance angles shall be 14 ± 2° for the 3/8-in. (9.52-mm) drill(s) with 118° included angle; 12 ± 2° for the 5/8-in. (15.88-mm) drill with 118° included angle; 12 ± 2° for the 3/8-in. drill(s) with the 135° included angle; and 10 ± 2° for the 5/8-in. drill with 135° included angle.

8.6.2.2 Web thinning may be necessary when resharpening drills with 118° included angle.

8.6.2.3 Use a split point on the drills with 135° included angle.

8.6.2.4 All drills shall have the helix angle which is standard for the manufacturer of the drills.

8.7 Direct the coolant to flood the test pieces and the tool cutting edges during machining.

9. Test Method

9.1 Determine the reliability of machining-performance data to be expected on any given machine by running machine-capability tests prior to a test program to determine the tolerance limits within which the machine is capable of producing the test piece. A method for doing this is described in Appendix X1. Machine-capability tests should be performed each time a variance pattern of sizes develops which departs from the norm previously established.

9.1.1 If the machine is not capable of producing pieces within the limits specified in 9.7.2 before proceeding with the test program, adjust the machine to repeatedly produce the part size to less than the diameter-increase limits specified in 9.7.2.

9.2 This test method requires the determination of the maximum rate at which test pieces can be produced from a test metal consistent with an average 8-h form-tool life as defined in 5.1 and within the size and surface-roughness limits specified in 9.7.1, 9.7.2, or 9.7.3. Vary cutting speeds and tool-feed rates (and tool rake angles, if necessary) in successive test runs until that objective is attained. Start each test run with freshly ground tools at a selected cutting speed and tool-feed rate which may not be changed during that test run. Monitor the

progress of a test run by measuring the size and surface roughness of test pieces in sample sets taken at regular intervals.

9.2.1 Form-tool rake angles may also be varied from those specified in 8.4.3 to obtain pieces of like quality from different materials, but only if changes of cutting speed and tool-feed rate fail to produce test pieces of like quality with respect to surface roughness and dimensional limits for comparable periods of time as specified in 5.1.2. Record the variation in rake angles in the log of test data.

9.2.2 From the nature of this test method it is clear that substantial quantities of test material will be required, varying from a few hundred pounds (or kilograms) to a few thousand pounds (or kilograms), depending upon the grades selected for test. For example, free-machining steels, which will accept high cutting speeds and tool-feed rates, may easily require 1500 to 2000 lb (700 to 900 kg) of bars for a single test run, whereas a difficult-to-machine stainless might require only 150 to 200 lb (70 to 80 kg). It is probable that three or more times these quantities will be required for tests at various conditions in order to attain the objective as specified in 9.2. Considering that these are large amounts of material for a test procedure, selection of bars to ensure randomness is not necessary.

9.3 Test-Sample Sets:

9.3.1 A test-sample set from a multiple-spindle automatic screw machine consists of one test piece taken at cut-off from each spindle in numbered sequence during one complete cycle (revolution) of the spindle carriage numbered and recorded in the same order. Take and record subsequent sample sets using the same spindle sequence.

9.3.2 When a single-spindle automatic screw machine is used, take six consecutive pieces as a test-sample set.

9.3.3 Take sample sets of test pieces only after the machine has produced pieces for at least 15 min, except during machine set up.

9.4 The intervals between sample sets shall be no greater than 1 h. Discard test pieces produced in the intervals between sample sets.

9.5 Make and record (1) surface-roughness measurements on test pieces at a minimum of four locations around the circumference produced by each form tool and (2) size measurements at two locations 90° apart on each circumference.

9.6 Do not make form-tool adjustments to bring pieces within size limits during the test after the tools have been set initially to produce parts of specified dimensions.

9.7 Surface-Roughness and Size Limits:

9.7.1 The highest recommended surface-roughness average value on a test piece in a sample set is: 150 μin . R_a on finish-formed surfaces; or 300 μin . R_a on rough-formed surfaces.

9.7.2 The maximum recommended increase in diameter from the starting size on a test piece in a sample set is: 0.003 in. (0.08 mm) for the finish-formed surface (major diameter); or 0.005 in. (0.13 mm) for the rough-formed surface (minor diameter).

9.7.3 Surface-roughness and size limits different from those specified in 9.7.1 and 9.7.2 may be used provided they are clearly stated and applied equally to all tested materials.

9.8 Termination of Test Runs:

9.8.1 The tool life is determined when the conditions of 5.1 are exceeded. It is suggested that the test be continued somewhat beyond that tool-life end point in order to verify as valid that point of test termination.

9.8.2 A test run may be continued beyond the point described in 9.8.1 in order to obtain information on the other form tool. Such a continued test run is subsequently terminated when all test pieces in a sample set exceed the surface-roughness or size limit specified in 9.7.1, 9.7.2, or 9.7.3 for the other form tool. Record in the test log (Fig. X1.1) the tool life of all form tools as described in 5.1.

9.8.3 A test may also be terminated for other reasons, such as excess form tool wear or tool failure. See 10.1.4.4 and 10.1.4.8.

9.9 Do not remove form tools from the tool holders or the machine for wear measurements during these test runs.

10. Recordkeeping

10.1 Record the following data for each test conducted. A suggested form is attached as Fig. X1.1.

10.1.1 Test-Material Data:

10.1.1.1 Grade, type, or alloy designation if applicable, and chemical composition if available.

10.1.1.2 Test material condition, that is, annealed, cold-drawn, extruded, ground, ground and polished, etc., including surface condition that is, rusty, scaled, clean, etc.,

10.1.1.3 Bar diameter, and

10.1.1.4 Mechanical properties, that is, tensile strength, yield strength (0.2 % offset), reduction of area, elongation, and hardness, if available.

10.1.2 Machine Data:

10.1.2.1 Machine size, make, model and number of spindles, and

10.1.2.2 Machine-indexing or high-speed time in seconds per piece for a multiple-spindle machine, or

10.1.2.3 Time when no tools are cutting, in seconds per piece for a single-spindle machine.

10.1.3 Operating Data:

10.1.3.1 Cam rise for each tool,

10.1.3.2 Feed rate for each tool, inches (or millimetres) per revolution,

10.1.3.3 Spindle revolutions per minute,

10.1.3.4 Surface speed, feet (or metres) per minute, calculated from original bar diameter and spindle revolutions per minute,

10.1.3.5 Machine-cycle time in seconds per piece,

10.1.3.6 Calculated and theoretical production rates described in 3.1.2 and 3.1.8, pieces per hour,

10.1.3.7 Coolant used, stating trade name and number or ASTM designation, and condition (whether new or old, clean, etc.),

10.1.3.8 Sampling frequency and sample-set size, and

10.1.3.9 Tool materials for all tools.

10.1.4 Results: