



Designation: D4255/D4255M – 01(Reapproved 2007)

## Standard Test Method for In-Plane Shear Properties of Polymer Matrix Composite Materials by the Rail Shear Method<sup>1</sup>

This standard is issued under the fixed designation D4255/D4255M; the number immediately following the designation indicates the year of original adoption or, in the case of revision, the year of last revision. A number in parentheses indicates the year of last reapproval. A superscript epsilon ( $\epsilon$ ) indicates an editorial change since the last revision or reapproval.

*This standard has been approved for use by agencies of the U.S. Department of Defense.*

### 1. Scope

1.1 This test method determines the in-plane shear properties of high-modulus fiber-reinforced composite materials by either of two procedures. In Procedure A, laminates clamped between two pairs of loading rails are tested. When loaded in tension the rails introduce shear forces in the specimen. In Procedure B, laminates clamped on opposite edges with a tensile or compressive load applied to a third pair of rails in the center are tested.

1.2 Application of this test method is limited to continuous-fiber or discontinuous-fiber-reinforced polymer matrix composites in the following material forms:

1.2.1 Laminates composed only of unidirectional fibrous laminae, with the fiber direction oriented either parallel or perpendicular to the fixture rails.

1.2.2 Laminates composed only of woven fabric filamentary laminae with the warp direction oriented either parallel or perpendicular to the fixture rails.

1.2.3 Laminates of balanced and symmetric construction, with the 0° direction oriented either parallel or perpendicular to the fixture rails.

1.2.4 Short-fiber-reinforced composites with a majority of the fibers being randomly distributed.

NOTE 1—Additional test methods for determining in-plane shear properties of polymer matrix composites may be found in Test Methods [D5379/D5379M](#) and [D5448/D5448M](#), and Practice [D3518/D3518M](#).

1.3 *This standard does not purport to address all of the safety concerns, if any, associated with its use. It is the responsibility of the user of this standard to establish appropriate safety and health practices and determine the applicability of regulatory limitations prior to use.*

1.4 The values stated in either SI units or inch-pound units are to be regarded separately as standard. Within the text the inch-pounds units are shown in brackets. The values stated in

each system are not exact equivalents; therefore, each system must be used independently of the other. Combining values from the two systems may result in nonconformance with the standard.

### 2. Referenced Documents

#### 2.1 ASTM Standards:<sup>2</sup>

[D792 Test Methods for Density and Specific Gravity \(Relative Density\) of Plastics by Displacement](#)

[D883 Terminology Relating to Plastics](#)

[D2584 Test Method for Ignition Loss of Cured Reinforced Resins](#)

[D2734 Test Methods for Void Content of Reinforced Plastics](#)

[D3171 Test Methods for Constituent Content of Composite Materials](#)

[D3518/D3518M Test Method for In-Plane Shear Response of Polymer Matrix Composite Materials by Tensile Test of a  \$\pm 45^\circ\$  Laminate](#)

[D3878 Terminology for Composite Materials](#)

[D5229/D5229M Test Method for Moisture Absorption Properties and Equilibrium Conditioning of Polymer Matrix Composite Materials](#)

[D5379/D5379M Test Method for Shear Properties of Composite Materials by the V-Notched Beam Method](#)

[D5448/D5448M Test Method for Inplane Shear Properties of Hoop Wound Polymer Matrix Composite Cylinders](#)

[E4 Practices for Force Verification of Testing Machines](#)

[E6 Terminology Relating to Methods of Mechanical Testing](#)

[E111 Test Method for Young's Modulus, Tangent Modulus, and Chord Modulus](#)

[E122 Practice for Calculating Sample Size to Estimate, With Specified Precision, the Average for a Characteristic of a Lot or Process](#)

[E177 Practice for Use of the Terms Precision and Bias in ASTM Test Methods](#)

[E251 Test Methods for Performance Characteristics of Metallic Bonded Resistance Strain Gages](#)

<sup>1</sup> This test method is under the jurisdiction of ASTM Committee D30 on Composite Materials and is the direct responsibility of Subcommittee D30.04 on Lamina and Laminate Test Methods.

Current edition approved May 1, 2007. Published June 2007. Originally approved in 1983. Last previous edition approved in 2001 as D4255/D4255M – 01. DOI: 10.1520/D4255\_D4255M-01R07.

<sup>2</sup> For referenced ASTM standards, visit the ASTM website, [www.astm.org](http://www.astm.org), or contact ASTM Customer Service at [service@astm.org](mailto:service@astm.org). For *Annual Book of ASTM Standards* volume information, refer to the standard's Document Summary page on the ASTM website.

- E456 Terminology Relating to Quality and Statistics
- E1237 Guide for Installing Bonded Resistance Strain Gages
- E1309 Guide for Identification of Fiber-Reinforced Polymer-Matrix Composite Materials in Databases
- E1434 Guide for Recording Mechanical Test Data of Fiber-Reinforced Composite Materials in Databases
- E1471 Guide for Identification of Fibers, Fillers, and Core Materials in Computerized Material Property Databases
- 2.2 ASTM Adjunct:
- Adjunct No. ADJD4255, Rail Shear Fixtures Machining Drawings<sup>3</sup>

### 3. Terminology

3.1 Terminology D3878 defines terms relating to high-modulus fibers and their composites. Terminology D883 defines terms relating to plastics. Terminology E6 defines terms relating to mechanical testing. Terminology E456 and Practice E177 define terms relating to statistics. In the event of a conflict between terms, Terminology D3878 shall have precedence over the other terminology standards.

NOTE 2—If the term represents a physical quantity, its analytical dimensions are stated immediately following the term (or letter symbol) in fundamental dimension form, using the following ASTM standard symbology for fundamental dimensions, shown within square brackets: [M] for mass, [L] for length, [T] for time, [θ] for thermodynamic temperature, and [nd] for nondimensional quantities. Use of these symbols is restricted

<sup>3</sup> A copy of the detailed drawing for the construction of the fixtures shown in Figs. 1 and 2 is available at a nominal cost from ASTM Headquarters. Request Adjunct No. ADJD4255.

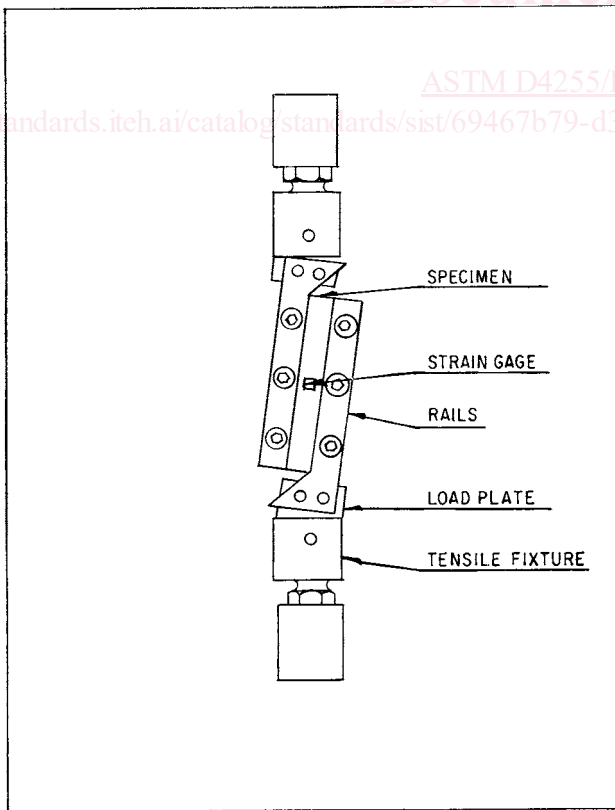

FIG. 1 Procedure A Assembly Rail Shear Apparatus

to analytical dimensions when used with square brackets, as the symbols may have other definitions when used without the brackets.

#### 3.2 Definitions of Terms Specific to This Standard:

3.2.1 *in-plane shear*,  $n$ —shear associated with shear forces applied to the edges of the laminate so that the resulting shear deformations occur in the plane of the laminate rather than through the thickness.

3.2.2 *offset shear stress*  $[M/(LT^2)]$ ,  $n$ —the shear stress associated with an offset of the shear chord modulus of elasticity line along the strain axis (see 12.4).

3.2.3 *shear strength*  $[M/(LT^2)]$ ,  $n$ —the shear stress carried by a material at failure under a pure shear condition.

3.2.4 *transition region*,  $n$ —a strain region of a stress-strain or strain-strain curve over which a significant change in the slope of the curve occurs within a small strain range.

3.2.4.1 *Discussion*—Many filamentary composite materials exhibit a nonlinear response during loading, such as seen in plots of either longitudinal stress versus longitudinal strain or transverse strain versus longitudinal strain. In certain cases, the nonlinear response may be conveniently approximated by a bilinear fit. There are several physical reasons for the existence of a transition region. Common examples include matrix cracking under tensile loading and ply delamination.

3.2.5 *traveler*,  $n$ —a small piece of the same material as, and processed similarly to, the test specimen, used for example to measure moisture content as a result of conditioning. This is also sometimes termed as a reference sample.

3.3 *Symbols*:  $A$  = cross-sectional area of test specimen

$B_y$  = percent bending of specimen

$CV$  = coefficient of variation statistic of a sample population for a given property, %

$F_{12}^o$  = offset shear stress, the value of the shear stress at the intersection of the stress-strain plot with a line passing through the offset strain value at zero stress and with a slope equal to the shear chord modulus of elasticity

$F^u$  = ultimate shear stress

$G$  = shear modulus of elasticity

$h$  = specimen thickness

$l$  = specimen length, the dimension parallel to the rails in the gage section

$n$  = number of specimens

$P_i$  = load carried by test specimen at  $i$ th data point

$P^{max}$  = load carried by a test specimen that is the lesser of (1) the maximum load before failure, (2) the load at 5% shear strain, or (3) the load at the bending limit (see 11.8.1)

$s_{n-1}$  = sample standard deviation

$x_i$  = measured or derived property for an individual specimen from the sample population

$\bar{x}$  = sample mean (average)

$\gamma$  = shear strain

$\epsilon$  = indicated normal strain from strain transducer

$\mu\epsilon = 10^{-6} \text{ m/m } (10^{-6} \text{ in./in.})$

$\tau_i$  = shear stress at  $i$ th data point

### 4. Summary of Test Method

4.1 *Procedure A: Two-Rail Shear Test*—A flat panel with holes along opposing edges is clamped, usually by through

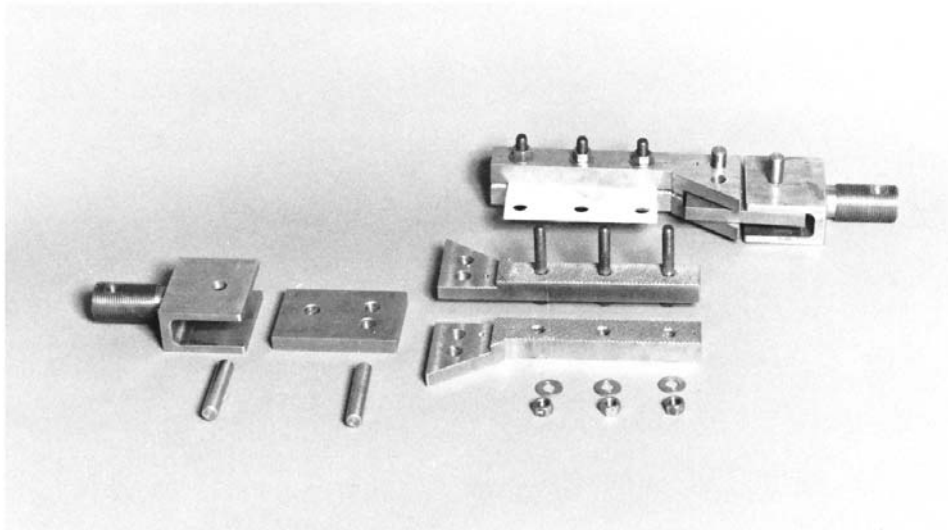

FIG. 2 Procedure A Partially Assembled Typical Test Fixture

bolts, between two pairs of parallel steel loading rails, see Figs. 1 and 2. When loaded in tension, this fixture introduces shear forces in the specimen that produce failures across the panel. This test method is typical but not the only configuration usable. The two-rail shear fixtures can also be compression loaded. The load may be applied to failure.

4.1.1 If load-strain data are required, the specimen may be instrumented with strain gages. Two three-element strain gage rosettes are installed at corresponding locations on both faces of the specimen.

4.2 Procedure B: Three-Rail Shear Test—A flat panel, clamped securely between pairs of rails on opposite edges and in its center, is loaded by supporting the side rails while loading the center rails. See Figs. 3-5. A load on the center rail of either tension or compression produces a shear load in each section of the specimen. The load may be applied to failure.

4.2.1 The test fixture consists of three pairs of parallel rails usually bolted to the test specimen by through bolts. The two outside pairs of rails are attached to a base plate which rests on the test machine. A third pair (middle rails) is guided through a slot in the top of the base fixture. The unit is normally loaded in compression. It is also permissible to load the middle rails in tension, but this requires attaching the base fixture to the test machine.

4.2.2 If load-strain data are required, the specimen may be instrumented with strain gages. Three-element strain gage rosettes are to be installed at corresponding locations on opposite faces of the specimen.

4.3 Detailed fixture drawings are available as ASTM Adjunct No. ADJD4255.

## 5. Significance and Use

5.1 These shear tests are designed to produce in-plane shear property data for material specifications, research and development, and design. Factors that influence the shear response and should therefore be reported include: material, methods of material preparation and lay-up, specimen stacking sequence, specimen preparation, specimen conditioning, envi-

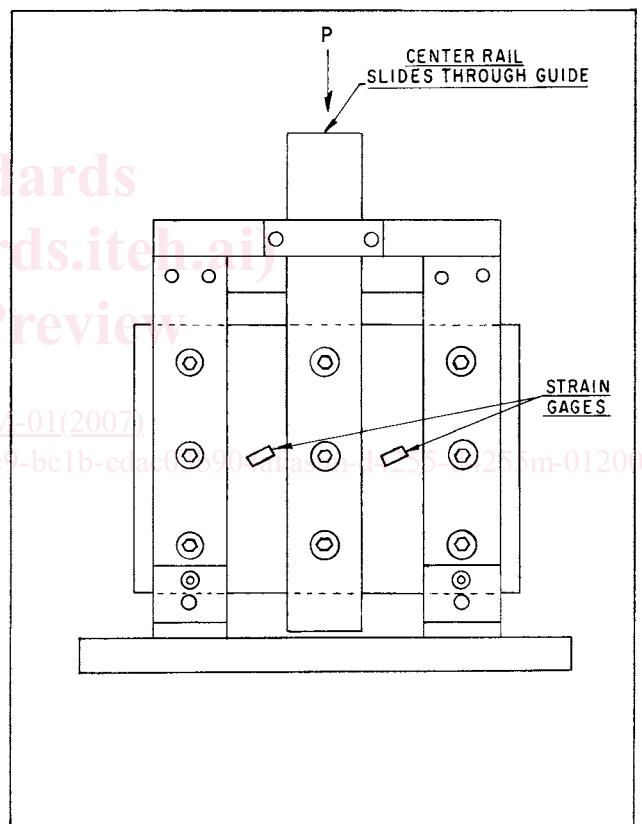

FIG. 3 Procedure B Assembly Rail Shear Fixture

ronment of testing, specimen alignment and gripping, speed of testing, time at temperature, void content, and fiber volume reinforcement content. Properties that may be measured by this test method include:

- 5.1.1 In-plane shear stress versus shear strain response,
- 5.1.2 In-plane shear chord modulus of elasticity,
- 5.1.3 Offset shear stress, and

influenced by specimen buckling. Failure by buckling should not be interpreted as indicating the maximum shear strength.

6.3.1 Ply delamination is another possible failure mode for laminates containing a large number of 45° plies. This failure reflects instability of 45° plies loaded in compression as contrasted to the overall buckling failure previously described. Differences in strain gage readings will not be noticeable, but the failure can be identified by delaminated plies in contrast to fiber breakage.<sup>4</sup>

6.4 *Gripping*—Failure through bolt holes indicates inadequate gripping. Alternate gripping methods are discussed in 7.2.3.

6.5 *End Effects*—This test method assumes a state of pure shear throughout the length of the specimen gage section. However, the gage section ends have zero shear stress because no traction and no constraints are applied there. A stress transition region exists between the ends and interior portions of the gage section. The length of this transition region determines the error induced in the material shear data.

## 7. Apparatus

7.1 *Micrometers*—The micrometer(s) shall use a suitable size diameter ball interface on irregular surfaces such as the bag-side of a laminate and a flat anvil interface on machined edges or very-smooth tooled surfaces. The accuracy of the instruments shall be suitable for reading to within 1 % of the sample length and thickness. For typical specimen geometries, an instrument with an accuracy of  $\pm 2.5 \mu\text{m}$  [ $\pm 0.0001 \text{ in.}$ ] is desirable for thickness measurement, while an instrument with an accuracy of  $\pm 25 \mu\text{m}$  [ $\pm 0.001 \text{ in.}$ ] is desirable for length measurement.

### 7.2 Rail Shear Fixtures

7.2.1 *Two-Rail Shear*—A two-rail shear fixture is shown in Figs. 1 and 2. Detailed fixture drawings are available as ASTM Adjunct No. ADJD4255. The test fixture consists of two pairs of rails which can clamp the test specimen with through bolts. The rails are then attached to the test machine through pins, a load plate that also aligns the rails with each other, and a clevis that connects directly to the test machine. This equipment is typical but not the only configuration usable. The two-rail shear fixture can be compression loaded. Also see 7.2.3 for rail modifications.

7.2.2 *Three-Rail Shear*—A three-rail shear fixture is shown in Figs. 3-5. Detailed fixture drawings are available as ASTM Adjunct ADJD4255. The test fixture consists of three pairs of rails that clamp the test specimen with through bolts. The two outside pairs of rails are attached to a base plate that rests on the test machine. The third (middle) pair of rails are guided through a slot in the top of the base fixture. The unit shown is loaded in compression. The middle rails can be tensile loaded, which requires fastening the base fixture to the test machine. This equipment is typical but not the only configuration that is usable. Also see 7.2.3 for rail modifications.

<sup>4</sup> A. K. Hussain and D. F. Adams, "The Wyoming-Modified Two-Rail Shear Test Fixture for Composite Materials," *Journal of Composites Technology and Research*, Vol 21, No. 4, October 1999, pp. 215-223.

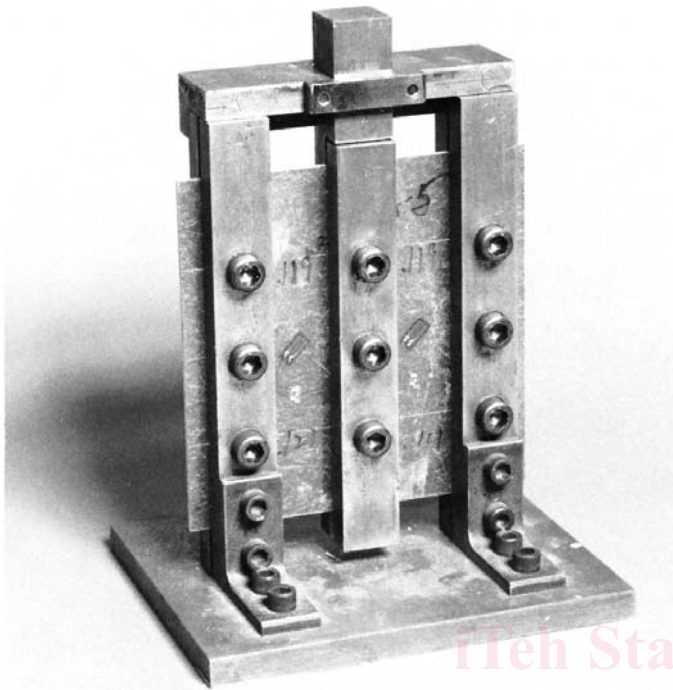

FIG. 4 Procedure B Assembled Typical Test Fixture

5.1.4 Maximum in-plane shear stress. In cases in which the strain at failure is greater than 5 %, the shear stress corresponding to 5 % shear strain should be reported.

## 6. Interferences

6.1 There are no standard test methods capable of producing a perfectly pure and uniform shear stress condition to failure for every material, although some test methods can come acceptably close for a specific material for a given engineering purpose. The off-axis load of the two-rail method introduces a comparatively small tensile load in the panel.

6.2 *Material and Specimen Preparation*—Poor material fabrication practices, lack of control of fiber alignment, and damage induced by improper specimen machining are known causes of high material data scatter in composites.

6.3 *Determination of Failure*—Rail shear specimens, especially thin ones, can buckle during load application. Buckling can be detected by measuring surface strains on opposite faces of the specimens with three-element strain gage rosettes. Data measured with the specimen in a buckled state are not representative of the material shear properties. Modulus data must be checked to confirm that buckling has not occurred in the modulus measurement range. Strength measurements must be checked to confirm that shear strength has not been



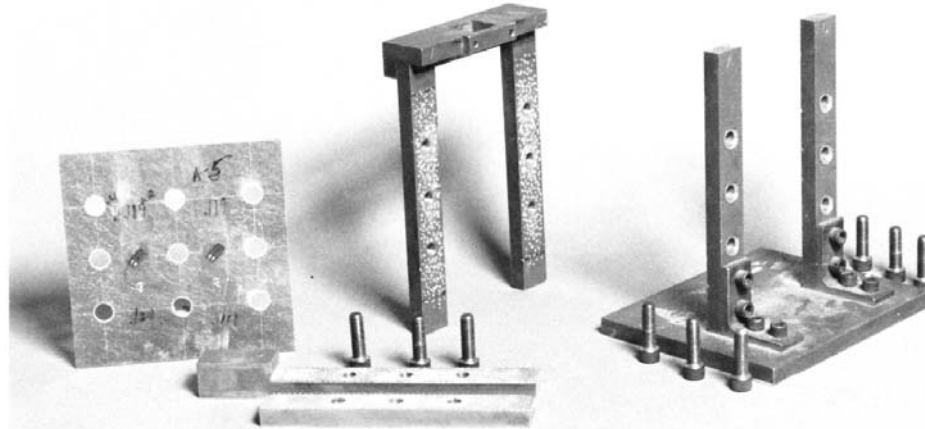

FIG. 5 Procedure B Disassembled Typical Test Fixture

iTeh Standards

7.2.3 *Rail Modifications*—The following list is not inclusive but is typical of methods used by various laboratories to meet the requirements of specific materials. Techniques that work for one material may be unacceptable for another. If these modifications are to be used as part of a specification, the rail grip system shall be completely specified and these modifications noted in the test report. These modifications have been used to grip the following specimens:

- 7.2.3.1 Abrasive paper or cloth bonded to the rails,
- 7.2.3.2 Machining V grooves in the rails,
- 7.2.3.3 Center punching rails in a random pattern,
- 7.2.3.4 Changing the number of bolt holes from three up to eight per rail and using smaller holes,
- 7.2.3.5 Soft metal shims,
- 7.2.3.6 Tabbing specimens in rail areas, and
- 7.2.3.7 Thermal spray surfaces.

7.3 *Testing Machine*—The testing machine shall conform with Practices E4 and shall satisfy these requirements:

7.3.1 *Testing Machine Heads*—The testing machine shall have two loading heads with at least one movable head along the testing axis.

7.3.2 *Platens/Adapter*—One of the testing machine heads shall be capable of being attached to the lower half of the two-rail shear test fixture (described in 7.2.1) or of supporting the base of the three-rail fixture (described in 7.2.2) using an adapter or platen interface as required. The other head shall be capable of being attached to the upper half of the fixture or of loading the center rail of the fixture. If required, one of the interfaces may be capable of relieving minor misalignments between heads, such as with a universal or a hemispherical ball joint.

7.3.3 *Drive Mechanism*—The testing machine drive mechanism shall be capable of imparting to the movable head a controlled displacement rate with respect to the stationary head. The displacement of the movable head shall be capable of regulation as specified in 11.3.

7.3.4 *Load Indicator*—The testing machine load-sensing device shall be capable of indicating the total load applied to the test specimen. This device shall be essentially free from response lag at the specified testing rate and shall indicate the load with an accuracy over the load range(s) of interest of within  $\pm 1\%$  of the indicated value, as specified by Practices E4. The load range(s) of interest may be fairly low for modulus evaluation or much higher for strength evaluation, or both, as required.

NOTE 3—Obtaining precision load data over a large range of interest in the same test, such as when both elastic modulus and maximum load are being determined, places extreme requirements on the load cell and its calibration. For some equipment a special calibration may be required. For some combinations of material and load cell, simultaneous precision measurement of both elastic modulus and maximum strength may not be possible, and measurement of modulus and strength may have to be performed in separate tests using a different load cell range for each test.

7.4 *Strain-Indicating Device*—Bonded resistance strain gages shall be used to measure strain. A minimum of two three-element strain gage rosettes are required, at corresponding locations on opposite faces of the specimen at the center of the gage section, as illustrated in Fig. 1, Fig. 3, and Figs. 6-9.

7.4.1 *Bonded Resistance Strain Gages*—Strain gage selection is a compromise based on the type of material. An active gage length of 3 mm [0.125 in.] is recommended for most materials, although larger gages may be more suitable for some woven fabrics. The gage should not be so large that it lies

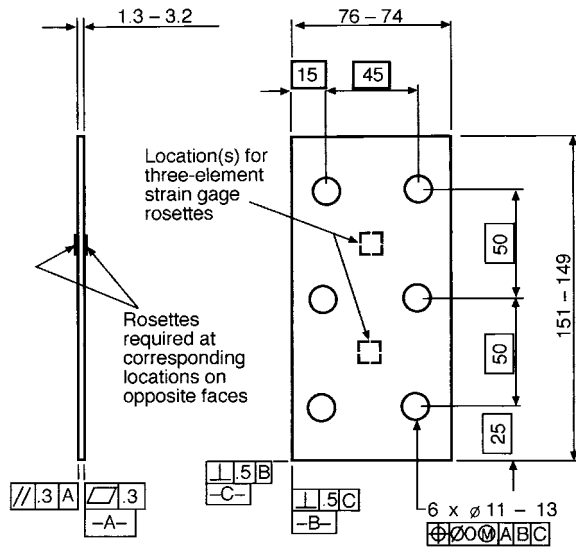

FIG. 6 Procedure A, Two-Rail Shear Specimen, SI Units

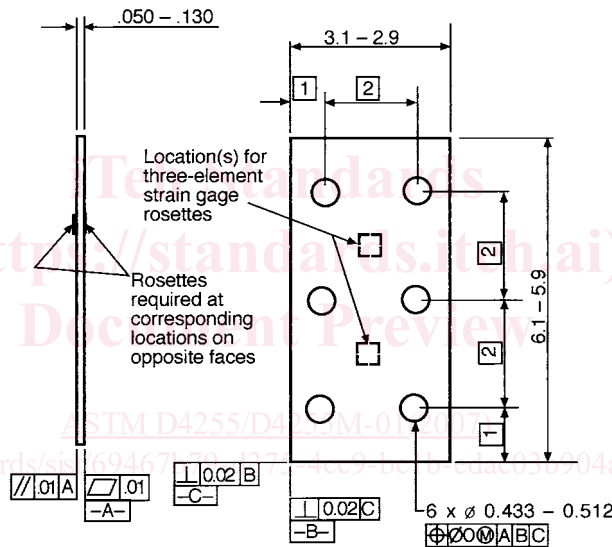

FIG. 7 Procedure A, Two-Rail Shear Specimen, Inch-Pound Units

within four specimen thicknesses of a rail. Gage calibration certification shall comply with Test Methods E251. Strain gage rosettes with a minimum normal strain range of approximately 3 % (measuring 6 % shear strain) are recommended. When testing woven fabric laminates, gage selection should consider the use of an active gage length that is at least as large as the characteristic repeating unit of the weave. Some guidelines on strain gage use on composites follow. Additional general information can be found in the literature.<sup>5,6</sup>

7.4.1.1 Surface preparation of fiber-reinforced composites in accordance with Guide E1237 can penetrate the matrix material and cause damage to the reinforcing fibers, resulting

<sup>5</sup> M. E. Tuttle and H. F. Brinson, "Resistance-Foil Strain Gage Technology as Applied to Composite Materials," *Experimental Mechanics*, 1984, Vol 24, No. 1, pp. 54-65, Errata noted in Vol. 26, No. 2, June 1986, pp. 153-154.

<sup>6</sup> *Manual on Experimental Methods of Mechanical Testing of Composites*, C. H. Jenkins, Ed., second edition, Society for Experimental Mechanics, Section II, Strain Measurement, 1998, pp. 25-84.

in improper specimen failures. Reinforcing fibers should not be exposed or damaged during the surface preparation process. Consult the strain gage manufacturer regarding surface preparation guidelines and recommended bonding agents for composites, pending the development of a set of standard practices for strain gage installation surface preparation of fiber-reinforced composite materials.

7.4.1.2 Select gages having higher resistances to reduce heating effects on low-conductivity materials.<sup>7</sup> Resistances of 350 Ω or higher are preferred. Use the minimum possible gage excitation voltage consistent with the desired accuracy (1 to 2 V is recommended) to reduce the power consumed by the gage further. Heating of the specimen by the gage may affect the performance of the material directly, or it may affect the

<sup>7</sup> D. F. Adams and E. Q. Lewis, "Influence of Specimen Gage Length and Loading Method on the Axial Compression Strength of a Unidirectional Composite Material," *Experimental Mechanics*, Vol 31, No. 1, 1991, pp. 14-20.