



Designation: D 4253 – 00

Standard Test Methods for Maximum Index Density and Unit Weight of Soils Using a Vibratory Table¹

This standard is issued under the fixed designation D 4253; the number immediately following the designation indicates the year of original adoption or, in the case of revision, the year of last revision. A number in parentheses indicates the year of last reapproval. A superscript epsilon (ϵ) indicates an editorial change since the last revision or reapproval.

1. Scope *

1.1 These test methods cover the determination of the maximum-index dry density/unit weight of cohesionless, free-draining soils using a vertically vibrating table. The adjective “dry before density or unit weight is omitted in the title and remaining portions of this standard to be consistent with the applicable definition given in Section 3 on Terminology.

1.2 Systems of Units:

1.2.1 The testing apparatus described in this standard has been developed and manufactured using values in the gravitational or inch-pound system. Therefore, test apparatus dimensions and mass given in inch-pound units are regarded as the standard.

1.2.2 It is common practice in the engineering profession to concurrently use pounds to represent both a unit of mass (lbm) and a unit of force (lbf). This implicitly combines two separate systems of units; that is, the absolute system and the gravitational system. It is scientifically undesirable to combine the use of two separate sets of inch-pound units within a single standard. This standard has been written using the gravitational system of units when dealing with the inch-pound system. In this system, the pound (lbf) represents a unit of force (weight). However, balances or scales measure mass; and weight must be calculated. In the inch-pound system, it is common to assume that 1 lbf is equal to 1 lbm. While reporting density is not regarded as nonconformance with this standard, unit weights should be calculated and reported since the results may be used to determine force or stress.

1.2.3 The terms density and unit weight are often used interchangeably. Density is mass per unit volume whereas unit weight is force per unit volume. In this standard density is given only in SI units. After the density has been determined, the unit weight is calculated in SI or inch-pound units, or both.

1.3 Four alternative methods are provided to determine the maximum index density/unit weight, as follows:

1.3.1 *Method 1A*—Using oven-dried soil and an electromagnetic, vertically vibrating table.

¹ This standard is under the jurisdiction of ASTM Committee D18 on Soil and Rock and are the direct responsibility of Subcommittee D18.03 on Texture, Plasticity, and Density Characteristics of Soils.

Current edition approved June 10, 2000. Published September 2000. Originally published as D 4253 – 83 . Last previous edition D 4253 – 93 (1996).

1.3.2 *Method 1B*—Using wet soil and an electromagnetic, vertically vibrating table.

1.3.3 *Method 2A*—Using oven-dried soil and an eccentric or cam-driven, vertically vibrating table.

1.3.4 *Method 2B*—Using wet soil and an eccentric or cam-driven vertically vibrating table.

1.4 The method to be used should be specified by the individual assigning the test.

1.4.1 The type of table to be used (Method 1 or 2) is likely to be decided based upon available equipment.

NOTE 1—There is evidence to show that electromagnetic tables yield slightly higher values of maximum index density/unit weight than the eccentric or cam-driven tables.

1.4.2 It is recommended that both the dry and wet methods (Methods 1A and 1B or 2A and 2B) be performed when beginning a new job or encountering a change in soil types, as the wet method can yield significantly higher values of maximum index density/unit weight for some soils. Such a higher maximum index density, when considered along with the minimum index density/unit weight, Test Methods D 4254, will be found to significantly affect the value of the relative density (3.2.8) calculated for a soil encountered in the field. While the dry method is often preferred because results can usually be obtained more quickly, as a general rule the wet method should be used if it is established that it produces maximum index densities/unit weights that would significantly affect the use/application of the value of relative density.

1.5 These test methods are applicable to soils that may contain up to 15 %, by dry mass, of soil particles passing a No. 200 (75- μ m) sieve, provided they still have cohesionless, free-draining characteristics (nominal sieve dimensions are in accordance with Specification E 11). Further, these test methods are applicable to soils in which 100 %, by dry mass, of soil particles pass a 3-in. (75-mm) sieve.

1.5.1 Soils, for the purpose of these test methods, shall be regarded as naturally occurring cohesionless soils, processed particles, or composites or mixtures of natural soils, or mixtures of natural and processed particles, provided they are free draining.

1.6 These test methods will typically produce a higher maximum dry density/unit weight for cohesionless, free-draining soils than that obtained by impact compaction in

*A Summary of Changes section appears at the end of this standard.

which a well-defined moisture-density relationship is not apparent. However, for some soils containing between 5 and 15 % fines, the use of impact compaction (Test Methods D 698 or D 1557) may be useful in evaluating what is an appropriate maximum index density/unit weight.

1.7 For many types of free-draining, cohesionless soils, these test methods cause a moderate amount of degradation (particle breakdown) of the soil. When degradation occurs, typically there is an increase in the maximum index density/unit weight obtained, and comparable test results may not be obtained when different size molds are used to test a given soil.

1.8 *This standard does not purport to address all of the safety concerns, if any, associated with its use. It is the responsibility of the user of this standard to establish appropriate safety and health practices and determine the applicability of regulatory limitations prior to use.*

2. Referenced Documents

2.1 ASTM Standards:

- C 127 Test Method for Specific Gravity and Absorption of Coarse Aggregate²
- D 422 Test Method for Particle-Size Analysis of Soils³
- D 653 Terminology Relating to Soil, Rock and Contained Fluids³
- D 698 Test Method for Laboratory Compaction Characteristics of Soil Using Standard Effort (12 400 ft-lbf/ft³ (600 kN-m/m³))
- D 854 Test Methods for Specific Gravity of Soil Solids by Water Pycnometer³
- D 1140 Test Methods for Amount of Materials in Soils Finer Than the No. 200 (75- μ m) Sieve³
- D 1557 Test Method for Laboratory Compaction Characteristics of Soil Using Modified Effort (56 000 ft-lbf/ft³ (2700 kN-m/m³))
- D 2216 Test Method for Laboratory Determination of Water (Moisture) Content of Soil and Rock by Mass³
- D 2487 Practice for Classification of Soils for Engineering Purposes (Unified Soil Classification System)³
- D 2488 Practice for Description and Identification of Soils (Visual-Manual Procedure)³
- D 3740 Practice for Minimum Requirements for Agencies Engaged in the Testing and/or Inspection of Soil and Rock as Used in Engineering Design and Construction³
- D 4254 Test Methods for Minimum Index Density and Unit Weight of Soils and Calculation of Relative Density³
- D 4753 Specification for Evaluating, Selecting, and Specifying Balances and Scales for Use in Testing Soil, Rock, and Related Construction Materials³
- D 6026 Practice for Using Significant Digits in Geotechnical Data⁴
- E 11 Specification for Wire-Cloth Sieves for Testing Purposes⁵
- E 177 Practice for Use of the Terms Precision and Bias in

ASTM Test Methods⁵

E 691 Practice for Conducting and Interlaboratory Study to Determine the Precision of a Test Method⁵

3. Terminology

3.1 *Definitions:* For common definitions in this standard refer to Terminology D 653.

3.2 *Definitions of Terms Specific to This Standard:*

3.2.1 *dry density/unit weight, ρ_d or γ_d , n* —the dry density/unit weight of a soil deposit or fill at the given void ratio.

3.2.2 *given void ratio, e , n* —the in situ or stated void ratio of a soil deposit or fill.

3.2.3 *maximum index density/unit weight, ρ_{dmax} or γ_{dmax} , n* —the reference dry density/unit weight of a soil in the densest state of compactness that can be attained using a standard laboratory compaction procedure that minimizes particle segregation and breakdown.

3.2.4 *maximum index void ratio, e_{max} , n* —the reference void ratio of a soil at the minimum index density/unit weight.

3.2.5 *minimum index density/unit weight, ρ_{dmin} or γ_{dmin} , n* —the reference dry density/unit weight of a soil in the loosest state of compactness at which it can be placed using a standard laboratory procedure which prevents bulking and minimizes particle segregation.

3.2.6 *minimum index void ratio, e_{min} , n* —the reference void ratio of a soil at the maximum index density/unit weight.

3.2.7 *relative density, D_d , n* —the ratio, expressed as a percentage, of the difference between the maximum index void ratio and any given void ratio of a cohesionless, free-draining soil; to the difference between its maximum and minimum index void ratios. The equation is as follows:

$$D_d = \frac{e_{max} - e}{e_{max} - e_{min}} \times 100 \quad (1)$$

or, in terms of corresponding dry densities

$$D_d = \frac{\rho_{dmax} (\rho_d - \rho_{dmin})}{\rho_d (\rho_{dmax} - \rho_{dmin})} \times 100 \quad (2)$$

in terms of corresponding or dry unit weights

$$D_d = \frac{\gamma_{dmax} (\gamma_d - \gamma_{dmin})}{\gamma_d (\gamma_{dmax} - \gamma_{dmin})} \quad (3)$$

3.2.8 *percent compaction or relative compaction, R_c , n* —the ratio, expressed as a percentage, of the dry density/unit weight of a given soil to its maximum index density/unit weight. The equation is:

$$R_c = \frac{\rho_d}{\rho_{dmax}} \times 100 \quad (4)$$

or

$$R_c = \frac{\gamma_d}{\gamma_{dmax}} \times 100 \quad (5)$$

3.2.9 *density index, I_d* —the ratio, expressed as a percentage, of the difference between any given dry density/unit weight and the minimum index density/unit weight of a given cohesionless soil to the difference between its maximum and minimum index densities/unit weights. The equation is:

$$I_d = \frac{\rho_d - \rho_{dmin}}{\rho_{dmax} - \rho_{dmin}} \times 100 \quad (6)$$

² Annual Book of ASTM Standards, Vol 04.02.

³ Annual Book of ASTM Standards, Vol 04.08.

⁴ Annual Book of ASTM Standards, Vol 04.09.

⁵ Annual Book of ASTM Standards, Vol 14.02.

or

$$I_d = \frac{\gamma_d - \gamma_{dmin}}{\gamma_{dmax} - \gamma_{dmin}} \quad (7)$$

4. Summary of Test Method

4.1 The maximum index density/unit weight of a given free-draining soil is determined by placing either oven-dried or wet soil in a mold, applying a 2-lb/in.² (14-kPa) surcharge (dead weight) to the surface of the soil, and then vertically vibrating the mold, soil, and surcharge. Use either an electromagnetic, eccentric, or cam-driven vibrating table having a sinusoid-like time-vertical displacement relationship at a double amplitude of vertical vibration (peak-to-peak) of about 0.013 in. (0.33 mm) for 8 min at 60 Hz or about 0.019 in. (0.48 mm) for 10 min at 50 Hz. The maximum index density/unit weight is calculated by dividing the oven-dried mass/weight of the densified soil by its volume (average height of densified soil times area of mold).

5. Significance and Use

5.1 For many cohesionless, free-draining soils, the maximum index density/unit weight is one of the key components in evaluating the state of compactness of a given soil mass that is either naturally occurring or placed by man (fill).

5.1.1 Relative density and percent compaction are commonly used for evaluating the state of compactness of a given soil mass. Density/unit weight index is also sometimes used. See Section 3 for descriptions of terms.

5.2 It is generally recognized that either relative density or percent compaction is a good indicator of the state of compactness of a given soil mass. However, the engineering properties, such as strength, compressibility, and permeability of a given soil, compacted by various methods to a given state of compactness can vary considerably. Therefore, considerable engineering judgment must be used in relating the engineering properties of soil to the state of compactness.

5.3 An absolute maximum density/unit weight is not necessarily obtained by these test methods.

NOTE 2—In addition, there are published data to indicate that these test methods have a high degree of variability.⁶ However, the variability can be greatly reduced by careful calibration of equipment, including the vibrating table, and careful attention to proper test procedure and technique.

NOTE 3—The quality of the result produced by this standard is dependent on the competence of the personnel performing it, and the suitability of the equipment and facilities used. Agencies that meet the criteria of Practice D 3740, generally, are considered capable of competent and objective testing/sampling/inspection/etc. Users of this standard are cautioned that compliance with Practice D 3740 does not in itself assure reliable results. Reliable results depend on many factors; Practice D 3740 provides a means of evaluating some of those factors.

5.4 The double amplitude of vertical vibration has been found to have a significant effect on the density obtained.⁶ For a particular vibrating table and mold assembly, the maximum index density/unit weight of a given material may be obtained at a double amplitude of vibration other than the double

amplitude of 0.013 ± 0.002 in. (0.33 ± 0.05 mm) at a frequency of 60 Hz or 0.019 ± 0.003 in. (0.48 ± 0.08 mm) at 50 Hz required in this method; that is, dry density/unit weight may initially increase with increasing double amplitude of vibration, reach a peak, and then decrease with further increases in double amplitude of vibration. Furthermore, the relationship between the peak density/unit weight and optimum double amplitude of vibration (double amplitude of vibration where peak density/unit weight occurs) can vary with various soil types and gradations. For this reason, these methods allow the use of double amplitudes of vibration other than that described above, in special circumstances as provided in 11.1.6.3.

5.5 The use of the standard molds (6.1.1) has been found to be satisfactory for most soils requiring maximum index-density/unit weight testing. Special molds (6.1.2) shall only be used when the test results are to be applied in conjunction with design or special studies and there is not enough soil to use the standard molds. Such test results should be applied with caution as maximum index densities/unit weights obtained with the special molds may not agree with those that would be obtained using the standard molds.

6. Apparatus

6.1 *Mold Assembly*—An example of a typical mold assembly is shown in Fig. 1. Individual components and accessories shall be as follows:

6.1.1 *Standard Molds*—Cylindrical metal molds having nominal volumes of 0.100 ft³ (2 830 cm³) and 0.500 ft³ (14 200 cm³). The molds shall conform to the requirements shown in Fig. 2. The actual volume of the molds shall be within ±1.5 % of the specified nominal volume.

6.1.2 *Special Molds*—Cylindrical metal molds having a capacity less than 0.100 ft³ (2 830 cm³), an inside diameter equal to or greater than 2¾ in. (70 mm), but less than 4 in. (100 mm) and conforming to the design methodology presented in Fig. 3. Such molds may only be used when the test results are to be used in conjunction with design or other special studies or both, and there is not enough soil to use the 0.100 ft³ (2 830 cm³) mold.

6.1.3 *Guide Sleeves*—One guide sleeve with clamp assembly, or other suitable attachment devices [see Fig. 4(a)], for each size mold. For easy centering of the guide sleeve above the mold, two of the three setscrews on the clamp assembly should be provided with lock nuts.

6.1.4 *Surcharge Base Plates*—One surcharge base plate for each standard size mold, conforming to the requirements of Fig. 5.

6.1.5 *Surcharge Weights*—One surcharge weight for each size mold. See Fig. 5 for tolerances related to the 0.100 ft³ (2 830 cm³) and 0.500 ft³ (14 200 cm³) molds. For special molds, similar tolerances should be maintained. The total mass of the surcharge base plate and surcharge weight shall be equivalent to a surcharge stress of 2.00 ± 0.02 lb/in.² (13.8 ± 0.1 kPa) for the mold being used. For special molds, the surcharge weight can be composed of a single solid mass of metal.

6.1.6 *Surcharge Base-Plate Handle*—A device used to initially place and then to remove the surcharge base plate upon

⁶ E. T. Selig and R. S. Ladd, eds., *Evaluation of Relative Density and its Role in Geotechnical Projects Involving Cohesionless Soils*, ASTM STP 523, ASTM, 1973.

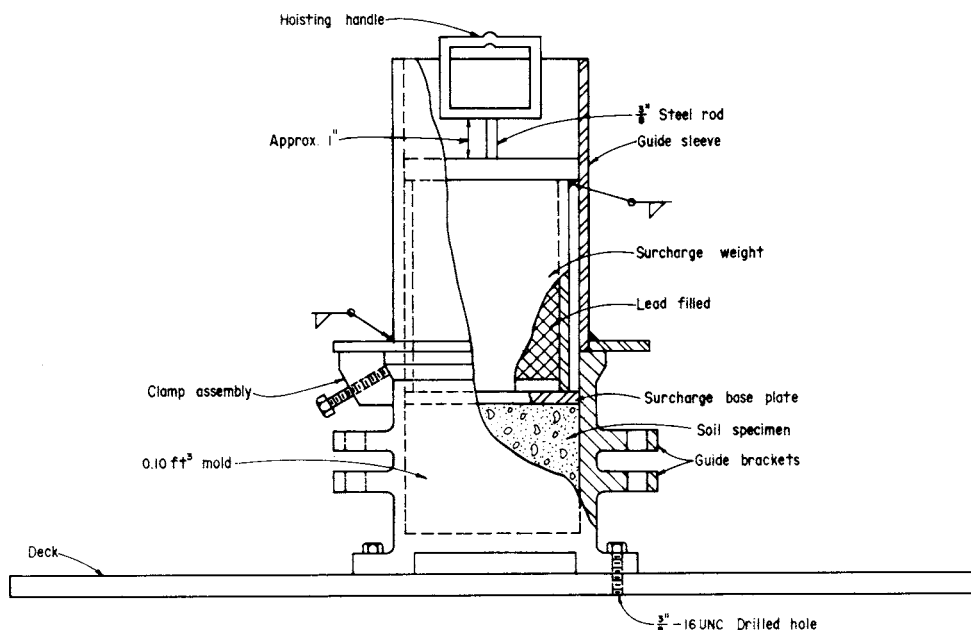

FIG. 1 Schematic Drawing of a Typical Mold Assembly

completion of densification. An example of such a handle is given in Fig. 4(b); however, any convenient hooking device may be used.

6.2 *Dial-Indicator Gage Holder and Dial Indicator*—A device used, in conjunction with the guide brackets, to measure the difference in elevation between the top surfaces of the mold and surcharge base plate after densification [Fig. 4(c)]. The dial indicator shall have a 2-in. (50-mm) or greater travel, with 0.001-in. (0.025-mm) graduations and mounted so that the dial stem is parallel with the vertical axis of the mold. The dial indicator may be of the clockwise-movement type where the dial pointer reads zero when the stem is extended, or of the counterclockwise type where the dial pointer reads zero when the stem is all the way in.

6.3 *Balance(s)*, of sufficient capacity to determine the total mass of the specimen and mold, having sufficient accuracy that the mass of the soil is determined to the nearest 0.1 %. Examples of balances capable of satisfying these requirements for most conditions have specifications as follows:

6.3.1 For 0.500-ft³ (14 200-cm³) molds, use a balance having a minimum capacity of 40-kg and meeting the requirements of Specification D 4753 for Class GP 10 (readability of 5 g).

6.3.2 For 0.100-ft³ (2 830-cm³) molds, use a balance of at least 15-kg capacity and meeting the requirements of Specification D 4753 for Class GP 5 (readability of 1 g).

6.3.3 For special molds that are less than 0.1-ft³ (2 830-cm³), use a balance having a minimum capacity of at least 2-kg and meeting the requirements of Specification D 4753 for a Class GP 2 (readability of 0.1 g).

6.4 *Hoist*—A rope, chain, or cable hoist of at least 140-kg capacity when either the 0.100-ft³ (2 830-cm³) or 0.500-ft³ (14 200 cm³) size molds are being used.

6.5 *Drying Oven*, thermostatically controlled, preferably of the forced-draft type, capable of maintaining a uniform temperature of 110 ± 5°C throughout the drying chamber.

6.6 *Sieves*, 3-in. (75-mm), 1½-in. (37.5-mm), ¾-in. (19-mm), ⅜-in. (9.5-mm), No. 4 (4.75-mm), and No. 200 (75-µm) sieves conforming to the requirements of Specifications E 11.

6.7 *Calibration Bar*, metal, about 3 by 12 by ¼ in. (75 by 300 by 6 mm), optional (see 10.4).

6.8 Other equipment such as mixing pans, a large metal scoop, a hair-bristled dusting brush, a timing device indicating minutes and seconds, a micrometer with at least a 1-in. (25-mm) travel and with 0.001-in. (0.025-mm) graduations, and a metal straight edge (for trimming excess soil after it has been placed in the mold, if the minimum index density/unit weight by Test Methods D 4254 is being determined).

6.9 *Vibrating Table*, shall be mounted to a concrete floor or mass of sufficient size and configuration that excess vibrations are not transmitted to other testing areas. The vertically vibrating deck of the table shall be of sufficient size and rigidity that the mold assembly being used can be attached and rigidly supported during the test. The table shall be capable of vertically vibrating the mold assembly with a sinusoid-like time-vertical displacement relationship at an average double amplitude (peak-to-peak displacement) of 0.013 ± 0.002 in. (0.33 ± 0.05 mm) at a frequency of 60 Hz or 0.019 ± 0.003 in. (0.48 ± 0.08 mm) at 50 Hz under test conditions. The table shall have the capability for adjustment of the frequency of vibration (between 0 to 60 Hz) or double amplitude of vibration, or both, between about 0.005 in. (0.15 mm) and 0.013 in. (0.33 mm) at 60 Hz or about 0.007 in. (0.20 mm) and 0.019 in. (0.48 mm) at 50 Hz for use with Methods 1A, 1B, 2A, or 2B (11.2.3). The table shall have the capability for adjustment of the double amplitude of vibration between about 0.008 in. (0.20 mm) and 0.025 in. (0.64 mm) at 60 Hz or about 0.012 in. (0.30 mm) and 0.036 in. (0.91 mm) at 50 Hz for use in conjunction with design or other special studies (11.1.6.3).

6.9.1 Use one of the following table types:

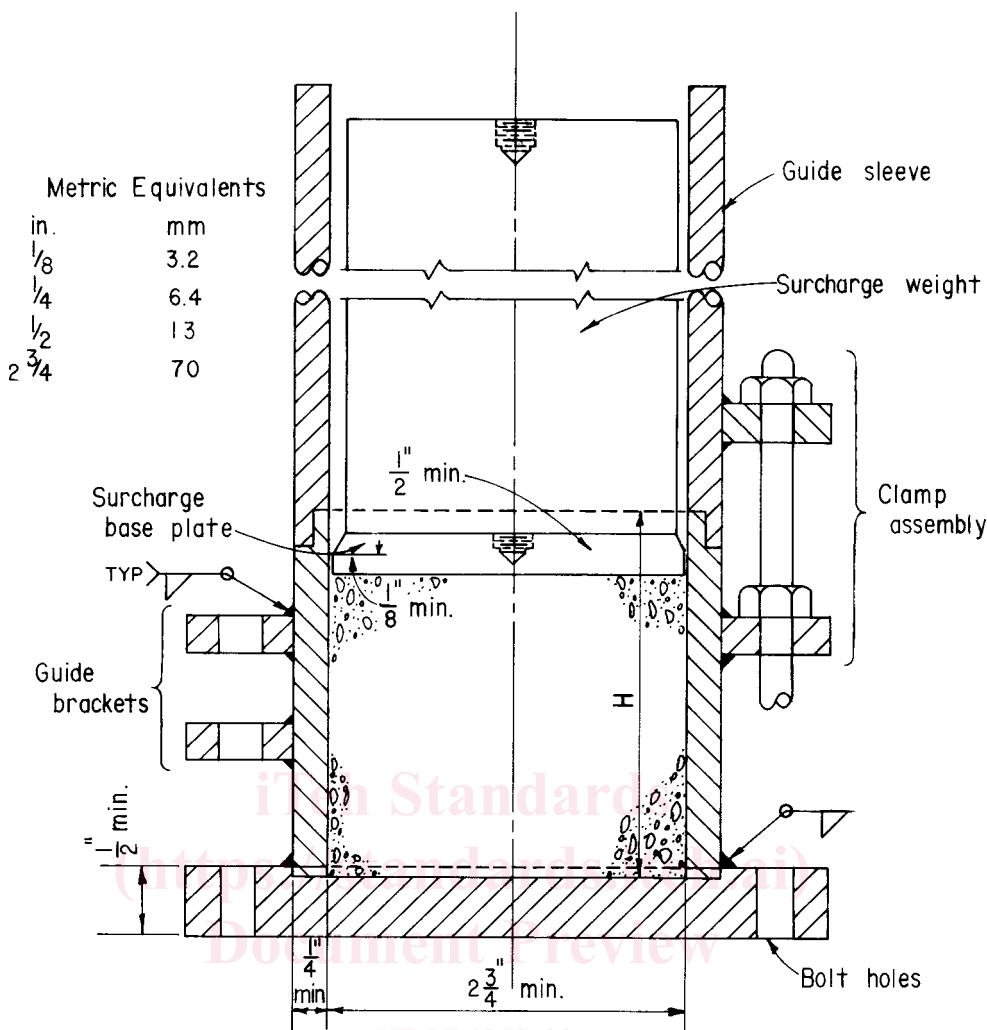

H = (0.7 to 1.3) times diameter
FIG. 3 Special Cylindrical Metal Molds

additional personal safety requirements in accordance with individual laboratory policies.

8. Sampling and Test Specimen

8.1 Prior to testing, the sample should be stored in a manner to prevent freezing, contamination with other matter, loss of soil, or loss of identification.

8.2 The required size (mass) of the test specimen and mold is a function of the maximum particle size contained in the sample and the particle-size distribution (gradation) of the sample (see Table 1).

8.2.1 Using a visual method or Test Method D 422 (depending upon the complexity of the gradation of the sample and operator experience), determine the percentage of particles retained on the 3-in. (75-mm), 1½-in. (37.5-mm), ¾-in. (19.0 mm), ⅜-in. (9.5-mm), No. 4 (4.75-mm), and No. 200 (75-µm) sieves.

8.2.2 The determination of the maximum index density/unit weight should not be performed in accordance with these test methods unless the requirements of 1.5 are met. If these conditions are met, then the mold size and specimen mass

required can be determined according to the maximum particle size as prescribed in Table 1.

8.2.3 When it is applicable to use special molds, 100 % of the sample shall pass the ¾-in. (19.0-mm) sieve and have less than 10 % retained on the ⅜-in. (9.5-mm) sieve.

8.2.3.1 The selected test specimen shall have a mass not less than that determined using the following equation:

$$M_r = 0.0024 \cdot V_m \tag{8}$$

where:

M_r = mass required in kg, and
 V_m = volume of mold in cm³.

8.3 Select a representative specimen of soil that meets the requirements of 8.2, using a splitter, riffle, or other method such as quartering.

8.4 If Methods 1A or 2A are being performed, dry the specimen in the drying oven, maintained at 110 ± 5°C to a constant mass. It is often desirable to obtain the water content of the field sample. If this is the case, determine the water content in accordance with Test Method D 2216.