



Designation: E 2558 – 07^{e1}

Standard Test Method for Determining Particulate Matter Emissions from Fires in Low Mass Wood-Burning Fireplaces¹

This standard is issued under the fixed designation E 2558; the number immediately following the designation indicates the year of original adoption or, in the case of revision, the year of last revision. A number in parentheses indicates the year of last reapproval. A superscript epsilon (ϵ) indicates an editorial change since the last revision or reapproval.

^{e1} NOTE—Editorial corrections made to 9.2.1 in May 2007.

1. Scope

1.1 This test method covers the fueling and operating protocol for determining particulate matter emissions from wood fires in low mass wood-burning fireplaces.

1.2 The values stated in SI units are to be regarded as the standard. The values given in parentheses are for information only.

1.3 *This standard does not purport to address all of the safety concerns, if any, associated with its use. It is the responsibility of the user of this standard to establish appropriate safety and health practices and determine the applicability of regulatory limitations prior to use.*

2. Referenced Documents

2.1 *ASTM Standards:*²

E 2515 Test Method for Determination of Particulate Matter Emissions Collected in a Dilution Tunnel

E 631 Terminology of Building Constructions

3. Terminology

3.1 Definitions—Terms used in this test method are defined in Terminology **E 631**.

3.2 Definitions of Terms Specific to This Standard:

3.2.1 *douglas fir, n*—untreated, standard, or better grade Douglas fir lumber with agency grade stamp: D. Fir or Douglas Fir.

3.2.2 *firebox, n*—the volume within the fireplace where logs are burned.

3.2.3 *first fuel crib, n*—the first fuel load (including fuel pieces and spacers to create air spaces) placed on the residual fuel from the kindling brands. The specific configuration is described in **9.3.1.4**.

3.2.4 *fuel piece, n*— 2×4 or 4×4 wood pieces used to construct fuel cribs and referring to the nominal width and depth dimensions for commonly available dimensional lumber. The actual dimensions are $38 \text{ mm} \times 89 \text{ mm}$ ($1 \frac{1}{2} \text{ in.} \times 3 \frac{1}{2} \text{ in.}$) and $89 \text{ mm} \times 89 \text{ mm}$ ($3 \frac{1}{2} \text{ in.} \times 3 \frac{1}{2} \text{ in.}$).

3.2.5 *grate, n*—any device included with the fireplace or specified by the fireplace manufacturer, for the purpose of elevating the fuel load above the hearth or for constraining fuel pieces from falling outside the intended burning area, or both. This includes basket grates and andirons.

3.2.6 *hearth, n*—the footprint of the fireplace firebox.

3.2.7 *kindling brands, n*—the initial fuel load or loads placed above crumpled newspaper to initiate combustion in the fireplace and to establish a charcoal bed that will become the ignition source for subsequent fuel loads. These are comprised of fuel strips separated by air spaces. The specific configuration is described in **9.3.4**.

3.2.8 *low mass fireplace, n*—any fireplace and attached chimney that can be weighed (including the weight of the test fuel) on a platform scale that meets the requirements as specified in **8.2**.

3.2.9 *nominal fuel length, n*—the Nominal Fuel Length (NFL) is one of five incremental nominal fuel piece lengths that simulates real-world firewood five piece lengths. These lengths are 406 mm (16 in.), 457 mm (18 in.), 508 mm (20 in.), 559 mm (22 in.), and 610 mm (24 in.). The NFL is used for both the kindling brands and fuel cribs.

3.2.10 *particulate matter (PM), n*—all gas-borne matter resulting from combustion of solid fuel, as specified in this test method, which is collected in accordance with Test Method **E 2515**.

3.2.11 *second fuel crib, n*—the second fuel load (including fuel pieces and spacers to create air spaces) placed on the residual fuel from the first fuel crib. The specific configuration is described in **9.3.4.5**.

3.2.12 *spacers, n*—wood pieces used to hold individual fuel pieces together when constructing the three fuel cribs. Their function is to provide reproducible fuel crib geometry and air spaces between fuel pieces, as well as to hold the fuel cribs together (with nails).

¹ This test method is under the jurisdiction of ASTM Committee E06 on Performance of Buildings and is the direct responsibility of Subcommittee E06.54 on Solid Fuel Burning Appliances.

Current edition approved April 1, 2007. Published May 2007.

² For referenced ASTM standards, visit the ASTM website, www.astm.org, or contact ASTM Customer Service at service@astm.org. For *Annual Book of ASTM Standards* volume information, refer to the standard's Document Summary page on the ASTM website.

3.2.13 *standardized fuel retainer, n*—any fireplace that doesn't include or specify a grate as defined in 3.2.11 shall use a standardized fuel retainer during testing. These retainers shall include vertical fuel retainer bars that are made from 19 mm × 19 mm (0.75 in. × 0.75 in.) steel square bar or 19 mm (0.75 in.) diameter round steel bar and shall be 200 mm ± 50 mm (8 in. ± 2 in.) high. They shall be attached to a steel plate that projects toward the front of the fireplace and shall not interfere with any fireplace function. They shall be spaced so they are 300 mm ± 13 mm (12 in. ± ½ in.) apart. Their purpose is to prevent fuel from rolling or falling forward during testing, thus helping to prevent an aborted test. See Fig. 1.

3.2.14 *test facility, n*—the area in which the tested fireplace is installed, operated, and sampled for emissions.

3.2.15 *third fuel crib, n*—the third and final fuel load (including fuel pieces and spacers to create air spaces) placed on the residual fuel from the second fuel crib. The specific configuration is described in 9.3.4.6.

4. Summary of Test Method

4.1 This test method is used in conjunction with Test Method E 2515. The fireplace under evaluation is fueled with kindling and cribs in a way that simulates fireplace operation in the home. An algorithm that uses the specific configuration of the test fireplace, including hearth and grate dimensions, is used to determine the kindling and fuel crib geometry and dimensions. Kindling brands are placed in the fireplace above crumpled newspaper and ignited. When the kindling brands have burned to a certain point, the first fuel crib is placed on the remains of the kindling. When the first crib is substantially burned, the remaining material is adjusted as needed to form a base for the second crib. This process is repeated again before addition of the third crib. The third crib is allowed to burn until all flaming from volatile material in the fuel ceases, at which point the test is terminated. Burn rate is determined based on the amount of fuel added less the amount remaining at the end of the test divided by the length of test and corrected to a dry fuel basis. Particulate sampling begins at the time of ignition of the newspaper and stops when the test terminates. The total particulate emissions are determined over the test period. The particulate emissions factor is then determined from the total

emissions and the total amount of fuel burned and is reported in grams of particulate per dry kilogram of fuel or grams of particulate per hour.

4.2 If the test fireplace includes standard (or offers optional) components that affect particulate emission performance and that have more than one operating position or condition allowed in the owner's manual that accompanies the fireplace, separate emissions tests may be required for each of the various positions or conditions that are allowed in the manual. This might include things like door open and door closed operation, for example. See 9.4.11-9.4.13.

5. Significance and Use

5.1 This test method is used for determining emission factors and emission rates for low mass wood-burning fireplaces.

5.1.1 The emission factor is useful for determining emission performance during product development.

5.1.2 The emission factor is useful for the air quality regulatory community for determining compliance with emission performance limits.

5.1.3 The emission rate may be useful for the air quality regulatory community for determining impacts on air quality from fireplaces, but must be used with caution as use patterns must be factored into any prediction of atmospheric particulate matter impacts from fireplaces based on results from this method.

5.2 The reporting units are grams of particulate per kilogram of dry fuel and grams of particulate per hour.

5.2.1 Appropriate reporting units for comparing emissions from non-heating appliances: g/kg.

5.2.2 Appropriate reporting units for predicting atmospheric emission impacts only if hours of fireplace use are factored in: g/hour.

6. Safety

6.1 *Disclaimer*—This test method may involve hazardous materials, operations, and equipment. This test method may not address all of the safety problems associated with its use. It is the responsibility of the user of this test method to establish

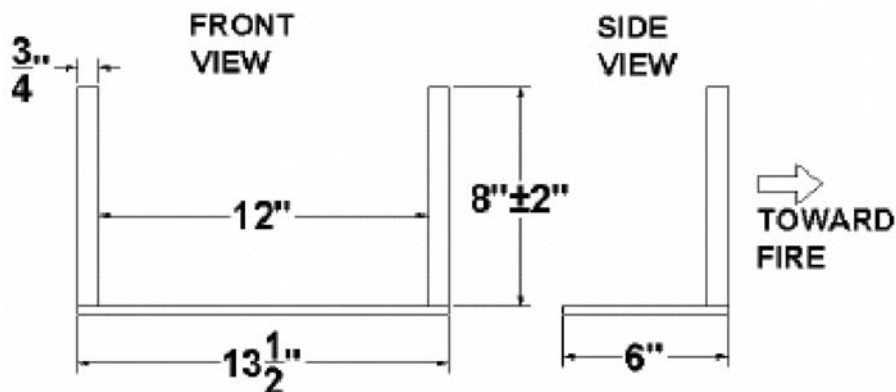

FIG. 1 Example, Standardized Fuel Retainer

appropriate safety and health practices and to determine the applicability of regulatory limitations prior to performing this test method.

7. Equipment and Supplies

7.1 *Wood Moisture Meter*—Calibrated electrical resistance meter capable of measuring test fuel moisture to within 1 % moisture content. Must meet the calibration requirements specified in 8.1.

7.2 *Test Fuel Scale*—A scale capable of weighing test fuel to within 0.05 kg (0.1 lb). Must meet the calibration requirements specified in 8.3.

7.3 *Platform Scale*—A scale capable of weighing the test fireplace and attached chimney, including the weight of the test fuel, to within 0.05 kg (0.1 lb). Must meet the calibration requirements specified in 8.2.

7.4 *Fireplace Flue Gas Temperature Measurement Device*—A 3.2 mm (0.125 in.) diameter sheathed, non-isolated junction Type K thermocouple capable of measuring flue gas temperature with an accuracy of 3°C (5.4°F). Must meet calibration requirements specified in 8.4.

7.5 *Fireplace Temperature Measuring Device*—A temperature sensor capable of measuring firebox surface temperatures with an accuracy of 3°C (5.4°F). Must meet calibration requirements specified in 8.4.

8. Calibration and Standardization

8.1 *Wood Moisture Meter*—Calibrate as per the manufacturer's instructions before each certification test.

8.2 *Platform Scale*—Perform a multi-point calibration (at least five points spanning the operational range) of the platform scale before its initial use. The scale manufacturer's calibration results are sufficient for this purpose. Before each certification test, audit the scale with the test fireplace in place by weighing at least one calibration weight (ASTM Class F) that corresponds to between 20 and 80 % of the expected test fuel charge weight. If the scale cannot reproduce the value of the calibration weight within 0.05 kg (0.1 lb) or 1 % of the expected test fuel charge weight, whichever is greater, recalibrate the scale before use with at least five calibration weights spanning the operational range of the scale.

8.3 *Test Fuel Scale*—Perform a multi-point calibration (at least five points spanning the operational range) of the test fuel scale before its initial use. The scale manufacturer's calibration results are sufficient for this purpose. Before each certification test, audit the scale with the wood heater in place by weighing at least one calibration weight (ASTM Class F) that corresponds to between 20 and 80 % of the expected test fuel charge weight. If the scale cannot reproduce the value of the calibration weight within 0.05 kg (0.1 lb) or 1 % of the expected test fuel charge weight, whichever is greater, recalibrate the scale before use with at least five calibration weights spanning the operational range of the scale.

8.4 *Temperature Sensors*—Temperature measuring equipment shall be calibrated before initial use and at least semi-annually thereafter. Calibrations shall be NIST traceable and demonstrate accuracy of $\pm 2^{\circ}\text{C}$ (3.6°F).

9. Procedure

9.1 *Pre-Conditioning of the Fireplace*—The fireplace to be evaluated must be burned for at least 10 h prior to testing for emissions. This may be done inside or outside the test facility.

9.1.1 Set up the fireplace in accordance with instructions provided by the manufacturer. The total height of chimney when measured from the floor or top of the platform scale shall be 4.6 m \pm 0.3 m (15 ft \pm 1 ft).

9.1.2 Install a flue-gas temperature measurement device at the center of the flue, 2.4 m \pm 0.1 m (8 ft \pm 0.3 ft) above the floor.

9.1.3 Record the start time and flue gas temperature.

9.1.4 Ignite a fire using newspaper and kindling and establish an actively burning fire. Add more fuel as needed to sustain the fire.

NOTE 1—Any type of untreated wood may be used for the pre-conditioning.

9.1.5 Record the time and weight for all fuel added.

9.1.6 Record the flue-gas temperature at least once during each 30 min of operation.

9.1.7 Record the ending time, total wood weight of wood burned, and total elapsed time of operation.

9.1.8 When the pre-conditioning fire is completed, allow the fireplace to cool to room temperature and remove all unburned wood, charcoal, ash, or other debris from the firebox.

9.1.9 Clean the chimney using a standard chimney brush appropriately sized for the chimney.

9.2 Install the fireplace in the test facility.

9.2.1 Set up the fireplace in accordance with instructions provided by the manufacturer. Use the chimney type supplied or specified by the manufacturer. The total height of chimney when measured from the top of the platform scale shall be 4.6 m \pm 0.3 m (15 ft \pm 1 ft). Do not install a chimney cap.

NOTE 2—The chimney that is used for testing should be documented in the test data and test report.

9.2.2 Center the flue outlet (chimney) under the dilution tunnel hood. Refer to Test Method E 2515 for specific requirements including positioning the flue outlet to meet induced draft and smoke capture requirements.

9.2.3 Install a flue-gas temperature measurement device at the center of the flue, 2.4 m \pm 0.1 m (8 ft \pm 0.3 ft) above the floor.

9.3 *Fuel*

9.3.1 *Fuel Properties*—

9.3.1.1 The fuel is untreated, standard, or better grade Douglas fir lumber.

9.3.1.2 *Fuel Moisture*—The fuel moisture shall be measured using a fuel moisture meter as specified in 7.1. Moisture shall not be added to previously dried fuel pieces. Fuel moisture shall be measured within four hours of using the fuel for a test.

(1) *Kindling Loads*—The average fuel moisture for each fuel strip used in each of the two specified kindling brands shall be between 6 and 12 % Dry Basis. Kiln-dried lumber is permitted for the kindling brands. Determine fuel moisture for each fuel strip. One moisture meter reading from each strip, measured parallel to the wood grain is sufficient. If an electrical resistance type fuel moisture meter is used, penetration of

insulated electrodes shall be ¼ the thickness of the fuel strips. Average all the readings for all the fuel strips for each kindling brand to determine the average fuel moisture for each kindling brand.

(2) *Main Fuel Cribs*—The average fuel moisture for each fuel piece used to construct each of the three fuel cribs shall be between 19 and 25 % Dry Basis. Kiln-dried lumber is not permitted. Kiln-dried lumber is permitted for the spacers. Determine the fuel moisture for each fuel piece (excluding spacers) used for each of the three fuel cribs by averaging at least three fuel moisture meter readings, one from each of three sides, measured parallel to the wood grain. If an electrical resistance type fuel moisture meter is used, penetration of insulated electrodes shall be ¼ the thickness of the fuel piece or 19 mm (¾ in.), whichever is greater. Average all the fuel piece readings to determine the average fuel moisture for each fuel crib.

9.3.1.3 *Fuel Density*—The average fuel density, dry basis, shall be in the range of 0.434 to 0.546 g/cm³ (27 to 34 lb/ft³) for each of the kindling brands and three fuel cribs.

9.3.1.4 *Nails*—Use uncoated, ungalvanized nails for assembling kindling brands and main fuel loads. In general, the number of nails used should be limited to the minimum number necessary to hold the kindling brands and fuel cribs together.

9.3.1.5 *Weight*—Record the total weight of each kindling brand or main fuel crib after it is assembled using the test fuel scale specified in 7.2. The weighed fuel brands and cribs must be used within 3 h of being weighed.

9.3.2 *Nominal Fuel Length*—The NFL for each fireplace being evaluated is determined based on dimensional parameters of the fireplace firebox or grate, or both.

9.3.2.1 If the fireplace includes a manufacturer supplied or specified grate (See Fig. 2), the NFL is:

(1) The longest of the five standard fuel lengths that will fit in or on the grate without interference from any part of the grate structure, or;

(2) If the grate does not include end log retainer bars that limit fuel length, the longest of the five standard fuel lengths that does not extend by more than 2 in. past the longest horizontal grate dimension when the fuel length is centered left-to-right on the grate, or;

(3) If the 2-in. extension of the fuel past the longest grate dimension causes interference with the walls of the firebox, the

longest of the standard fuel lengths that can be centered on the grate without interference from the firebox walls, or;

(4) If the manufacturer’s written instructions that accompany the fireplace include a specific fuel piece length recommendation for the fireplace user, the recommended length shall be used.

NOTE 3—If the manufacturer’s recommended length is not one of the five standard fuel lengths, use the closest standard fuel length that does not exceed the manufacturer’s recommended length.

9.3.2.2 If the fireplace has no grate supplied or specified by the manufacturer, the NFL is the longest fuel length that will fit without interference from side walls of the firebox, while still allowing the front edge of the first kindling crib to be no closer to the front of the fireplace opening than ⅓ the depth of the fireplace. See Fig. 3.

(1) Standardized fuel retainers shall be used for any fireplace that does not have a grate.

9.3.2.3 Dimensional tolerance for the NFL is ±1.5 mm (⅓ in.).

9.3.3 *Newspaper*

9.3.3.1 Loosely crumpled balls of full sheets of non-color ink newspaper are used to ignite the kindling loads. The number of balls is dependent on the NFL. The intent is to ensure rapid and even ignition of the kindling brands. The following guideline (Table 1) is given:

NFL		Newspaper # of Sheets
mm	inches	
406	16	4
457	18	5
508	20	6
559	22	7
610	24	8

9.3.4 *Kindling Loads*

9.3.4.1 The first kindling brand is comprised of two layers of 19 mm × 19 mm (¾ in. × ¾ in.) strips of Douglas fir that meet the specifications of 9.3.1. The strips are spaced 12.7 mm (½ in.) apart and nailed together. The two layers are perpendicular to each other. See Figs. 4 and 5.

(1) The bottom layer is comprised of strips that are 210 mm long (8 ¼ in.). The number of strips is dependent on the NFL as determined in 9.3.2.3. See Table 2.

(2) The top layer is comprised of seven strips. The top layer length (TLL) is determined by the NFL. See Table 2.

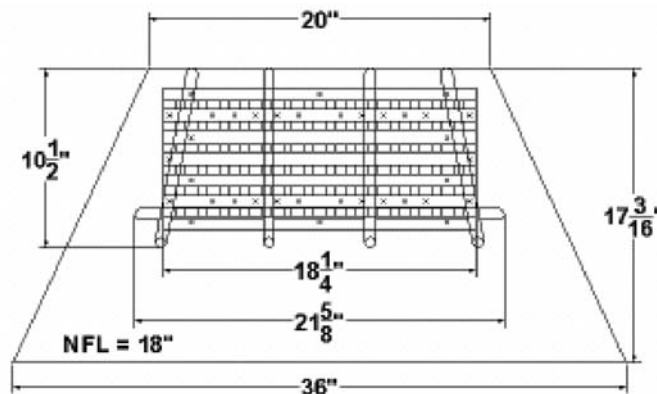

FIG. 2 NFL Example, Traditional, with Grate

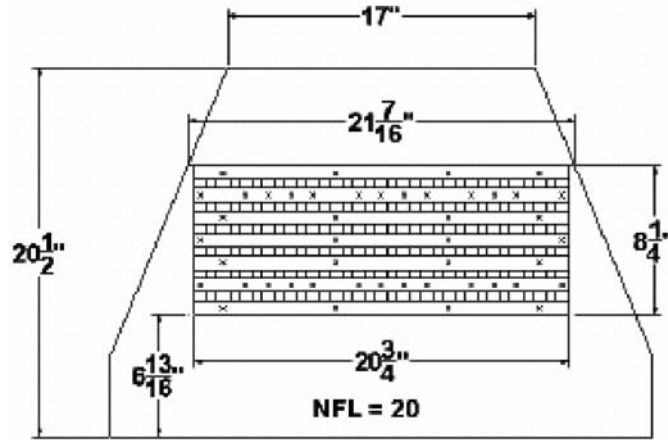

FIG. 3 NFL Example, Traditional, No Grate

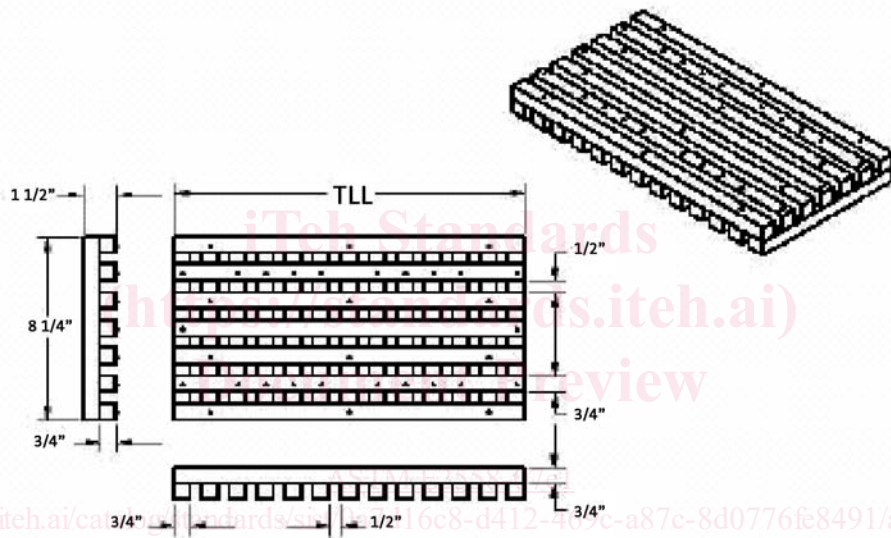

FIG. 4 Kindling Brand 1

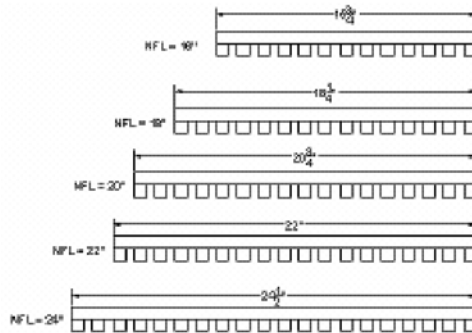

FIG. 5 Kindling Brand 1—Front View For Each NFL

9.3.4.2 The second kindling brand is comprised of two layers of Douglas fir that meet the specifications of 9.3.1. The fuel pieces are nailed together. The two layers are perpendicular to each other. See Fig. 6.

(1) The bottom layer is comprised of 38 mm × 38 mm (1 1/2 in. × 1 1/2 in.) pieces or a combination of 38 mm × 38 mm

(1 1/2 in. × 1 1/2 in.) and 19 mm × 38 mm (3/4 in. × 1 1/2 in.) pieces spaced 35 mm (1 3/8 in.) apart. Each piece is 210 mm (8 1/4 in.) long. The number and position of each strip is determined by the NFL. See Fig. 6 and Fig. 7 and Table 3.

(2) The top layer is comprised of four 19 mm × 19 mm (3/4 in. × 3/4 in.) strips. The outer strips are located at the ends of

TABLE 2 Kindling Brand 1

NFL		Lower Layer # of Strips	Top Layer Length	
mm	in.		mm	in.
406	16	13	400	15¾
457	18	15	464	18¼
508	20	17	527	20¾
559	22	18	559	22
610	24	20	622	24½

the lower layer pieces and the remaining two strips are spaced 38 mm (1½ in.) from the first two. The top layer length (TLL) is determined by the NFL. See Fig. 6 and Fig. 7 and Table 3.

9.3.4.3 Main Fuel Loads—There are three main fuel cribs that are added to the fire as described in 8.4. The cribs are comprised of dimensional lumber assembled in specific patterns with specific air spaces between the pieces. The dimensional lumber pieces are air-dried Douglas fir that meet the specifications of 9.3.1. The fuel spacer pieces are Douglas fir that meet the specifications of 9.3.1. All pieces are nailed together. See notes for each crib for suggestions on nailing.

9.3.4.4 First Fuel Crib—The first fuel crib is comprised of one fuel piece of 4 × 4 dimensional lumber and two fuel pieces of 2 × 4 dimensional lumber plus six spacers. The length of each fuel piece is the NFL as determined in 9.3.2.3. The 2 × 4 fuel pieces face the front of the fireplace and are offset from each other by 3 mm (⅛ in.). The crib is assembled using four 19 mm × 38 mm (¾ in. × 1½ in.) spacers and two 12.7 mm × 38 mm (½ in. × 1½ in.) spacers. See Fig. 8 for the specific details of construction.

9.3.4.5 Second Fuel Crib—The second fuel crib is comprised of two fuel pieces of 4 × 4 dimensional lumber and one fuel piece of 2 × 4 dimensional lumber plus two spacers. The length of each fuel piece is the NFL as determined in 9.3.2.3. The 2 × 4 fuel piece and one 4 × 4 fuel piece are nailed together with three 8-penny common nails to form a nominal 4 × 6 piece. The nails are centered on the width of the 89-mm face of the 2 × 4, with one nail at the center of the NFL and the other two spaced in 100 mm (4 in.) from each end. The crib is assembled using two 19 mm × 38 mm (¾ in. × 1½ in.) spacers so that the fuel pieces are rotated 45° from horizontal. The 4 × 4 faces the front of the fireplace. See Fig. 9 for the specific details of construction.

9.3.4.6 Third Fuel Crib—The third fuel crib is comprised of two fuel pieces of 2 × 4 dimensional lumber plus spacers. The length of each fuel piece is the NFL as determined in 9.3.2.3. The crib is assembled using six 12.7 mm × 38 mm (½ in. × 1½ in.) spacers. See Fig. 10 for the specific details of construction.

9.4 Operation

9.4.1 Prior to beginning a test, measure the temperature of the fireplace. Use a surface temperature probe held against the center of the back wall of the firebox until a constant temperature is obtained. The fireplace temperature must be within the allowable test facility temperature range specified in Test Method E 2515.

9.4.2 Within 10 min prior to starting the emissions test run, record the indicated scale weight of the empty fireplace/chimney assembly. If the test will be conducted using a standardized fuel retainer, include the weight of the fuel

retainer in the empty fireplace weight. Note: After obtaining the empty starting weight of the fireplace/chimney assembly, tare the platform scale to obtain a zero empty starting weight if that function is available on your scale.

9.4.3 Newspaper and Kindling (See Fig. 11)

9.4.3.1 Record the weight of and then place the appropriate number of crumpled newspaper balls as shown in 9.3.3 in the fireplace, such that they will be evenly distributed under the kindling brands.

9.4.3.2 Record the weight of and then place the first kindling brand above the newspaper balls. The short strips of fuel should be on the bottom, closest to the fireplace hearth.

(1) Locate the first kindling brand on the grate or on the hearth in accordance with the manufacturer's written instructions that are supplied with the fireplace, or if no written instructions are provided, see below.

(2) If the fireplace has a grate, center the first kindling brand on the grate, both front-to-back and left-to-right.

(3) If the fireplace does not have a grate, place the first kindling brand so that it is centered left-to-right and is as far back in the fireplace as possible. Without compressing the newspaper balls anymore than absolutely needed, nestle the first kindling brand so that it is as level as possible on the newspaper balls.

9.4.3.3 Record the weight of and then place the second kindling brand on top of the first. The short fuel pieces should be on the bottom, closest to the first kindling brand. Center the second kindling brand over the first, both front-to-back and left-to-right.

9.4.4 For fireplaces without grates, place the standardized fuel retainer so that the back surfaces of the vertical fuel retainer bars are within 13 mm (½ in.) of the front of the deepest of the three main fuel cribs (typically, this will be the second fuel crib). Center the standardized fuel retainer from left to right.

9.4.5 When all requirements for starting the emissions test are met in accordance with Test Method E 2515, record the start time, record the indicated scale weight of the fireplace including the combined weight of newspaper and first and second kindling brands or if the scale has been tared, record the combined weight of the newspaper and first and second kindling brands directly, start the sampling equipment, and then ignite the newspaper balls. A propane gas torch has been found to be a good device for obtaining rapid and even ignition of the newspaper. Quickly work your way from one side to the other to insure even ignition. All newspaper must be ignited within 30 s from starting the sampling equipment.

9.4.6 When the indicated scale weight is between 20 % and 15 % of the combined weight (wet) of the newspaper, first and second kindling brands, record the time and add the first fuel crib per the following procedure. See Fig. 12.

9.4.6.1 Using a poker, gently agitate the remains of the kindling brands to cause burning coals and fuel pieces to break apart and create a bed under the grate (if used) or on the hearth (if there is no grate). Poking should last no more than 60 s.

9.4.6.2 Level the remaining fuel to provide an even base for the first fuel crib.