



Designation: D5466 – 01(Reapproved 2007)

Standard Test Method for Determination of Volatile Organic Chemicals in Atmospheres (Canister Sampling Methodology)¹

This standard is issued under the fixed designation D5466; the number immediately following the designation indicates the year of original adoption or, in the case of revision, the year of last revision. A number in parentheses indicates the year of last reapproval. A superscript epsilon (ϵ) indicates an editorial change since the last revision or reapproval.

1. Scope

1.1 This test method describes a procedure for sampling and analysis of volatile organic compounds (VOCs) in ambient, indoor, or workplace atmospheres. The test method is based on the collection of air samples in stainless steel canisters with specially treated (passivated) interior surfaces. For sample analysis, a portion of the sample is subsequently removed from the canister and the collected VOCs are selectively concentrated by adsorption or condensation onto a trap, subsequently released by thermal desorption, separated by gas chromatography, and measured by a mass spectrometric detector or other detector(s). This test method describes procedures for sampling into canisters to final pressures both above and below atmospheric pressure (respectively referred to as pressurized and subatmospheric pressure sampling).²

1.2 This test method is applicable to specific VOCs that have been tested and determined to be stable when stored in canisters. Numerous compounds, many of which are chlorinated VOCs, have been successfully tested for storage stability in pressurized canisters (1-4).³ Although not as extensive, documentation is also available demonstrating stability of VOCs in subatmospheric pressure canisters. While initial studies were concentrated on non-polar VOCs, information on storage stability has been extended to many polar compounds as well (5-7).

1.3 The procedure for collecting the sample involves the use of inlet lines and air filters, flow rate regulators for obtaining time-integrated samples, and in the case of pressurized samples, an air pump. Canister samplers have been designed to automatically start and stop the sample collection process using electronically actuated valves and timers (8-10). A weather-proof shelter is required if the sampler is to be used outside.

¹ This test method is under the jurisdiction of ASTM Committee D22 on Air Quality and is the direct responsibility of Subcommittee D22.05 on Indoor Air.

Current edition approved April 1, 2007. Published June 2007. Originally approved in 1993. Last previous edition approved in 2001 as D5466 – 01. DOI: 10.1520/D5466-01R07.

² This test method is based on EPA Compendium Method TO-14, "The Determination of Volatile Organic Compounds (VOCs) in Ambient Air Using SUMMA Passivated Canister Sampling and Gas Chromatographic Analysis," May 1988.

³ The boldface numbers in parentheses refer to the list of references at the end of the standard.

1.4 The organic compounds that have been successfully measured at single-digit parts-per-billion by volume (ppbv) levels with this test method are listed in Table 1. This test method is applicable to VOC concentrations ranging from the detection limit to 300 ppbv. Above this concentration, samples require dilution with dry ultra-high-purity nitrogen or air.

1.5 *This standard does not purport to address all of the safety concerns, if any, associated with its use. It is the responsibility of the user of this standard to establish appropriate safety and health practices and determine the applicability of regulatory limitations prior to use. Safety practices should be part of the user's SOP manual.*

2. Referenced Documents

2.1 ASTM Standards:⁴

D1356 Terminology Relating to Sampling and Analysis of Atmospheres

D1357 Practice for Planning the Sampling of the Ambient Atmosphere

E260 Practice for Packed Column Gas Chromatography

E355 Practice for Gas Chromatography Terms and Relationships

2.2 Other Documents:

U.S. Environmental Protection Agency, Compendium of Methods for the Determination of Toxic Organic Compounds in Ambient Air, Method TO-14A, EPA 600/R-96/010b⁵

3. Terminology

3.1 *Definitions*—For definitions of terms used in this test method, refer to Terminology D1356. Other pertinent abbreviations and symbols are defined within this practice at point of use.

3.2 *Definitions of Terms Specific to This Standard:*

⁴ For referenced ASTM standards, visit the ASTM website, www.astm.org, or contact ASTM Customer Service at service@astm.org. For *Annual Book of ASTM Standards* volume information, refer to the standard's Document Summary page on the ASTM website.

⁵ Available from the U.S. Dept. of Commerce, National Technical Information Service, Port Royal Road, Springfield, VA 22161 or <http://www.cpa.gov/ttn/amtic/airtox.html>.

TABLE 1 Typical Volatile Organic Compounds Determined by the Canister Method

Compound (Synonym)	Formula	Molecular Weight	Boiling Point (°C)	Melting Point (°C)	CAS Number
Freon 12 (Dichlorodifluoromethane)	Cl ₂ CF ₂	120.91	-29.8	-158.0	
Methyl chloride (Chloromethane)	CH ₃ Cl	50.49	-24.2	-97.1	74-87-3
Freon 114 (1,2-Dichloro-1,1,2,2-tetrafluoroethane)	C ₂ Cl ₂ CF ₂	170.93	4.1	-94.0	
Vinyl chloride (Chloroethylene)	CH ₂ =CHCl	62.50	-13.4	-1538.0	75-01-4
Methyl bromide (Bromomethane)	CH ₃ Br	94.94	3.6	-93.6	74-83-9
Ethyl chloride (Chloroethane)	CH ₃ CH ₂ Cl	64.52	12.3	-136.4	75-00-3
Freon 11 (Trichlorofluoromethane)	CCl ₃ F	137.38	23.7	-111.0	
Vinylidene chloride (1,1-Dichloroethene)	C ₂ H ₂ Cl ₂	96.95	31.7	-122.5	75-35-4
Dichloromethane (Methylene chloride)	CH ₂ Cl ₂	84.94	39.8	-95.1	75-09-2
Freon 113 (1,1,2-Trichloro-1,2,2-trifluoroethane)	CF ₂ ClCCl ₂ F	187.38	47.7	-36.4	
1,1-Dichloroethane	CH ₃ CHCl ₂	98.96	57.3	-97.0	74-34-3
cis-1,2-Dichloroethylene	CHCl=CHCl	96.94	60.3	-80.5	
Chloroform (Trichloromethane)	CHCl ₃	119.38	61.7	-63.5	67-66-3
1,2-Dichloroethane (Ethylene dichloride)	C ₂ H ₄ Cl ₂	98.96	83.5	-35.3	107-06-2
Methyl chloroform (1,1,1-Trichloroethane)	CH ₃ CCl ₃	133.41	74.1	-30.4	71-55-6
Benzene	C ₆ H ₆	78.12	80.1	5.5	71-43-2
Carbon tetrachloride (Tetrachloromethane)	CCl ₄	153.82	76.5	-23.0	56-23-5
1,2-Dichloropropane (Propylene dichloride)	CH ₃ CHClCH ₂ Cl	112.99	96.4	-100.4	78-87-5
Trichloroethylene (Trichloroethene)	C ₂ HCl=CCl ₂	131.29	87	-73.0	79-01-6
cis-1,3-Dichloropropene (cis-1,3-dichloropropylene)	CH ₃ CC=CHCl	110.97	76		
trans-1,3-Dichloropropene (trans-1,3-Dichloropropylene)	C ₃ H ₃ Cl ₂	110.97	112.0		
1,1,2-Trichloroethane (Vinyl trichloride)	CH ₂ ClCHCl ₂	133.41	113.8	-36.5	79-00-5
Toluene (Methyl benzene)	C ₆ H ₅ CH ₃	92.15	110.6	-95.0	108-88-3
1,2-Dibromoethane (Ethylene dibromide)	BrCH ₂ CH ₂ Br	187.88	131.3	9.8	106-93-4
Tetrachloroethylene (Perchloroethylene)	C ₂ Cl ₄	165.83	121.1	-19.0	127-18-4
Chlorobenzene	C ₆ H ₅ Cl	112.56	132.0	-45.6	108-90-7
Ethylbenzene	C ₆ H ₅ C ₂ H ₅	106.17	136.2	-95.0	100-41-4
m-Xylene (1,3-Dimethylbenzene)	1,3-(CH ₃) ₂ C ₆ H ₄	106.17	139.1	-47.9	
p-Xylene (1,4-Dimethylxylene)	1,4-(CH ₃) ₂ C ₆ H ₄	106.17	138.3	13.3	
Styrene (Vinyl benzene)	C ₆ H ₅ CH=CH ₂	104.16	145.2	-30.6	100-42-5
1,1,2,2-Tetrachloroethane	CHCl ₂ CHCl ₂	167.85	146.2	-36.0	79-34-5
o-Xylene (1,2-Dimethylbenzene)	1,2-(CH ₃) ₂ C ₆ H ₄	106.17	144.4	-25.2	
1,3,5-Trimethylbenzene (Mesitylene)	1,3,5-(CH ₃) ₃ C ₆ H ₃	120.20	164.7	-44.7	108-67-8
1,2,4-Trimethylbenzene	1,2,4-(CH ₃) ₃ C ₆ H ₃	120.20	169.3	-43.8	95-63-6
m-Dichlorobenzene (1,3-Dichlorobenzene)	1,3-C ₂ H ₄ Cl ₂	147.01	173.0	-24.7	541-73-1
Benzyl chloride (α-Chlorotoluene)	C ₆ H ₅ CH ₂ Cl	126.59	179.3	-39.0	100-44-7
o-Dichlorobenzene (1,2-Dichlorobenzene)	1,2-C ₂ H ₄ Cl ₂	147.01	180.5	-17.0	95-50-1
p-Dichlorobenzene (1,4-Dichlorobenzene)	1,4-C ₂ H ₄ Cl ₂	147.01	174.0	53.1	106-46-7
1,1,2,3,4,4-Hexachloro-1,3-butadiene	Cl ₆ C ₄	260.76	215	-21.0	7-68-3

ASTM D5466-01(2007)

3.2.1 *absolute canister pressure*— $P_g + P_a$, where P_g = gage pressure in the canister. (kPa, psi) and P_a = barometric pressure.

3.2.2 *absolute pressure*—pressure measured with reference to absolute zero pressure (as opposed to atmospheric pressure), usually expressed as kPa, mm Hg, or psia.

3.2.3 *certification*—the process of demonstrating with humid zero air and humid calibration gases that the sampling systems components and the canister will not change the concentrations of sampled and stored atmospheres.

3.2.4 *cryogen*—a refrigerant used to obtain very low temperatures in the cryogenic trap of the analytical system. A typical cryogen is liquid argon (bp -185.7°C) or liquid nitrogen (bp -195°C).

3.2.5 *dynamic calibration*—calibration of an analytical system using calibration gas standard concentrations generated by diluting known concentration compressed gas standards with purified, humidified inert gas.

3.2.5.1 *Discussion*—Such standards are in a form identical or very similar to the samples to be analyzed. Calibration standards are introduced into the inlet of the sampling or analytical system in the same manner as authentic field samples.

3.2.6 *gage pressure*—pressure measured above ambient atmospheric pressure (as opposed to absolute pressure). Zero gage pressure is equal to ambient atmospheric (barometric) pressure.

3.2.7 *megabore column*—chromatographic column having an internal diameter (I.D.) greater than 0.50 mm.

3.2.7.1 *Discussion*—The Megabore column is a trademark of the J & W Scientific Co. For purposes of this test method, Megabore refers to chromatographic columns with 0.53 mm I.D.

3.2.8 *MS-SCAN*—the GC is coupled to a Mass Spectrometer (MS) programmed to scan all ions over a preset range repeatedly during the GC run.

3.2.8.1 *Discussion*—As used in the current context, this procedure serves as a qualitative identification and characterization of the sample.

3.2.9 *MS-SIM*—the GC is coupled to a MS programmed to acquire data for only specified ions and to disregard all others. This is performed using selected ion monitoring (SIM) coupled to retention time discriminators. The GC-SIM analysis provides quantitative results for selected constituents of the sample gas as programmed by the user.

3.2.10 *pressurized sampling*—collection of an air sample in a canister with a (final) canister pressure above atmospheric pressure, using a sample pump.

3.2.11 *qualitative accuracy*—the ability of an analytical system to correctly identify compounds.

3.2.12 *quantitative accuracy*—the ability of an analytical system to correctly measure the concentration of an identified compound.

3.2.13 *static calibration*—calibration of an analytical system using standards in a form different than the samples to be analyzed.

3.2.13.1 *Discussion*—An example of a static calibration would be injecting a small volume of a high concentration standard directly onto a GC column, bypassing the sample extraction and preconcentration portion of the analytical system.

3.2.14 *subatmospheric sampling*—collection of an air sample in an evacuated canister to a (final) canister pressure below atmospheric pressure, with or without the assistance of a sampling pump.

3.2.14.1 *Discussion*—The canister is filled as the internal canister pressure increases to ambient or near ambient pressure. An auxiliary vacuum pump may be used as part of the sampling system to flush the inlet tubing prior to or during sample collection.

4. Summary of Test Method

4.1 The method described is taken from published work (1-22) and is the basis of EPA Compendium Method TO-14A. It has been used since the early 1980s in studies to establish long term trends in certain atmospheric gases (11), to determine the prevalence and extent of VOC contributions to ozone production (12), and to assess the toxicity of VOCs in the ambient air (13, 14).

4.2 Both subatmospheric pressure and pressurized sampling modes use an evacuated canister. A sampling line less than 2 % of the volume of the canister or a pump-ventilated sample line are used during sample collection. Pressurized sampling requires an additional pump to provide positive pressure to the sample canister. A sample of air is drawn through a sampling train comprising components that regulate the rate and duration of sampling into a precleaned and pre-evacuated passivated canister.

4.3 After the air sample is collected, the canister isolation valve is closed, the canister is removed from the sampler, an identification tag is attached to the canister, and the canister is transported to a laboratory for analysis.

4.4 Upon receipt at the laboratory, the data on the canister tag are recorded and the canister is attached to a pressure gage which will allow accurate measurement of the final canister pressure. During analysis, water vapor may be reduced in the gas stream by a permeable membrane dryer (if applicable), and the VOCs are then concentrated by collection on a sorbent trap or in a cryogenically-cooled trap. The temperature of the trap is raised and the VOCs originally collected in the trap are revolatilized, separated on a GC column, and then detected by

TABLE 2 Ion/Abundance and Expected Retention Time for Selected VOCs Analyzed by GC-MS-SIM

Compound	Ion/ Abundance (amu/% base peak)	Expected Retention Time (min)
Freon 12 (Dichlorodifluoromethane)	85/100	5.01
	87/31	
Methyl chloride (Chloromethane)	50/100	5.69
	52/34	
Freon 114 (1,2-Dichloro-1,1,2,2-tetrafluoroethane)	85/100	6.55
	135/56	
	87/33	
Vinyl chloride (Chloroethene)	62/100	6.71
	27/125	
	64/32	
Methyl bromide (Bromomethane)	94/100	7.83
	96/85	
Ethyl chloride (Chloroethane)	64/100	8.43
	29/140	
	27/140	
Freon 11 (Trichlorofluoromethane)	101/100	9.97
	103/67	
Vinylidene chloride (1,1-Dichloroethylene)	61/100	10.93
	96/55	
	63/31	
Dichloromethane (Methylene chloride)	49/100	11.21
	84/65	
	86/45	
Freon 113 (1,1,2-Trichloro-1,2,2-trifluoroethane)	151/100	11.60
	101/140	
	103/90	
1,1-Dichloroethane	63/100	12.50
	27/64	
	65/33	
cis-1,2-Dichloroethylene	61/100	13.40
	96/60	
	98/44	
Chloroform (Trichloromethane)	83/100	13.75
	85/65	
	47/35	
1,2-Dichloroethane (Ethylene dichloride)	62/100	14.39
	27/70	
	64/31	
Methyl chloroform (1,1,1-Trichloroethane)	97/100	14.62
	99/64	
	61/61	
Benzene	78/100	15.04
	77/25	
	50/35	
Carbon tetrachloride (Tetrachloromethane)	117/100	15.18
	119/97	
1,2-Dichloropropane (Propylene dichloride)	63/100	15.83
	41/90	
	62/70	
Trichloroethylene (Trichloroethene)	130/100	16.10
	132/92	
	95/87	
cis-1,3-Dichloropropene	75/100	16.96
	39/70	
	77/30	
trans-1,3-Dichloropropene	75/100	17.49
	39/70	
	77/30	
1,1,2-Trichloroethane (Vinyl trichloride)	97/100	17.61
	83/90	
	61/82	
Toluene (Methyl benzene)	91/100	17.86
	92/57	
1,2-Dibromoethane (Ethylene dibromide)	107/100	18.48
	109/96	
	27/115	
Tetrachloroethylene (Perchloroethylene)	166/100	19.01
	164/74	
	131/60	
Chlorobenzene	112/100	19.73
	77/62	

TABLE 2 *Continued*

Compound	Ion/ Abundance (amu/% base peak)	Expected Retention Time (min)
Ethylbenzene	114/32 91/100	20.20
m,p-Xylene (1,3/1,4-dimethylbenzene)	106/28 91/100	20.41
Styrene (Vinyl benzene)	106/40 104/100	20.81
1,1,2,2-Tetrachloroethane	78/60 103/49	20.92
o-Xylene (1,2-Dimethylbenzene)	83/100 85/64	20.92
4-Ethyltoluene	91/100 106/40	22.53
1,3,5-Trimethylbenzene (Mesitylene)	105/100 120/42	22.65
1,2,4-Trimethylbenzene	105/100 120/42	23.18
m-Dichlorobenzene (1,3-Dichlorobenzene)	146/100 148/65	23.31
Benzyl chloride (α -Chlorotoluene)	111/40 91/100	23.32
p-Dichlorobenzene (1,4-Dichlorobenzene)	126/26 146/100	23.41
o-Dichlorobenzene (1,2-Dichlorobenzene)	148/65 111/40	23.88
1,2,4-Trichlorobenzene	146/100 148/65 111/40	26.71
Hexachlorobutadiene (1,1,2,3,4,4-Hexachloro-1,3-butadiene)	180/100 182/98 184/30	27.68
	225/100 227/66 223/60	

a mass spectrometer. Compound identification and quantitation are performed with this test method.

4.5 The VOCs are thermally desorbed from the trap into a small volume of carrier gas, separated by gas chromatography, and measured by a mass spectrometric detector or other detector(s) such as the flame ionization detector (FID) or electron capture detector (ECD). The analytical procedure can be automated (15-17) or manual (18). A procedure for measuring total FID response to a sample without gas chromatographic separation is also documented (19).

4.6 A mass spectrometric detector (MS coupled to a GC) is the principal analytical tool used for qualitative and quantitative analysis because it allows positive compound identification. MS detectors include, but are not limited to, magnetic sector mass analyzers, quadrupole mass filters, combined magnetic sector-electrostatic sector mass analyzers, time-of-flight mass analyzers and ion trap mass spectrometers.

4.6.1 Comparison of GC/MS–Full Scan and GC/MS–SIM:

4.6.1.1 GC/MS–Full Scan:

- (1) Positive nontarget compound identification possible,
- (2) Less sensitivity than GC/MS–SIM,
- (3) Greater sample volume may be required compared to SIM,
- (4) Resolution of co-eluting interfering ions is possible,
- (5) Positive compound identification,

(6) Quantitative determination of compounds on calibration list, and

(7) Qualitative and semiquantitative determination of compounds not contained on calibration list.

4.6.1.2 GC/MS–SIM:

- (1) Can't identify non-target compounds,
- (2) Less operator interpretation, and
- (3) Higher sensitivity than GC/MS–full scan.

4.6.2 The GC/MS–full scan option uses a capillary column GC coupled to a MS operated in a scanning mode and supported by spectral library search routines. This option offers the nearest approximation to unambiguous identification and covers a wide range of compounds as defined by the completeness of the spectral library. GC/MS–SIM mode is limited to a set of target compounds which are user defined and is more sensitive than GC/MS–SCAN by virtue of the longer dwell times at the restricted number of m/z values. As the number of ions monitored simultaneously in a GC/MS–SIM analysis increases, the sensitivity of this technique approaches GC/MS–SCAN. The practical limit for GC/MS–SIM is reached at about 4 to 5 ions monitored simultaneously.

5. Significance and Use

5.1 VOCs are emitted into the ambient, indoor, and workplace atmosphere from a variety of sources. In addition to the emissions from the use of various products, appliances, and building materials, fugitive or direct emissions from ambient sources such as manufacturing processes further complicate air composition. Many of these VOC compounds are acute or chronic toxins. Therefore, their determination in air is necessary to assess human health impacts.

5.2 The use of canisters is particularly well suited for the collection and analysis of very volatile, stable compounds in atmosphere (for example, vinyl chloride). This test method collects and analyzes whole gas samples and is not subject to high volatility limitations.

5.3 VOCs can be successfully collected in passivated stainless steel canisters. Collection of atmospheric samples in canisters provides for: (1) convenient integration of air samples over a specific time period (for example, 8 to 24 h), (2) remote sampling and central laboratory analysis, (3) ease of storing and shipping samples, (4) unattended sample collection, (5) analysis of samples from multiple sites with one analytical system, (6) dilution or additional sample concentration to keep the sample size introduced into the analytical instrument within the calibration range, (7) collection of sufficient sample volume to allow assessment of measurement precision or analysis, or both, of samples by several analytical systems, and (8) sample collection in remote access areas using a vacuum regulator flow controller if electricity is not available.

5.4 Interior surfaces of the canisters are treated by any of several proprietary passivation processes including an electropolishing process to remove or cover reactive metal sites on the interior surface of the vessel and a fused silica coating process.

5.5 This test method can be applied to sampling and analysis of compounds that can be quantitatively recovered from the canisters. The typical range of VOC applicable to this

test method are ones having saturated vapor pressures at 25°C greater than 15 Pa (10^{-1} mm Hg).

5.6 Recovery and stability studies must be conducted on any compound not listed in **Table 1** before expanding the use of this test method to additional compounds.

6. Interferences and Limitations

6.1 Water management is a significant analytical problem because VOC preconcentrators typically accumulate water vapor as well as VOCs, especially those preconcentrators that use reduced temperature condensation. The water can restrict and even stop the sample air flow, alter retention times, and affect the operation of detector systems, especially the mass spectrometric systems. In-line permeable membrane dryers are frequently used prior to preconcentration and do not produce artifacts for a number of compounds including those that are on the target list for this method provided certain precautions are observed (**20, 21**). Release of an air sample from a pressurized canister that contains humid air will result in a systematic increase in the humidity of the released sample air as long as condensed water remains on the canister interior (**22**).

6.2 For those applications where a membrane dryer is used, interferences can occur in sample analysis if moisture accumulates in the dryer (see **10.1.1.3**). An automated cleanup procedure that periodically heats the dryer to about 100°C while purging with zero air eliminates any moisture buildup. This procedure does not degrade sample integrity.

NOTE 1—Removing moisture from samples is not necessary with GC/MS systems that are differentially pumped and which do not employ membrane drying apparatus.

6.3 Contamination may occur in the sampling system if canisters are not properly cleaned before use. Additionally, all other sampling equipment (for example, pump and flow controllers) must be thoroughly cleaned to ensure that the filling apparatus will not contaminate samples. Instructions for cleaning the canisters and certifying the field sampling system are described in **11.1** and **11.2**, respectively. In addition, sufficient system and field blank samples shall be analyzed to detect contamination as soon as it occurs.

6.4 If the GC/MS analytical system employs a permeable membrane dryer or equivalent to remove water vapor selectively from the sample stream, polar organic compounds will permeate this membrane concurrently with the moisture. Consequently, the analyst must calibrate his or her system with the specific organic constituents under examination. For quantitative analysis of polar compounds analytical systems may not employ permeable membrane dryers.

7. Apparatus

7.1 Stainless steel canisters with interior surfaces passivated by either electropolishing or silica coating, available from various commercial sources.

7.2 Subatmospheric pressure and pressurized canister sampling systems are commercially available and have been evaluated for VOC testing in air (**8-10**). Several configurations of standard hardware can be used successfully as canister sampling units.

7.2.1 *Subatmospheric Pressure* (see **Fig. 1**).

7.2.1.1 *Inlet Line*, Stainless steel tubing to connect the sampler to the sample inlet.

7.2.1.2 *Canister*, leak-free stainless steel pressure vessels of desired volume (for example, 6 L), with valve and passivated interior surfaces.

7.2.1.3 *Vacuum/Pressure Gage*, capable of measuring vacuum (–100 to 0 kPa or 0 to 30 in Hg) and pressure (0 to 200 kPa or 0 to 30 psig) in the sampling system. Gages shall be tested clean and leak tight.

7.2.1.4 *Mass Flow Meter and Controller*, capable of maintaining a constant flow rate ($\pm 10\%$) over a sampling period of up to 24 h and under conditions of changing temperature (20 to 40°C) and humidity.

7.2.1.5 *Filter*, 7- μ m sintered stainless-steel in-line filter.

7.2.1.6 *Electronic Timer*, capable of activating a solenoid valve (see **7.2.1.7**) to start and stop flow entering a canister, that is, for unattended sample collection.

7.2.1.7 *Solenoid Valve*, electrically operated, bi-stable solenoid valve with fluoroelastomer seat and o-rings, or low temperature solenoid valve.

7.2.1.8 *Tubing and Fittings*, chromatographic grade stainless steel tubing and fittings for interconnections. All such materials in contact with sample, analyte, and support gases prior to analysis shall be chromatographic grade stainless steel.

7.2.1.9 *Heater*, thermostatically controlled to maintain temperature inside insulated sampler enclosure above ambient temperature if needed.

7.2.1.10 *Fan*, for cooling sampling system, if needed.

7.2.1.11 *Thermostat*, automatically regulates fan operation, if needed.

7.2.1.12 *Maximum-Minimum Thermometer*, records highest and lowest temperatures during sampling period.

7.2.1.13 *Shut-Off Valve*, stainless steel—leak free, for vacuum/pressure gage.

7.2.1.14 *Auxiliary Vacuum Pump (optional)*, continuously draws air to be sampled through the inlet manifold at 10 L/min or higher flow rate. Sample is extracted from the manifold at a lower rate, and excess air is exhausted. The use of higher inlet

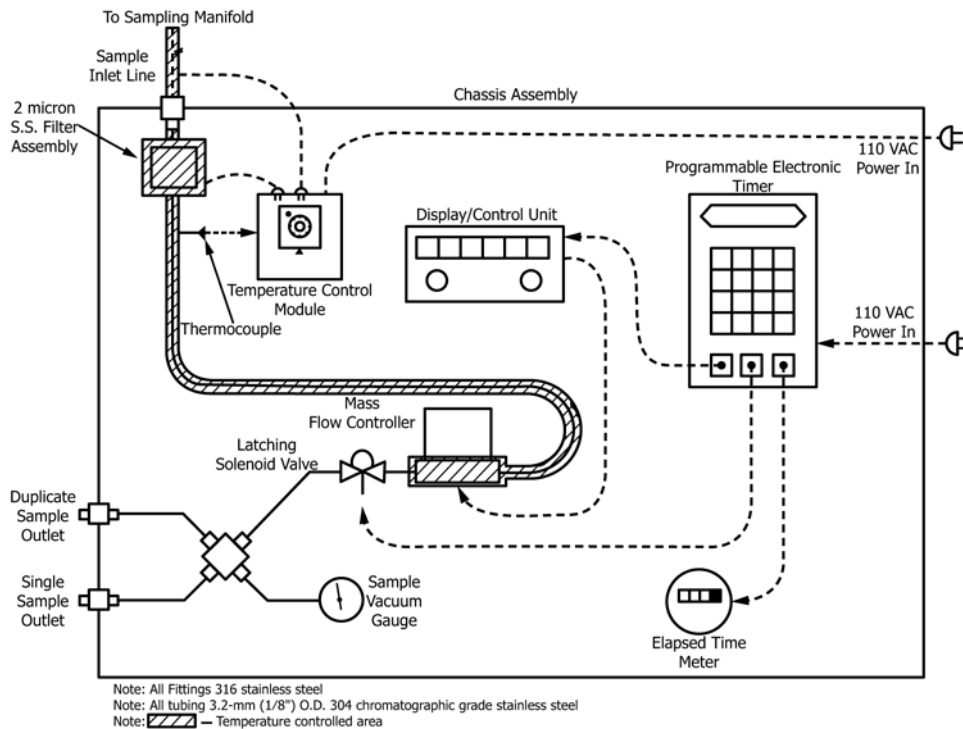

FIG. 1 Sampler Configuration For Subatmospheric Pressure Canister Sampling

flow rates dilutes any contamination present in the inlet and reduces the possibility of sample contamination as a result of contact with active adsorption sites on inlet walls. Pump is not necessary if the intake manifold represents less than 5 % of the final sample.

7.2.1.15 *Elapsed Time Meter*, capable of measuring the duration of sampling to the nearest second.

7.2.1.16 *Optional Fixed Orifice, Capillary, Adjustable Micrometering Valve, or Vacuum Regulator*, may be used in lieu of the electronic flow controller for grab samples or short duration time-integrated samples. Such systems require manual activation and deactivation. In this standard, application of a pumpless simple orifice sampler is appropriate only in situations where samples consume 60 % or less of the total capacity of the canister used for collection. Typically this limits the sample duration to a maximum of 8 h per 6 L canister or 20 h per 15 L canister.

7.2.2 *Pressurized*, see Fig. 1 and Fig. 2.

7.2.2.1 *Sample Pump*, stainless steel pump head, metal bellows type capable of 200 kPa output pressure. Pump must be free of leaks, clean, and uncontaminated by oil or organic compounds.

NOTE 2—Several sampling systems have been developed that result in pressurizing a canister with sample air. The system illustrated in Fig. 2 uses an auxiliary vacuum pump to flush the sample inlet. A non-contaminating air pump pulls air from the inlet tubing, through a critical orifice which regulates the flow, and into the canisters.

7.2.2.2 *Other Supporting Materials*, all other components of the pressurized sampling system are similar to components discussed in 7.2.1.1 – 7.2.1.16.

7.3 Sample Analysis Equipment:

7.3.1 GC/MS-Analytical System (Full Scan and SIM).

7.3.1.1 The GC/MS-SCAN analytical system must be capable of acquiring and processing data in the MS–full scan mode. The GC/MS-SIM analytical system must be capable of acquiring and processing data in the MS-SIM mode.

7.3.1.2 *Gas Chromatograph*, capable of sub-ambient temperature programming for the oven, with other standard features such as gas flow regulators, automatic control of valves and integrator, etc. Flame ionization detector optional.

7.3.1.3 *Chromatographic Detector*, mass spectrometric detector equipped with computer and appropriate software. The GC/MS is set in the SCAN mode, where the MS screens the sample for identification and quantitation of VOC species.

7.3.1.4 *Cryogenic Trap with Temperature Control Assembly*, refer to 10.1.1.4 for complete description of trap and temperature control assembly. Traps may be built into the gas chromatograph by the manufacturer or added to existing units.

7.3.1.5 *Electronic Mass Flow Controllers (3)*, to maintain constant flow for carrier gas and sample gas and to provide analog output to monitor flow anomalies.

7.3.1.6 *Vacuum Pump*, general purpose laboratory pump, capable of evacuating a known volume reservoir (which will be used for sample transfer) or for drawing the desired sample volume through the cryogenic trap.

7.3.1.7 *Chromatographic Grade Stainless Steel Tubing and Stainless Steel Plumbing Fittings*, refer to 7.2.1.8 for description.

7.3.1.8 *Chromatographic Column*(see Table 3), to provide compound separation.

NOTE 3—Other columns (6 % cyanopropylphenyl/94 % dimethylpolysiloxane) can be used as long as the system meets user needs. The wider megabore column (that is, 0.53 mm I.D.) is less susceptible to plugging as a result of trapped water, thus eliminating the need for a permeable

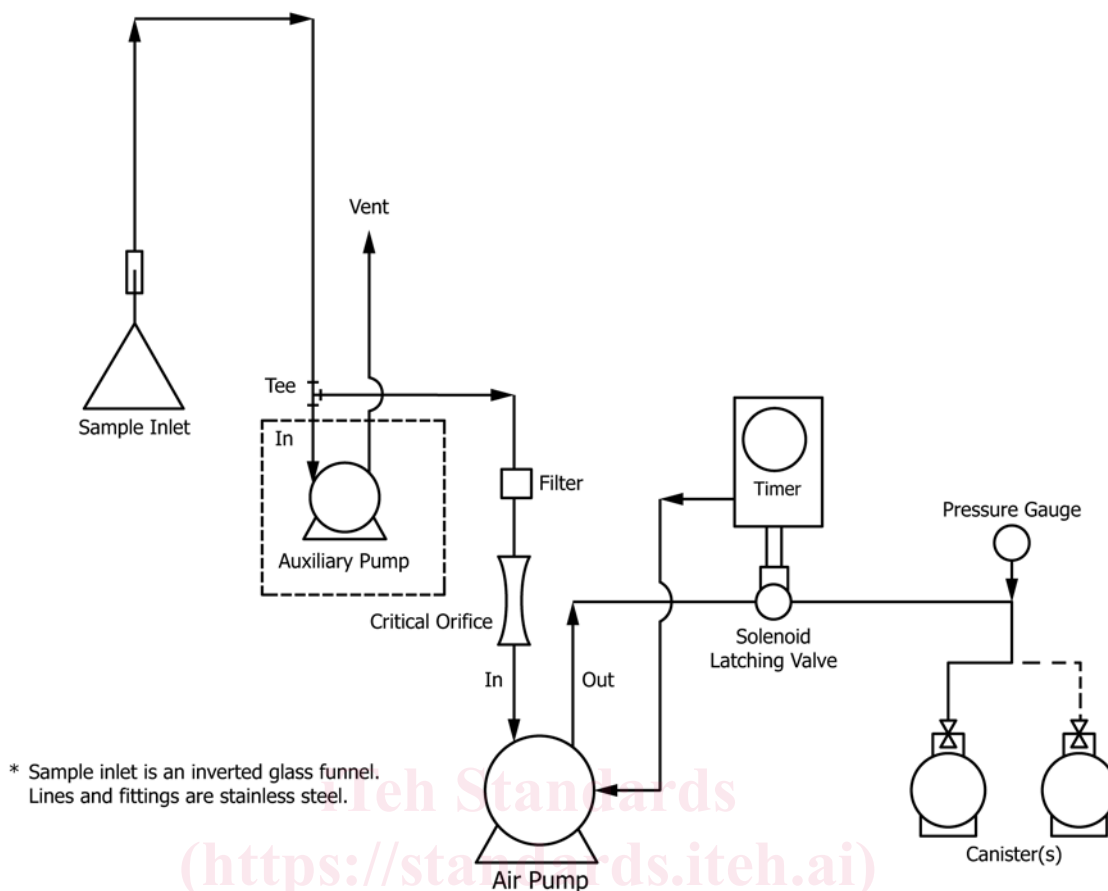

FIG. 2 Alternative Sampler Configuration for Pressurized Canister Sampling

membrane dryer in the analytical system. The megabore column has sample capacity approaching that of a packed column, while retaining much of the peak resolution traits of narrower columns (that is, 0.32 mm I.D.).

7.3.1.9 *Stainless Steel Vacuum/Pressure Gage (optional)*, capable of measuring vacuum (–100 to 0 kPa) and pressure (0–200 kPa) in the sampling system. Gages shall be tested clean and leak tight.

7.3.1.10 *Cylinder Pressure Stainless Steel Regulators*, standard, two-stage cylinder regulators with pressure gages for helium, zero air, nitrogen, and hydrogen gas cylinders.

7.3.1.11 *Gas Purifiers (4)*, molecular sieve or carbon used to remove organic impurities and moisture from gas streams.

7.3.1.12 *Low Dead-Volume Tee or Press Fit Splitter (optional)*, used to split the exit flow from the GC column.

7.3.1.13 *Dryer (optional)*, consisting of permeable membrane tubing coaxially mounted within larger tubing, available commercially. Refer to 10.1.1.3 for description.

7.3.1.14 *Six-Port Gas Chromatographic Valve*.

7.4 *Canister Cleaning System (see Fig. 3):*

7.4.1 *Vacuum Pump*, capable of evacuating sample canister(s) to an absolute pressure of less than 0.0064 kPa (0.05 mm Hg).

7.4.2 *Manifold*, made of stainless steel with connections for simultaneously cleaning several canisters.

7.4.3 *Shut-Off Valve(s)*, on-off toggle valves.

7.4.4 *Stainless Steel Vacuum Gage*, capable of measuring vacuum in the manifold to an absolute pressure of 0.0064 kPa (0.05 mm Hg) or less.

7.4.5 *Cryogenic Trap (2 required)*, made of stainless steel U-shaped open tubular trap cooled with liquid nitrogen, for air purification purposes to prevent contamination from back diffusion of oil from vacuum pump and to provide clean, zero air to sample canister(s).

7.4.6 *Stainless Steel Pressure Gages (2)*, 0 to 350 kPa (0 to 50 psig) to monitor zero air pressure.

7.4.7 *Stainless Steel Flow Control Valve*, to regulate flow of zero air into canister(s).

7.4.8 *Humidifier*, consisting of Pressurizable Water Bubbler, (typically a passivated canister equipped with dip tube and dual valves). Humidifier contains high performance liquid chromatography (HPLC) grade deionized water.

7.4.9 *Isothermal Oven (optional)*, for heating canisters.

NOTE 4—Oven temperature must not exceed the manufacturer's recommendation during cleaning to avoid degradation of the passivated canister surface on repeated cleaning.

7.5 *Calibration System and Manifold (see Fig. 4):*

7.5.1 *Calibration Manifold*, chromatographic grade stainless steel or glass manifold (125 mm I.D. by 660 mm), with sampling ports and internal mixing for flow disturbance to ensure proper mixing.

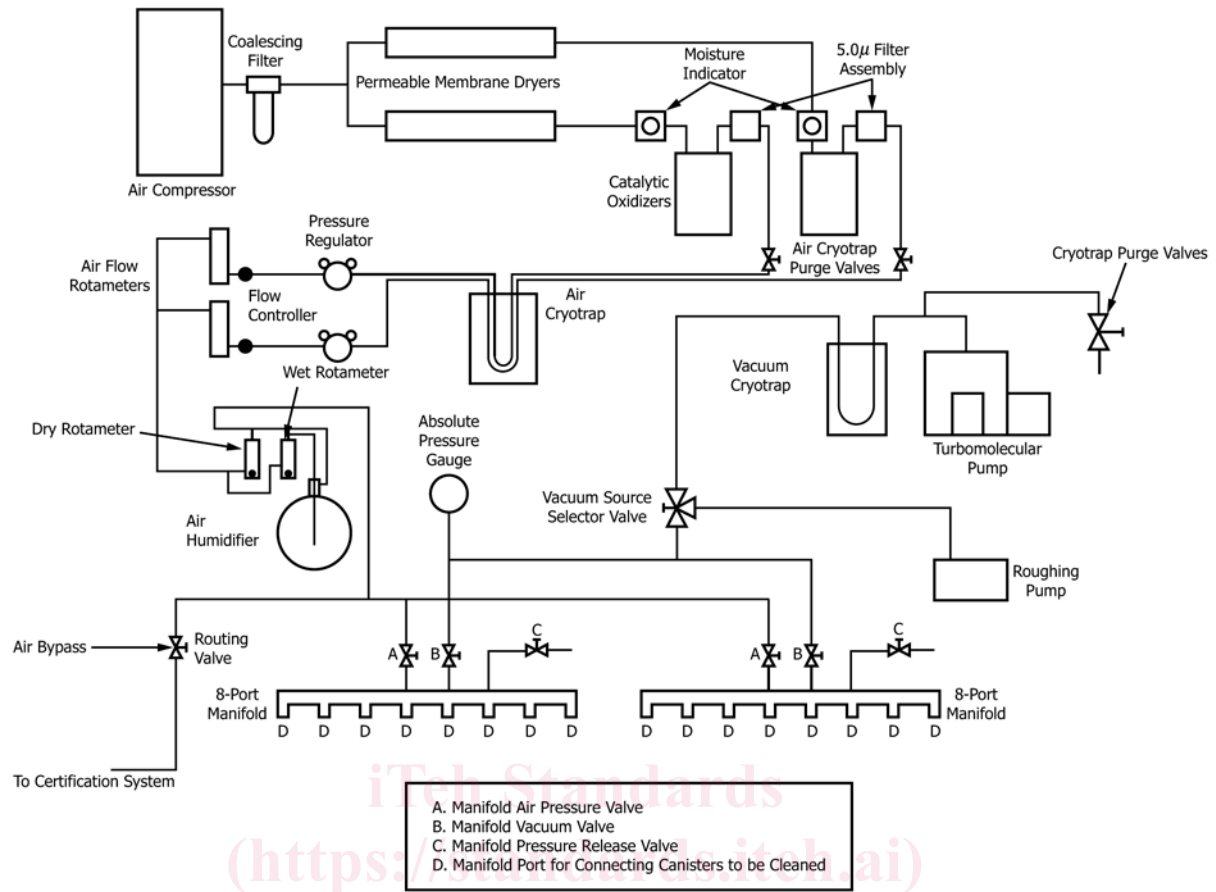

FIG. 3 Canister Cleanup Apparatus

TABLE 3 General GC and MS Operating Conditions

Chromatography	
Column	50-m × 0.32-mm I.D. crosslinked 100 % dimethylpolysiloxane (17 µm film thickness)
Carrier Gas	Helium (2.0 cm ³ /min at 250°C)
Injection Volume	Constant (1–3 µL)
Injection Mode	Splitless
Temperature Program	
Initial Column Temperature	–50°C
Initial Hold Time	2 min
Program	8°C/min to 150°C
Final Hold Time	15 min
Mass Spectrometer	
Mass Range	18 to 250 amu
Scan Time	1 s/scan
EI Condition	70 eV
Mass Scan	Follow manufacturer's instruction for selecting mass selective detector (MS) and selected ion monitoring (SIM) mode
Detector Mode	Multiple ion detection
FID System (Optional)	
Hydrogen Flow	30 cm ³ /min
Carrier Flow	30 cm ³ /min
Burner Air	400 cm ³ /min

8. Reagents and Materials

8.1 Gas cylinders of helium, hydrogen, nitrogen, and zero air ultrahigh purity grade.

8.2 Gas calibration standards—cylinder(s) containing approximately 10 ppmv of each of the following compounds of interest:

vinyl chloride	1,2-dibromoethane
vinylidene chloride	tetrachloroethylene
1,1,2-trichloro-1,2,2-trifluoroethane	chlorobenzene
p-dichlorobenzene	benzyl chloride
chloroform	hexachloro-1,3-butadiene
1,2-dichloroethane	methyl chloroform
benzene	carbon tetrachloride
toluene	trichloroethylene
dichlorodifluoromethane	cis-1,3-dichloropropene
methyl chloride	trans-1,3-dichloropropene
ethylbenzene	1,2-dichloro-1,1,2,2-tetrafluoroethane
1,2,4-trichlorobenzene	o-dichlorobenzene
methyl bromide	o-xylene
ethyl chloride	m-xylene
fluorotrichloromethane	p-xylene
dichloromethane	styrene
1,1-dichloroethane	1,1,2,2-tetrachloroethane
cis-1,2-dichloroethylene	1,3,5-trimethylbenzene
1,2-dichloropropane	1,2,4-trimethylbenzene
1,1,2-trichloroethane	m-dichlorobenzene

8.2.1 The cylinder(s) shall be traceable to a National Institute of Standards and Technology (NIST) Standard Reference Material (SRM) or to a NIST/EPA approved Certified Reference Material (CRM). The components may be purchased in one cylinder or may be separated into different cylinders. Refer

7.5.2 *Humidifier*, 500-mL impinger flask containing HPLC grade deionized water.

7.5.3 *Electronic Mass Flow Controllers*, one 0 to 5 L/min and one 0 to 50 mL/min.

7.5.4 *TFE-Fluorocarbon Filter(s)*, 47-mm TFE-Fluorocarbon filter for particulate control.

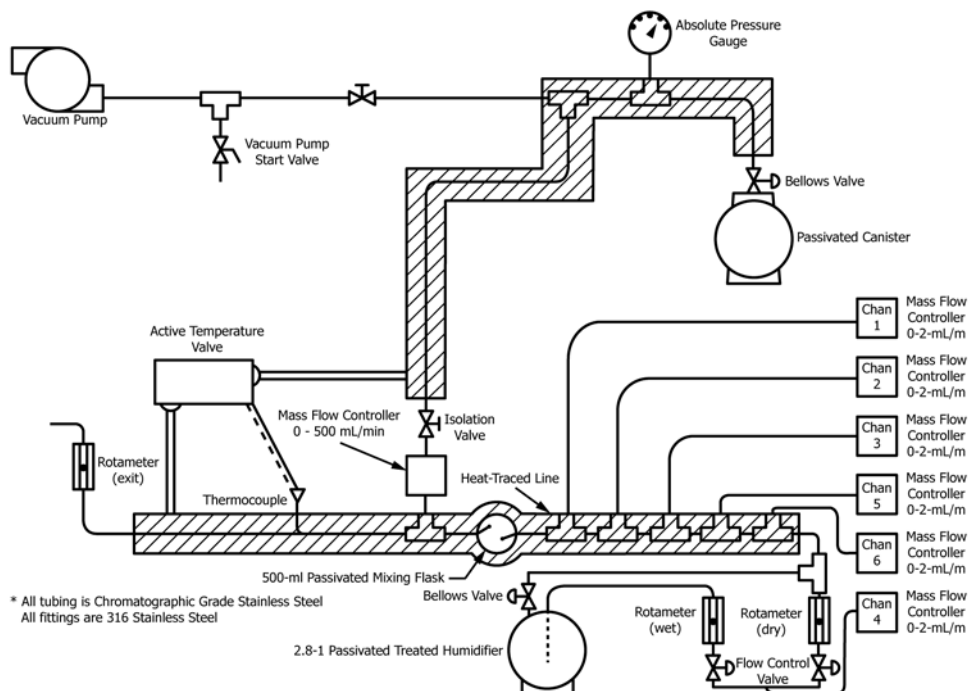

FIG. 4 Schematic of Calibration System and Manifold for (a) Analytical System Calibration, (b) Testing Canister Sampling System and (c) Preparing Canister Transfer Standards

to manufacturer's specification for guidance on purchasing and mixing VOCs in gas cylinders. Those compounds purchased should match one's own target list.

8.3 *Liquid Nitrogen* ($bp -195.8^{\circ}C$), used only for clean air traps and GC oven coolant, and sample concentration traps requiring active control to maintain $-185.7^{\circ}C$.

8.4 *Liquid Argon* ($bp -185.7^{\circ}C$), for sample traps that are not actively controlled to $-185.7^{\circ}C$.

8.5 *Gas Purifiers*—Molecular sieve or carbon, connected in-line between hydrogen, nitrogen, and zero air gas cylinders and system inlet line, to remove moisture and organic impurities from gas streams.

8.6 *Deionized Water*—High performance liquid chromatography (HPLC) grade, ultrahigh purity (for humidifier).

8.7 *4-Bromofluorobenzene*—Used for tuning GC/MS.

8.8 *Methanol*—For cleaning sampling system components, reagent grade.

9. Sampling System

9.1 System Description:

9.1.1 *Subatmospheric Pressure Sampling*—See Fig. 1 or Fig. 2.

9.1.1.1 In preparation for subatmospheric sample collection in a canister, the canister is evacuated to 0.0064 kPa (0.05 mm Hg) or less. When opened to the atmosphere containing the VOCs to be sampled, the differential pressure causes the sample to flow into the canister. This technique may be used to collect grab samples (duration of 10 to 30 s) or time-integrated samples (duration of 12 to 24 h) taken through a flow-

restrictive inlet (for example, mass flow controller, vacuum regulator, or critical orifice).

9.1.1.2 With a critical orifice flow restrictor, there will be a decrease in the flow rate if the pressure approaches atmospheric. However, with a mass flow controller the subatmospheric sampling system can be increased since the restrictor size can be adjusted. For example, an electronic flow controller with a flow rate range of 0 to 50 cc/min can maintain a constant (less than 5 % change) flow rate of 5 cc/min from full vacuum to within 7 kPa (1.0 psi) below ambient pressure.

9.1.2 *Pressurized Sampling*—See Fig. 1.

9.1.2.1 Pressurized sampling is used when longer-term integrated samples or higher volume samples are required. The sample is collected in a canister using a pump and flow control arrangement to achieve a typical 100–200 kPa (15–30 psig) final canister pressure. For example, a 6-L evacuated canister can be filled at 7.1 mL/min for 24 h to achieve a final pressure of about 67 kPa (10.5 psig).

NOTE 5—Collection of pressurized samples in humid environments may result in condensation of water in sampling canisters. The presence of condensed water may decrease the recovery of polar compounds from the canister and change the retention times of target compounds on the GC column.

9.1.2.2 In pressurized canister sampling, a metal bellows type pump draws in air from the sampling manifold to fill and pressurize the sample canister.

9.1.3 *All Samplers:*

9.1.3.1 A flow control device is chosen to maintain a constant flow into the canister over the desired sample period. This flow rate is determined so the canister is filled (to about 88.1 kPa for subatmospheric pressure sampling or to about one

atmosphere above ambient pressure for pressurized sampling) over the desired sample period. The flow rate can be calculated by:

$$F = (P \times V)/(t \times 60) \quad (1)$$

where:

- F = flow rate, mL/min,
- P = final canister pressure, atmospheres absolute. P is approximately equal to [(kPa gage)/100] + 1,
- V = volume of the canister, mL, and
- t = sample period, h.

9.1.3.2 For example, if a 6-L canister is to be filled to 200 kPa (2 atmospheres) absolute pressure in 24 h, the flow rate can be calculated by:

$$F = (2 \times 6000)/(24 \times 60) = 8.3 \text{ mL/min} \quad (2)$$

9.1.3.3 For automatic operation, the timer is wired to start and stop the pump at appropriate times for the desired sample

period. The timer must also control the solenoid valve, to open the valve when starting the pump and close the valve when stopping the pump.

9.1.3.4 The use of a latching solenoid, or low temperature valve, avoids any substantial temperature rise occurring with a conventional, normally energized solenoid during the entire sample period. The temperature rise in the valve could cause outgassing of organic compounds from the valve seat material which must be avoided to reduce background. The latch solenoid valve requires an electronic timer that can be programmed for short (5 to 60 s) "on" periods. Simple electrical pulse circuits for operating latching valves with a conventional mechanical timer are illustrated in Fig. 5.

9.1.3.5 The connecting lines between the sample inlet and the canister shall be as short as possible to minimize their volume. The flow rate into the canister shall remain relatively constant over the entire sampling period (see 9.1.1.2).

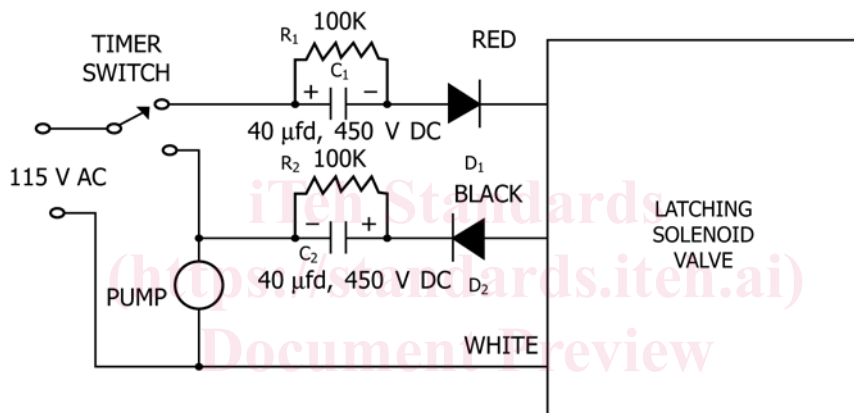

- A** COMPONENTS
 Capacitor C₁ and C₂ - 40 uf, 450 VDC
 Resistor R₁ and R₂ - 0.5 watt, 5% tolerance
 Diode D₁ and D₂ - 1000 PRV, 2.5 A

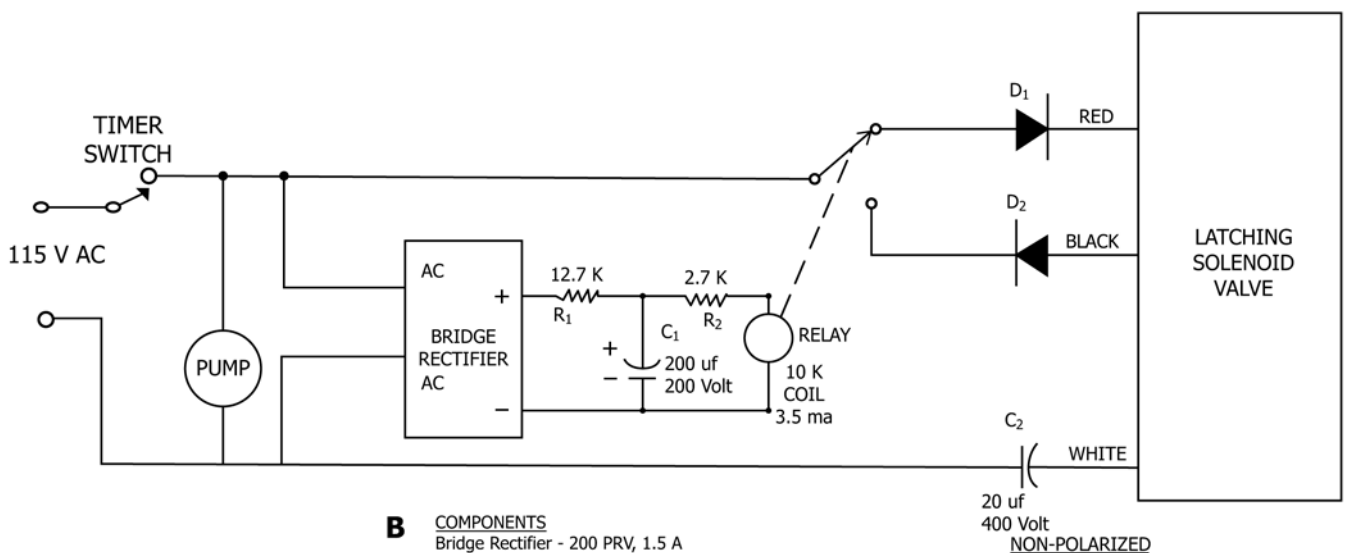

- B** COMPONENTS
 Bridge Rectifier - 200 PRV, 1.5 A
 Diode D₁ and D₂ - 1000 PRV, 2.5 A
 Capacitor C₁ - 200 uf, 250 VDC
 Capacitor C₂ - 20 uf, 400 VDC Non-Polarized
 Relay - 10,000 ohm coil, 3.5 ma
 Resistor R₁ and R₂ - 0.5 watt, 5% tolerance

FIG. 5 Electrical Pulse Circuits for Driving a Latching Solenoid Valve with a Mechanical Timer