



Designation: D5835 – 95(Reapproved 2007)

Standard Practice for Sampling Stationary Source Emissions for the Automated Determination of Gas Concentrations¹

This standard is issued under the fixed designation D5835; the number immediately following the designation indicates the year of original adoption or, in the case of revision, the year of last revision. A number in parentheses indicates the year of last reapproval. A superscript epsilon (ϵ) indicates an editorial change since the last revision or reapproval.

1. Scope

1.1 This practice² covers procedures and equipment that will permit, within certain limits, representative sampling for the automated determination of gas concentrations of effluent gas streams. The application is limited to the determination of oxygen (O_2), carbon dioxide (CO_2), carbon monoxide (CO), sulfur dioxide (SO_2), nitric oxide (NO), nitrogen dioxide (NO_2) and total oxides of nitrogen (NO_x).

1.2 Velocity measurements are required to determine the mass flow rates of gases. This is not included in this practice.

1.3 There are some combustion processes and situations that may limit the applicability of this practice. Where such conditions exist, caution and competent technical judgment are required, especially when dealing with any of the following:

- 1.3.1 Corrosive or highly reactive components,
- 1.3.2 High vacuum, high pressure, or high temperature gas streams,
- 1.3.3 Wet flue gases,
- 1.3.4 Fluctuations in velocity, temperature, or concentration due to uncontrollable variation in the process,
- 1.3.5 Gas stratification due to the non-mixing of gas streams,
- 1.3.6 Measurements made using environmental control devices, and
- 1.3.7 Low levels of gas concentrations.

1.4 *This standard does not purport to address all of the safety concerns, if any, associated with its use. It is the responsibility of the user of this standard to establish appropriate safety and health practices and determine the applicability of regulatory limitations prior to use.* For more specific safety precautions, refer to 5.1.4.8, 5.2.1.6, and 6.2.2.1.

¹ This practice is under the jurisdiction of ASTM Committee D22 on Air Quality and is the direct responsibility of Subcommittee D22.03 on Ambient Atmospheres and Source Emissions.

Current edition approved April 1, 2007. Published June 2007. Originally approved in 1995. Last previous edition approved in 2001 as D5835 - 95(2001). DOI: 10.1520/D5835-95R07.

² This practice is based on ISO 10396, "Stationary source emissions—Sampling for the automated determination of gas concentrations," available from International Organization for Standardization, Casa Postale 56, CH-1211, Geneva, Switzerland.

2. Referenced Documents

2.1 *ASTM Standards*:³

D1356 Terminology Relating to Sampling and Analysis of Atmospheres

D1608 Test Method for Oxides of Nitrogen in Gaseous Combustion Products (Phenol-Disulfonic Acid Procedures)

D3154 Test Method for Average Velocity in a Duct (Pitot Tube Method)

2.2 *Other Document*:

40 CFR Part 60, Standards of Performance for Stationary Sources, Appendix A, Test Methods 2, 3, 3a, 6, 6c, 7, 7e, and 10⁴

3. Terminology

3.1 *Definitions*:

3.1.1 For definitions of terms used in this practice, refer to Terminology D1356.

4. Summary of Practice

4.1 This practice describes representative sampling of gases in a duct, including both extractive and non-extractive sampling. In extractive sampling, these gases are conditioned to remove aerosols, particulate matter, and other interfering substances before being conveyed to the instruments. In non-extractive sampling, the measurements are made in-situ; therefore, no sample conditioning except filtering is required.

4.1.1 *Extractive Sampling*—Extractive sampling includes extraction of the sample, removal of interfering materials, and maintenance of the gas concentration throughout the sampling system for subsequent analysis by appropriate instrumentation (see Fig. 1).

4.2 *Non-extractive Sampling*—Non-extractive sampling does not involve removal of a sample, and sampling is confined to the gas stream in the stack or duct (see Figs. 2 and 3).

³ For referenced ASTM standards, visit the ASTM website, www.astm.org, or contact ASTM Customer Service at service@astm.org. For *Annual Book of ASTM Standards* volume information, refer to the standard's Document Summary page on the ASTM website.

⁴ Available from Supt. of Documents, U.S. Government Printing Office, Washington, DC 20402.

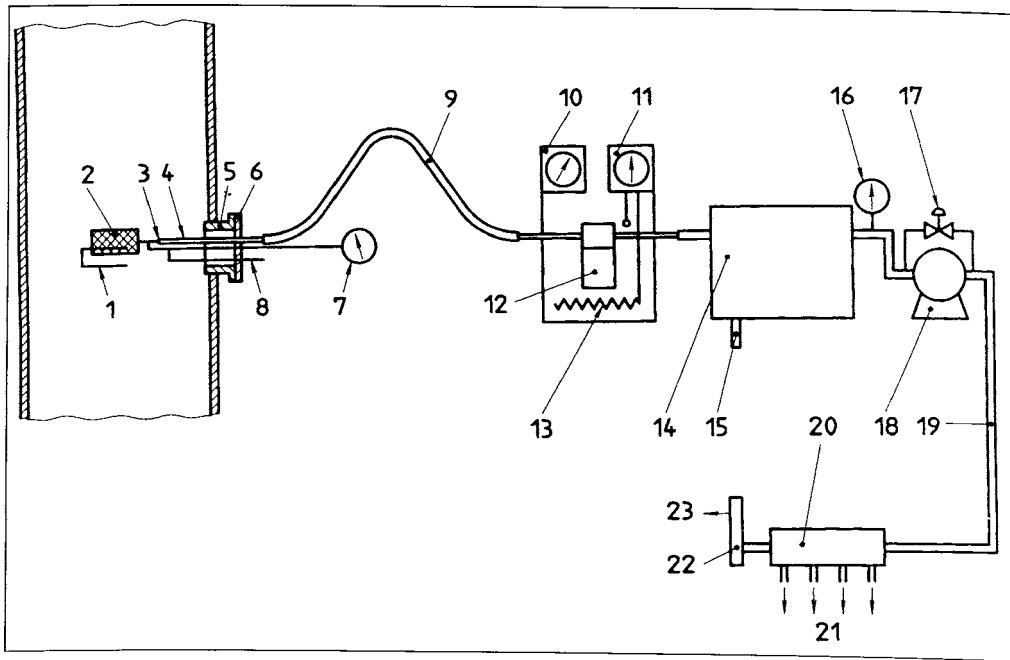

NOTE—Key:

1	Baffle	13	Heater
2	In-stack Filter	14	Refrigeration Unit
3	Tee	15	Water Discharge
4	Probe	16	Vacuum Gage
5	Sampling Port	17	Bypass Valve
6	Cap	18	Pump
7	Pressure Gage	19	Sampling Line (Heating Optional)
8	To Zero and Span Gases	20	Manifold
9	Heat-traced Sampling Line	21	To Analyzer(s)
10	Temperature Controller (Line)	22	Rotameter
11	Temperature Controller (Box)	23	Vent
12	Filter		

FIG. 1 Extractive Sampling and Conditioning System

ASTM D5835-95(2007)

<https://standards.iteh.ai/catalog/standards/sist/af52f5b4-58d4-4650-9bd9-81480b5d318e/astm-d5835-952007>

5. Representative Factors

5.1 Nature of the Source:

5.1.1 The representativeness of the determination of gaseous concentration in enclosed gas streams depends on several factors:

5.1.1.1 The heterogeneity of the process stream, such as variations in concentration, temperature, or velocity across the duct caused by moisture or gas stratification,

5.1.1.2 Gas leakage or air infiltration and continuous gas reactions, and

5.1.1.3 Random errors due to the finite nature of the sample and the sampling procedure adopted to obtain a representative sample.

5.1.2 Representativeness may be difficult to achieve for the following reasons:

5.1.2.1 Nature of the source (for example, cyclic, continuous, or batch),

5.1.2.2 Concentration level of the gas,

5.1.2.3 Size of the source, and

5.1.2.4 Configuration of the duct network where samples are extracted.

5.1.3 Where there are difficulties due to the nature of the source as noted in 5.1.2, establish the concentration profile for each operating condition and to determine the best sampling location.

5.1.3.1 Some sources may have more variability in process (for example, cyclic variation) and, consequently, any time dependent measurement may be less representative of the average concentration if a full cycle of variability is not sampled.

5.1.4 Before any measurements are carried out, it is necessary to become familiar with the pertinent operating characteristics of the process from which emissions are to be sampled and determined. These operating characteristics include, but are not necessarily limited to, the following:

5.1.4.1 Mode of process operation (cyclic, batch charging, or continuous),

5.1.4.2 Process feed rates and composition,

5.1.4.3 Fuel rates and composition,

5.1.4.4 Normal operating gas temperatures and pressures,

5.1.4.5 Operating and removal efficiency of the pollution control equipment,

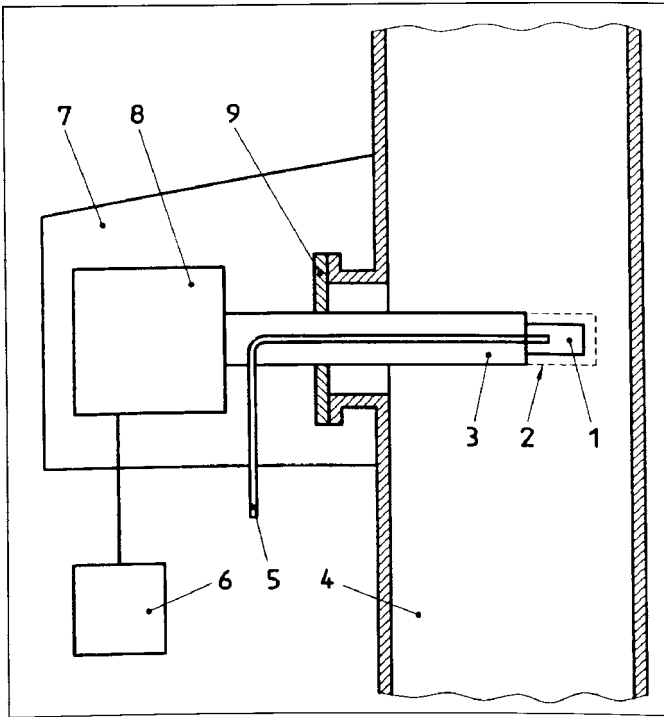

- NOTE—Key:
- | | |
|------------------------|-------------------|
| 1 Measurement Cell | 6 Data Recorder |
| 2 Probe Filter | 7 Protective Hood |
| 3 Probe | 8 Transceiver |
| 4 Duct or Stack | 9 Probe Mounting |
| 5 Gas Calibration Line | |

FIG. 2 Non-Extractive Point Monitor

5.1.4.6 Configuration of the ducts to be sampled leading to gas stratification,

5.1.4.7 Volumetric gas flow rates, and

5.1.4.8 Expected gas composition and likely interfering substances. (**Warning**—Exercise caution if the duct to be sampled is under pressure or vacuum, or at a high temperature.)

5.2 Location:

5.2.1 *Inspection Parameters*—Perform an inspection of the physical characteristics of the test site to evaluate factors such as:

- 5.2.1.1 Safety of the personnel,
- 5.2.1.2 Location of the flow disturbances,
- 5.2.1.3 Accessibility of the sampling site,
- 5.2.1.4 Available space for the sampling equipment and instrumentation and possible scaffolding requirements,
- 5.2.1.5 Availability of suitable electrical power, compressed air, water, steam, etc., and
- 5.2.1.6 Sampling port locations. (**Warning**—Use the electrical equipment in accordance with the local safety requirements. Where a potentially explosive or hazardous atmosphere is suspected, apply particular attention and precautions to ensure the safety of the operations.)

5.2.2 *Sampling Site Location*:

5.2.2.1 It is necessary to ensure that the gas concentrations measured are representative of the average conditions inside the duct or stack. The requirements for the extractive sampling of gas may be not as stringent as those for particulate material.

It is important that the sampling location be removed from any obstructions that will seriously disturb the gas flow in the duct or stack. The pollutant can have cross sectional variation. The concentration at various points of the cross-section shall first be checked, in order to assess the homogeneity of the flow and to detect any infiltration of air or gas stratification, etc. If a preliminary analysis of cross-section at measurements taken indicates more than $\pm 15\%$ variation in concentrations, and if an alternative acceptable location is not available, multi-point sampling is recommended.

5.2.2.2 Multi-point sampling may be achieved either by moving the probe from point to point or having a probe with multiple access ports. Usually, the cross sectional concentration of gaseous pollutants is uniform, because of the diffusion and turbulent mixing. If so, it is only necessary to sample at one point within the stack or duct to determine the average concentration. Extract gas samples near the center of the stack sampling site. When using nonextractive systems, obtain a concentration as representative as possible, but ensure that the instrument location is representative.

5.3 *Gas Concentration, Velocity, and Temperature Profile*—Before commencing sampling, determine if there are any spatial or temporal fluctuations in the gas concentrations by conducting a preliminary survey of the gas concentration, temperature, and velocity. Measure the concentration, temperature, and velocity at the sampling points several times to obtain their spatial and temporal profiles. Conduct this survey when the plant is operating under conditions that will be representative of normal operation and determine whether the sampling position is suitable and whether the conditions in the duct are satisfactory (see 5.1.2).

5.3.1 The following test methods may be used to determine gas concentration, temperature, and velocity:

- 5.3.1.1 O_2 —Test Method D3154, EPA Test Methods 3 and 3a,
- 5.3.1.2 CO_2 —Test Method D3154, EPA Test Methods 3 and 3a,
- 5.3.1.3 CO —EPA Test Method 10,
- 5.3.1.4 SO_2 —EPA Test Methods 6 and 6c,
- 5.3.1.5 NO_x —Test Method D1608, EPA Test Methods 7 and 7e,
- 5.3.1.6 *Gas Temperature*—Test Method D3154, EPA Test Method 2, and
- 5.3.1.7 *Gas Velocity*—Test Method D3154, EPA Test Method 2.

5.4 *Other Factors*—The principle of operation and the components of the instrument systems can significantly affect the degree to which a collected sample is representative of the measured gas in the source. For example, a point sampling extractive system requires more attention to sampling site location than an across-the-stack in-situ sampling system. Furthermore, sampling lines should not be composed of materials that have gas adsorbing properties that can affect the response time of the measurement section (see Table A1.1).

5.4.1 Exercise care to preserve the integrity of the sample taken, by a good selection of equipment, and appropriate heating, drying, and leak testing, etc. In addition, other factors

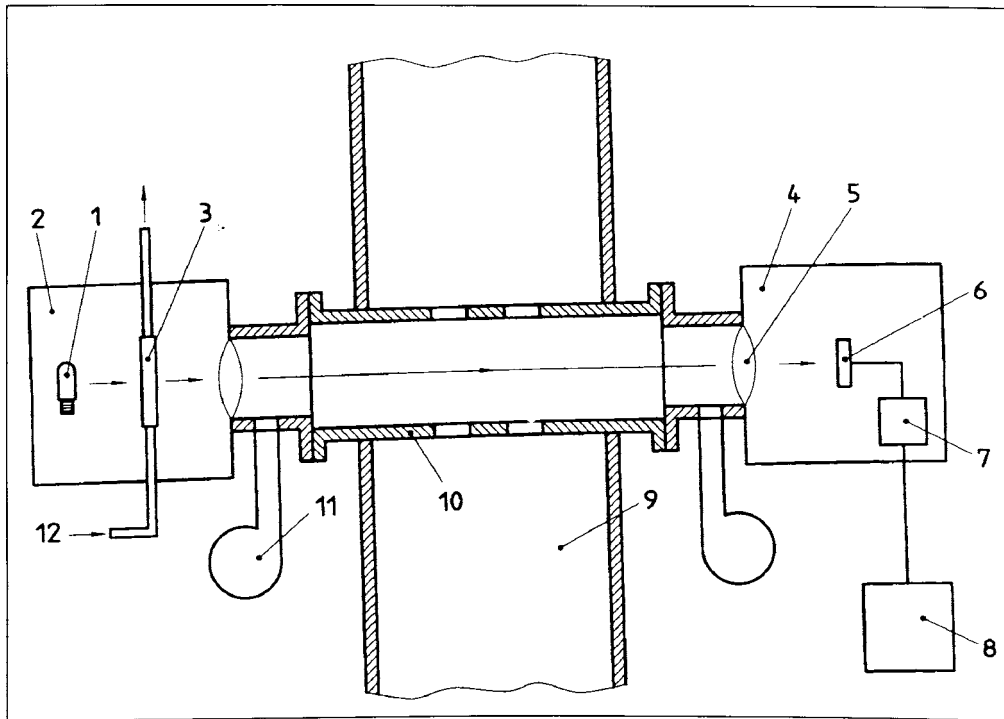

NOTE—Key:

1	Lamp	7	Electronic Module
2	Transmitter Assembly	8	Data Recorder
3	Internal Gas Calibration Cell	9	Stack or Duct
4	Receiver Assembly	10	Alignment/Calibration Pipe
5	Protective Windows	11	Purge Air Blower
6	Detector	12	Gas Calibration Line

FIG. 3 Non-Extractive Path Monitor

such as corrosion, synergies, reaction with components, decomposition, and adsorption might affect the integrity of a sample.

6. Equipment

6.1 Recommended construction materials are described in Annex A1.

6.2 Components of Extractive Sampling Equipment:

6.2.1 *Primary Filter*—The filter medium shall be constructed of an appropriate alloy (such as a specific stainless steel cast alloy), quartz borosilicate, ceramics, or another suitable material. A filter that retains particles greater than 10 μm is recommended. A secondary filter might be required as well (see 6.2.4). The filter medium may be located outside the duct or at the tip of the sample probe (6.2.2). If placed at the tip of the probe, a deflector plate may be added to prevent particle build-up on the leading edge of the filter. This will prevent blockage of the filter. Avoid contamination of the filter with particulate matter where condensate may react with gases, resulting in erroneous result.

6.2.2 Probe:

6.2.2.1 *Metal Probes*—The choice of the metal depends basically on the physical and chemical properties of the sample and on the nature of the gas to be determined. Mild steel is

subject to corrosion by oxidizing gases and may be porous to hydrogen. Thus, it is preferable to have stainless steel or chromium steels that can be used up to 900°C. Other special steels or alloys can be used above this temperature. Heat the probe if condensation occurs in its interior and cool it with an air or water jacket when sampling in very hot gases. Electrically ground metal probes since high voltages are easily generated in dry gas streams, causing particulate matter to be collected on the probe surface. Grounding is particularly important when employed in an explosive atmosphere.

6.2.2.2 *Refractory Probes (see Annex A1)*, generally made of vitreous silica, porcelain, mullite or recrystallized alumina. They are fragile and may warp at high temperatures; with the exception of silica, they may also crack from thermal shock. Borosilicate glass probes can withstand temperatures up to 500°C and vitreous silica probes up to 1000°C. Some refractors of advanced ceramic materials can withstand temperatures higher than 1000°C.

6.2.3 *Heated Sampling Line Connected to Moisture Removal Assembly:*

6.2.3.1 The sampling line shall be made of stainless steel, or Polytetrafluoroethylene (PTFE).

6.2.3.2 The tube diameter shall be adequate to provide a flow rate that is sufficient to feed the monitors, bearing in mind