



Designation: D6670 – 01(Reapproved 2007)

## Standard Practice for Full-Scale Chamber Determination of Volatile Organic Emissions from Indoor Materials/Products<sup>1</sup>

This standard is issued under the fixed designation D6670; the number immediately following the designation indicates the year of original adoption or, in the case of revision, the year of last revision. A number in parentheses indicates the year of last reapproval. A superscript epsilon ( $\epsilon$ ) indicates an editorial change since the last revision or reapproval.

### 1. Scope

1.1 This practice is intended for determining volatile organic compound (VOC) emissions from materials and products (building materials, material systems, furniture, consumer products, etc.) and equipment (printers, photocopiers, air cleaners, etc.) under environmental and product usage conditions that are typical of those found in office and residential buildings.

1.2 This practice is for identifying VOCs emitted and determining their emission rates over a period of time.

1.3 This practice describes the design, construction, performance evaluation, and use of full-scale chambers for VOC emission testing.

1.4 While this practice is limited to the measurement of VOC emissions, many of the general principles and procedures (such as methods for evaluating the general performance of the chamber system) may also be useful for the determination of other chemical emissions (for example, ozone, nitrogen dioxide). Determination of aerosol and particle emissions is beyond the scope of this document.

### 2. Referenced Documents

#### 2.1 ASTM Standards:<sup>2</sup>

- D1356 Terminology Relating to Sampling and Analysis of Atmospheres
- D1914 Practice for Conversion Units and Factors Relating to Sampling and Analysis of Atmospheres
- D3686 Practice for Sampling Atmospheres to Collect Organic Compound Vapors (Activated Charcoal Tube Adsorption Method)
- D5116 Guide for Small-Scale Environmental Chamber De-

terminations of Organic Emissions from Indoor Materials/Products

D5197 Test Method for Determination of Formaldehyde and Other Carbonyl Compounds in Air (Active Sampler Methodology)

D5466 Test Method for Determination of Volatile Organic Chemicals in Atmospheres (Canister Sampling Methodology)

D6196 Practice for Selection of Sorbents, Sampling, and Thermal Desorption Analysis Procedures for Volatile Organic Compounds in Air

D6345 Guide for Selection of Methods for Active, Integrative Sampling of Volatile Organic Compounds in Air

E779 Test Method for Determining Air Leakage Rate by Fan Pressurization

E1333 Test Method for Determining Formaldehyde Concentrations in Air and Emission Rates from Wood Products Using a Large Chamber

IEEE/ASTM SI-10 - Standard for Use of the International System of Units (SI): The Modern Metric System

#### 2.2 Other Documents:

ACGIH 1995 (American Conference of Governmental Industrial Hygienists), Threshold Limit Values (TLVs) for Chemical Substances and Physical Agents in the Work Environment and Biological Exposure Indices. Cincinnati, OH

ASHRAE 2004, ASHRAE 62.1-2004 "Ventilation for Acceptable Indoor Air Quality," American Society of Heating, Refrigerating, and Air-Conditioning Engineers, Atlanta, GA.

ASHRAE 2004, ASHRAE 62.2-2004 "Ventilation and Acceptable Indoor Air Quality in Low-Rise Residential Buildings," American Society of Heating, Refrigerating, and Air-Conditioning Engineers, Atlanta, GA.

CMEIAQ (Consortium for Material Emissions and Indoor Air Quality) Final Report 1.1 A Method for Sampling and Analysis of Volatile Organic Compounds in Emission Testing of Building Materials. Institute for Research in Construction, National Research Council Canada, Ottawa, Ontario K1A 0R6, Canada

CMEIAQ Final Report 3.1 Models for Predicting Volatile

<sup>1</sup> This practice is under the jurisdiction of ASTM Committee D22 on Air Quality and is the direct responsibility of Subcommittee D22.05 on Indoor Air.

Current edition approved April 1, 2007. Published June 2007. Originally approved in 2001. Last previous edition approved in 2001 as D6670 - 01. DOI: 10.1520/D6670-01R07.

<sup>2</sup> For referenced ASTM standards, visit the ASTM website, www.astm.org, or contact ASTM Customer Service at service@astm.org. For *Annual Book of ASTM Standards* volume information, refer to the standard's Document Summary page on the ASTM website.

Organic Compound (VOC) Emissions from Building Materials, Institute for Research in Construction, National Research Council Canada, Ottawa, Ontario K1A 0R6, Canada

ECA-IAQ (European Collaborative Action) “Indoor Air Quality and Its Impact on Man,” 1997. Total volatile organic compounds (TVOCs) in indoor air quality investigations. Report No. 19. EUR 17675 EN. Luxembourg: Office for Official Publications of the European Community

U.S. EPA Compendium of Methods for Determination of Toxic Organic Compounds in Ambient Air, Report EPA-600/4-89/017 available through the National Technical Information Service, Springfield, VA 22161; PB90-116989. This report contains TO-17

World Health Organization, 1989 “Indoor Air Quality: Organic Pollutants,” EURO Reports and Studies No. 111, World Health Organization, Copenhagen, pp. 1-64

### 3. Terminology

3.1 *Definitions*—or definitions and terms commonly used in ASTM standards, including this standard, refer to Terminology **D1356**. For an explanation of units, symbols, and conversion factors, refer to Practice **D1914**.

3.2 *Definitions of Terms Specific to This Standard:*

3.2.1 *chamber loading ratio*—the total amount of test specimen divided by the net air volume of the environmental test chamber in  $1/m^3$ ,  $m/m^3$ ,  $m^2/m^3$ , and  $m^3/m^3$  for unit, line, area, and volume emission sources, respectively (see 3.2.4).

3.2.2 *clean air*—defined in this practice as air that satisfies all of the following criteria:

(1) concentrations of total VOCs  $\leq 10 \mu\text{g}/m^3$ ;

(2) concentration of any individual compound to be measured  $\leq 2.0 \mu\text{g}/m^3$ ;

(3) particle concentrations  $\leq 100$  particles/ $\text{ft}^3$  of  $0.5 \mu\text{m}$  diameter or larger (that is, the Class M2 according to ASHRAE 1995 **(1)**<sup>3</sup> clean room requirement for  $>0.5 \mu\text{m}$  diameter particles;

(4) concentrations of ozone and other potentially reactive species such as nitrogen oxides ( $\text{NO}_x$ ) and sulfur oxides ( $\text{SO}_x$ ) should be at or below detectable levels (for example,  $<10 \mu\text{g}/m^3$ ).

3.2.3 *clean air change rate (1/h)*—the flow rate of clean air (defined in 3.2.2) in  $m^3/h$  supplied into the chamber divided by the net air volume (in  $m^3$ ) of the environmental test chamber (that is, volume of an empty chamber minus the volume taken by all contents in the chamber during testing such as the test specimen, sampling ports). The clean air flow rate may be measured directly at the clean air supply duct. The clean air change rate can also be determined by conducting a tracer gas test (for example, a tracer gas decay test) in the chamber. Note that the air exchange rate (in units of 1/h) is abbreviated as ACH.

3.2.4 *emission factor*—the mass of a VOC or total VOC emitted per unit time and per unit amount of source tested.

<sup>3</sup> The boldface numbers in parentheses refer to the list of references at the end of this practice.

Depending on the type of source, the amount of source may be expressed by its exposed surface area (that is, an area source such as a painted gypsum wallboard surface), its dominant dimension (that is, a line source such as a caulk or sealant), its mass, or its standard setup (that is, a “unit” source such as a predefined work station system). As a result, the unit for the emission factor will be  $\text{mg}/h$ ,  $\text{mg}/(m \text{ h})$ ,  $\text{mg}/(m^2 \text{ h})$ ,  $\text{mg}/(\text{kg h})$ , and  $\text{mg}/(m^3 \text{ h})$  for the “unit,” line, area, mass, and volume emission sources, respectively.

3.2.5 *emission rate*—the mass of a VOC or total VOC emitted from all the test specimen(s) present in the space per unit time,  $\text{mg}/h$ . It is equal to the emission factor times the amount of emission source.

3.2.6 *full-scale chamber*—a room-size chamber that can house the material/product to be tested in its real dimensions, and provide the required environmental conditions (temperature, relative humidity, and air velocity) that are similar to the material/product use in full-scale room conditions.

3.2.7 *time zero*—the start time when the emission factor is measured. It will depend on the purpose of the testing. For example, time zero may be defined as the time when the test specimen is loaded into the chamber if the test specimen is prepared outside the chamber. Alternatively, when the emission during an application process (for example, painting) is to be tested, time zero may be defined as the time when the application begins.

3.2.8 *total volatile organic compound (TVOC)*—the sum of the concentrations of all the individual VOCs captured from air by a given sorbent, or a given combination of several sorbents, thermally desorbed into and eluted from a given gas chromatographic system, and measured by a given detector. For VOC definition, see Terminology **D1356**.

NOTE 1—The measured value of TVOC will depend on the collection and desorption efficiency of the sorbent trap; the efficiency of transfer to the GC column; the type and size of the GC column; the GC temperature program and other chromatographic parameters; and the type of GC detector.

3.2.9 *tracer gas*—a gaseous compound that can be used to determine the mixing characteristics of the test chamber and be a cross-check of the air change rate. The tracer gas must not be emitted by the test specimen and must not be contained in the supply air.

### 4. Summary of Practice

4.1 Materials or products are placed in a full-scale test chamber within which temperature, relative humidity, and air change rate are controlled according to set parameters. Air is sampled at the exhaust of or inside the chamber, and analyzed by appropriate methods to identify the major emitted compounds and their concentrations as a function of time. The measured concentrations are then used to determine the emission rates, and/or the emission characteristics of the material or product. This information can be used to assess the contribution of the materials and products to the concentrations in the space of interest (for example, the occupied zone).

## 5. Significance and Use

5.1 VOCs emitted from materials/products affect indoor air quality (IAQ) in buildings. To determine the impact of these emissions on IAQ, it is necessary to know their emission rates over time. This practice provides guidelines for using a full-scale environmental chamber for testing large materials and full-scale material systems/assemblies.

5.2 While this practice is developed for measuring VOC emissions, the chamber facilities and methods of evaluation presented in this practice are also useful for a variety of purposes including: (1) testing the emissions during the application process (for example, painting), or other related sources; (2) developing scaleup methods (for example, from small chamber results to a full-scale scenario); (3) studying the interaction between sources and sinks, and validating source/sink models which are the basis for IAQ prediction; and (4) testing interactions between source emissions and other compounds in the air (for example, NO<sub>x</sub>, ozone, SO<sub>x</sub>).

## 6. Principles

6.1 *Tests Under Uniform Chamber Concentration Conditions*—Assuming that the concentration of each emitted VOC tested in the chamber air is uniform as a result of good mixing, the concentration is then governed by the mass balance equation:

$$V \frac{dC(t)}{dt} = R(t) - QC(t) - S(t) \quad (1)$$

where:

- $V$  = air volume of the chamber excluding air volume taken by test specimens, m<sup>3</sup>;
- $t$  = time, h;
- $C(t)$  = concentration of the emitted VOC in the air exhausted from the chamber (can be measured at the chamber return or exhaust air ducts), mg/m<sup>3</sup>;
- $R(t)$  = emission rate of the source(s) in the chamber, mg/h;
- $Q$  = clean air flow rate supplied to the chamber (measured at clean air supply duct or determined by a tracer gas test), m<sup>3</sup>/h; and,
- $S(t)$  = sink term representing loss (or re-emission if negative) of the VOC due to adsorption/desorption effect on the interior surfaces of the chamber and ducts, mg/h (see section 8.6 for its determination).

Based on Eq 1, the VOC emission rates of a test specimen as a function of time can be determined by measuring the concentrations of the air exhausted from the chamber and the clean airflow rate (refer to Section 11 for the actual calculation procedure). The concentrations and clean airflow rate must be determined for the same temperature condition since the air volume changes with air temperature. For example, when testing products that generate significant heat (for example, copiers), the exhaust air temperature will be higher than the supply air temperature. If the concentration is measured at the chamber exhaust while airflow rate is measured at the chamber supply, the supply airflow rate must be first adjusted to the equivalent airflow rate under the exhaust air temperature (that

is, multiplied by the ratio of exhaust to supply air temperature in degrees Kelvin) before it is used for determining the emission rate.

Note that, in addition to the uniform VOC concentration assumption, Eq 1 also assumes no chemical reaction in the chamber, no air entry into the chamber other than the supply air, and a negligible VOC concentration at the supply air, compared to that measured at the chamber exhaust. The validity of using Eq 1 depends on how well the chamber's actual operation meets these assumptions. Therefore, the performance of the chamber must be evaluated against certain criteria in order to obtain reliable and reproducible test results (see Section 8).

6.2 *Tests Under Non-Uniform Concentration Conditions*—The full-scale chamber system can also be used to simulate the room airflow conditions in real buildings, which are not necessarily well mixed (for example, in the case of a displacement ventilation system). In this case, the VOC concentrations measured within a defined occupied zone in the chamber (for example, concentrations measured at the center of or various locations within the chamber) can be used directly to simulate the impact of the test materials/products on the VOC concentration levels in the room under a specified material/product loading ratio and ventilation rate conditions that are similar to those expected in real buildings. Such tests may be useful in evaluating complex field situations. However, a detailed understanding of air movement and emission dynamics for each simulation is necessary in order to extrapolate the test results to other field situations.

Typical airflow patterns and air distributions in ventilated spaces may be simulated by appropriate designs of supply air diffusers and return air grilles with appropriate recirculated airflow rate if the goal is to assess emissions under realistic airflow conditions. The total air change rate (outdoor/clean airflow rate plus the recirculated airflow rate) in office buildings may range from 1.0 to 9.0/h, depending on the heating/cooling requirements for the space. Typical types of air diffusers and airflow patterns in ventilated rooms are described in ASHRAE 1997c (1).<sup>3</sup>

6.3 *Variables Affecting Emission Rates*—The emission of pollutants from indoor materials/products generally involves three mass transfer processes: (1) diffusion of pollutants from within the material to the surface; (2) thermal dynamic mass equilibrium conditions at the material/air interface (that is, at the surface); and (3) convection from the surface to the ambient air. Variables affecting emission rates include those related to the materials/products themselves (emitting source variables) and those related to the environment within which they are tested or used (environmental variables). Other factors that may affect emission rates include chemical reactions or operating conditions of the test product (for example, emissions from office machines may depend upon conditions of use).

6.3.1 *Emitting Source Variables*—Emitting source variables include the physical and chemical properties of the materials/products/application such as chemical composition, density, thickness, internal structure, surface characteristics, and ways materials are applied. These are related to raw materials,

additives, the manufacturing processes, and operating conditions. These variables influence the type of VOCs that are emitted, their diffusion coefficients within the material, their adsorption/desorption equilibrium constants over the surface, and ultimately their emission rate profiles.

The physical and chemical properties of manufactured products may change with time and may be affected by environmental conditions. Therefore, it is necessary to know the age of materials or products to be tested. It is also important to document the history (for example, environmental conditions during storage and transportation periods before testing) of the test specimens from their manufacture until testing. If the goal of the testing is to compare the emission characteristics of different materials or products of the same type, all test specimens should be approximately the same age and have approximately the same history of exposure to environmental conditions.

**6.3.2 Environmental Variables**—Local environmental conditions can significantly affect VOC emissions. Major factors include temperature, relative humidity, air motion (velocity and turbulence), and VOC concentrations in the ambient air. The ventilation rate in test chambers (or building space) and the loading (amount of product used in a certain space volume) also affect the VOC emissions, since they affect the local VOC concentrations and airflow conditions in the chamber/space. These environmental factors can change the VOC emission rates at any given time and, therefore, produce different emission profiles. The following sections briefly review the effects of these environmental factors.

**6.3.2.1 Temperature**—An increase in the temperature of the materials and or the ambient air can result in an increase in diffusivities and evaporative mass transfer coefficients. More importantly, increasing temperature will significantly increase the vapor pressure of VOCs. For instance, a temperature increase from 23 to 33 °C will increase the mass transfer coefficient for decane by only 6 %, but will increase the vapor pressure for decane by 83 %. This will lead to an increase in VOC emission rates, since emission rate is proportional to the vapor pressure of the VOC for “wet” emitting sources. The strength of this temperature effect depends on specific materials and VOCs emitted according to Wolkoff 1998 (2) and Van der Wal et al. 1997 (3). Relationships between the ambient air temperature and emission rates have yet to be developed. Full-scale chamber tests are currently conducted under a standard temperature (for example, 23 ± 0.5 °C for non heat-generating products). Specimens are, therefore, preconditioned under the same temperature before testing.

For products that generate significant heat (for example, copy machines), a relatively large variation of air temperature and airflow pattern in the chamber may be present due to the convective heat transfer from the test product. Ideally, the chamber air temperature should be controlled to typical indoor air temperatures when evaluating heat generating devices, as happens in mechanically ventilated buildings [Brown, 1999 (4)]. Where this is not possible due to limitations of the chamber system, the test protocol should define the chamber operating procedures consistent with the test objectives and the test

protocol should address the impact of temperature on determination and comparability of emission rates.

**6.3.2.2 Relative Humidity**—Relative humidity may affect emissions of pollutants that are hydrophilic or pollutants generated by chemical reactions with water. It may also affect VOC emissions from materials that are hygroscopic since the adsorbed water may change the diffusion properties of the material and how the VOC desorbs from the surface. For emission sources that contain water (for example, water-based paints, water-based cleaners, and water-based adhesives), relative humidity may have a profound impact on the VOC emissions because it controls the rate of water evaporation from the source. The extent to which the relative humidity affects VOC emissions depends on specific materials and VOCs emitted according to Wolkoff 1998 (2) and Roache et al. 1996 (5).

As detailed information on the effect of relative humidity on emission rates is not available, chamber tests are usually conducted under a single relative humidity (for example, 50 ± 5 % RH) for products that do not adsorb or generate significant amounts of moisture. Ideally, test specimens should be preconditioned under the test relative humidity condition before testing. However, this is usually not practical because exposing the test specimen to conditioned air also means emitting VOCs before the test is actually started. As a result, test products are usually wrapped or sealed in their original package materials/containers for temperature conditioning only before testing.

For moisture-adsorbing products (for example, fresh furniture materials) or moisture-generating products (for example, printers, liquid chemical products), a larger variation of relative humidity may be allowed in the chamber. Similar to the temperature variation in the chamber when testing a heat-generating product (see section 6.3.2.1), the moisture variation in the chamber when testing moisture-adsorbing or moisture-generating products also depends on the chamber operation. Specific chamber operating procedure and acceptable variability of relative humidity in the chamber should be established in a product-specific test protocol based on the test objectives.

**6.3.2.3 Air Velocity and Turbulence**—Air velocity and turbulence affect the evaporative mass transfer from both solid and liquid sources. For “wet” materials such as paints, stains, and varnishes, whose initial emission period is primarily controlled by evaporative mass transfer, increasing the air velocity and turbulence will lead to an increase in emission rates of VOCs. The effect becomes smaller as the materials become drier according to Roache et al. 1996 (5) and Zhang et al. 1996a (6). For dry materials such as carpets, wood-based products, and polyvinyl chloride (PVC) floorings, air velocity and turbulence affect emission rates only within the first 5 to 10 h of being exposed to the ambient air. After that, the effect becomes insignificant because the emissions will be controlled by internal diffusion, according to Awad 1999 (7), Yang 1999 (8), Wolkoff et al. 1996 (9), Little et al. 1994 (10), and Roache et al. 1998 (5).

In office and residential buildings, the magnitude of air velocities over material surfaces is typically in the range of 0 to 0.25 m/s according to Mathews et al. 1987 (11) and Zhang et al. 1995 (12). Turbulence kinetic energy is typically in the

range of 0 to 0.01 (m/s)<sup>2</sup>. In full-scale chambers, these air velocity and turbulence levels can be simulated if the testing purpose is to simulate a real room airflow condition. Because the actual air velocity and turbulence levels will be different from location to location in the chamber, multi-point measurements should be taken near the surfaces (for example, 1.0 cm from the surface) of test specimens to verify that the desired air velocity and turbulence levels are achieved. This is especially important for testing convective-controlled emission sources such as paints and wood stains. For internal diffusion-controlled emission sources such as carpets and engineered wood products, precise controls of the air velocity and turbulence over the surfaces of test specimens are not required unless the emission rates during the first 5-10 h are of interest. For internal diffusion-controlled emission sources a general specification on air velocity (for example, in the range of 0.05 to 0.25 m/s) is usually sufficient.

**6.3.2.4 VOC Concentrations in Air, Air Change Rate, and Loading Ratio**—For an emitting material, the VOC concentration at the material surface is higher than that in the surrounding air. A higher VOC concentration in the air will lead to a lower concentration gradient between the material surface and the surrounding air, and hence a lower convective mass transfer rate from the surface to the air. The emission rate decreases as the VOC concentration in the chamber increases (for example, during the initial emission period of “wet” materials).

VOC concentrations in a chamber/space are dependent on the air change rate (ventilation rate) and/or material loading ratio for a given emission source. A high air change rate or a low material loading ratio will result in a low concentration in the chamber or space, and hence increase the emission rates. In addition, increasing the air change rate can also result in an increase in velocity and turbulence levels over the emitting surfaces, and hence the convective mass transfer coefficient.

Chamber tests can be conducted to simulate the impact of outdoor/clean air supply on room VOC concentrations. In office and residential buildings, outdoor air change rates may range from 0.05 to 1.5 air changes per hour [ASHRAE 1997a (13), ASHRAE 1997b (14), and Reardon and Zhang 1995 (15)]. ASHRAE 62.1-2004 and ASHRAE 62.2-2004 (16) specifies the outdoor air flow requirements for achieving acceptable IAQ. Additional recirculated air is required to meet the heating or cooling requirements for the space. If the purpose of a chamber test is to evaluate the impact of clean/outdoor air change rate on the VOC concentration levels, a small mixing fan (for example, those used for cooling a microcomputer) may be placed in the chamber to achieve adequate mixing for emission tests (see section 6.1). When this is done, however, airflow patterns in actual rooms are not simulated in the chamber.

**6.4 The Role of Source Emission Models**—Source emission models are used to describe the VOC emission rates (or emission factor) as a function of time, environmental conditions (temperature, humidity, and air velocity, etc.), and/or source (initial VOC content and composition, density, etc.) variables. These models are useful for designing full-scale experiments. For example, they can be used to select air sampling intervals and experimental conditions. They are also

useful for analyzing emission test results from which the coefficients of selected models are estimated (see Section 11). Finally, the models can be used to extrapolate short-term emission test data to a longer term and from environmental chamber test conditions to field conditions. However, care should always be exercised in the extrapolation since any model has its limitations [CMEIAQ Final Report 3.1, Guo 1996 (17), Little et al., 1994 (10), and Zhang and Shaw 1997 (18)].

## 7. Facilities and Equipment

**7.1 General Considerations for Chamber System Design and Construction**—A complete full-scale chamber test facility consists of: a full-scale chamber and its heating, ventilation, and air-conditioning (HVAC) system for air supply and conditioning, an air sampling and analysis system, and a data acquisition and recording system. The system should be housed in a clean and air-conditioned laboratory space. Following are the general design and construction considerations:

**7.1.1** The chamber should be large enough to accommodate the products to be tested and allow the simulation of the product use in full-scale room conditions.

**7.1.2** The chamber HVAC system must provide stable and accurate control of the airflow rate, temperature, differential pressure (pressure relative to the ambient pressure outside the chamber), and relative humidity within the chamber, and have the capacity to operate over the entire range of desired operating/testing conditions, considering the generation of heat and moisture from sources to be tested.

**7.1.3** The chamber, air cleaning, and distribution components must be constructed of materials that minimize adsorption and emission of VOCs [for example, stainless steel, glass, polytetrafluoroethylene (PTFE)]. Fans and bearings must be designed to prevent intrusion of emissions from lubricants into the clean air system.

**7.1.4** The chamber system should be airtight in order to minimize any air leakage between the inside and the outside of the chamber system.

**7.1.5** The chamber system should be capable of providing sufficient mixing in the chamber for testing under the uniform VOC concentration assumption. If the chamber is intended to simulate airflow patterns, air distribution, air velocity, and turbulence levels that are typically found in real ventilated rooms, in addition to having the capability to accurately determine the emissions from indoor products, the chamber should be designed to accommodate both types of studies.

**7.1.6** The chamber system should be able to provide on-line monitoring of the test conditions including airflow rates (clean and recirculated air), air temperature, relative humidity, and differential pressure inside the chamber and in the ventilation ducts. For example, a data acquisition system may be set up to monitor these conditions every minute. (Note that the reading frequency required for achieving good control accuracy may be much smaller, but will depend on the chamber system.) This will facilitate the detection of any malfunction of the system and help diagnose problems.

**7.1.7** The chamber system should have adequate sampling ports for taking air samples both within the chamber and in the ventilation ducts.

7.1.8 All components of the chamber system (such as ducts, fans, cooling/heating coils) should be thoroughly cleaned before they are installed. Effort should also be made to avoid contamination during the construction period.

7.1.9 The chamber system and all components should be easily accessible for cleaning and maintenance.

## 7.2 *The Full-scale Chamber:*

7.2.1 *Construction Material*—Materials such as stainless steel, glass, aluminum, and PTFE coating are acceptable for the construction of the interior surfaces of the chamber, with stainless steel being the most common choice. Type 304 or 316 stainless steel with No. 4 finishing (a general purpose polished finish that finds wide applications in restaurant, dairy, food processing, medical, and chemical equipment as well as various architectural products) may be used as the interior wall and floor surface. For example, 11 gage stainless steel panels may be used for the floor, and 14 gage used for the ceiling and walls. Sections can be fastened together by continuous welding at the joints of two panels and by tack welding to their supporting frame. Some discoloration may be observed in the vicinity of the welded lines due to the heat and oxidation in the welding process. The interior welded joints may be cleaned by wire brushing or mechanical grinding. If a highly polished surface finish is desired, matte-finish stainless steel sheets should be used since they can be more easily polished mechanically after construction to a semi-mirror finish (equivalent to the sterile finish used in hospitals). Ideally, it is desirable to electro-polish the surface to minimize the sink effect on the surfaces, but this is generally not practical because of the size of the chamber.

7.2.2 *Chamber Door*—The chamber door must be large enough to accommodate the largest material/product components to be tested. The seals between the door and chamber surfaces must be made of non-emitting and non-adsorbing materials (such as PTFE) and be adequate to maintain chamber leak rates at or below acceptable levels. PTFE gaskets and door clamps are usually used. If the door opens to the inside and the chamber will operate under a positive pressure relative to the outside of the chamber, the positive pressure in the chamber will improve the tightness of the door during chamber operation. If the door opens to the outside and the chamber is operated under a positive pressure, at least two clamps on each side of the doorframe are usually necessary to ensure proper airtightness. In either case, the door should be operable from inside and outside the chamber for safety purposes. For experiments in which a technician will enter and exit the chamber (painting, etc.), it is desirable to have a small entry chamber with its own airtight door.

7.2.3 *Lighting and Observation Windows*—Lights may be installed above ceiling glass panels sealed with PTFE gaskets. PTFE-gasket-sealed observation windows may be installed on walls or the chamber door.

7.2.4 *Insulation*—The floor, ceiling, walls, and door of the chamber should be well insulated to minimize the influence of temperature fluctuation outside the chamber on the air temperature in the chamber.

7.2.5 *Air Sampling Ports*—Sampling ports should be installed at desired locations depending on the test purpose (for

example, at the mid-height of walls). Stainless steel feed-through connectors with sealing caps may be used for this purpose. The length of the sampling line between the sampling device (for example, adsorbent tube) and the sampling location should be minimized in order to reduce the effect of VOC adsorption/desorption in the sampling line on the measurements.

## 7.3 *The HVAC System for the Full-scale Chamber:*

7.3.1 *System Design*—Different approaches may be used to supply controlled and conditioned airflow to the chamber. **Figs. 1 and 2** show two different example systems. Depending on the purpose of testing, System 1 (**Fig. 1**) may operate in several modes: (1) full exhaust (FE) mode, in which all the supply air is exhausted with no air recirculated back to the chamber; (2) recirculation (RC) mode, in which part or all of the air from the chamber is recirculated back to the chamber; and (3) by-pass (BP) mode, in which part or all the air from the chamber is recirculated back to the chamber, bypassing the heating and cooling coils and humidifier. The BP mode may be used to determine if the HVAC components have significant adsorption/desorption effects for the VOCs measured. System 2 (**Fig. 2**) uses a completely different design for air supply, conditioning, and handling of air to the chamber. Air supply is from a compressor at 690 kPa, regulated to 150 kPa before reaching a flow-regulating valve that is linked via process controllers to a turbine flowmeter. Chamber pressure can be at 0-250 Pa above the ambient pressure in the laboratory space, and requires no extraction fan for operation. An air-conditioning plant operates between the flow regulating valve and the meter, conditioning only the supply air. Air enters the chamber along a central, perforated duct at ceiling level. Two similar ducts at floor level are connected to a supply duct via a fan so that chamber air can be recirculated. Extra heater and chiller components are located in the recirculation duct. The clean supply air is forced from the chamber under positive pressure via six exhaust ports in the chamber walls. This chamber can operate under the FE and RC modes described above, but without humidification of recirculated air.

7.3.2 *Air Preconditioning*—The air supplied to the system may come either directly from outdoors or from the laboratory space. The supply air must be preconditioned to avoid contamination of the chamber system and to allow the chamber system to operate at all designed temperature and humidity conditions. For example, in System 1 (**Fig. 1**), preconditioning is accomplished by passing the air through a particulate filter, an electric preheater, a chilled water cooling unit, and a desiccant dehumidifier. A single-speed fan is used to circulate the air in the preconditioning loop. This preconditioning loop allows the system to operate at -40 to 30 °C outdoor air temperature and up to 95 % relative humidity. The preconditioning equipment should be sized to condition the air to the temperature and humidity ranges that can be handled by the conditioning components downstream in the recirculation loop to achieve the required control accuracy. In example System 2, air delivered from the compressor is passed through two oil-coalescing filters and a refrigerative dryer, and then improved by purification.

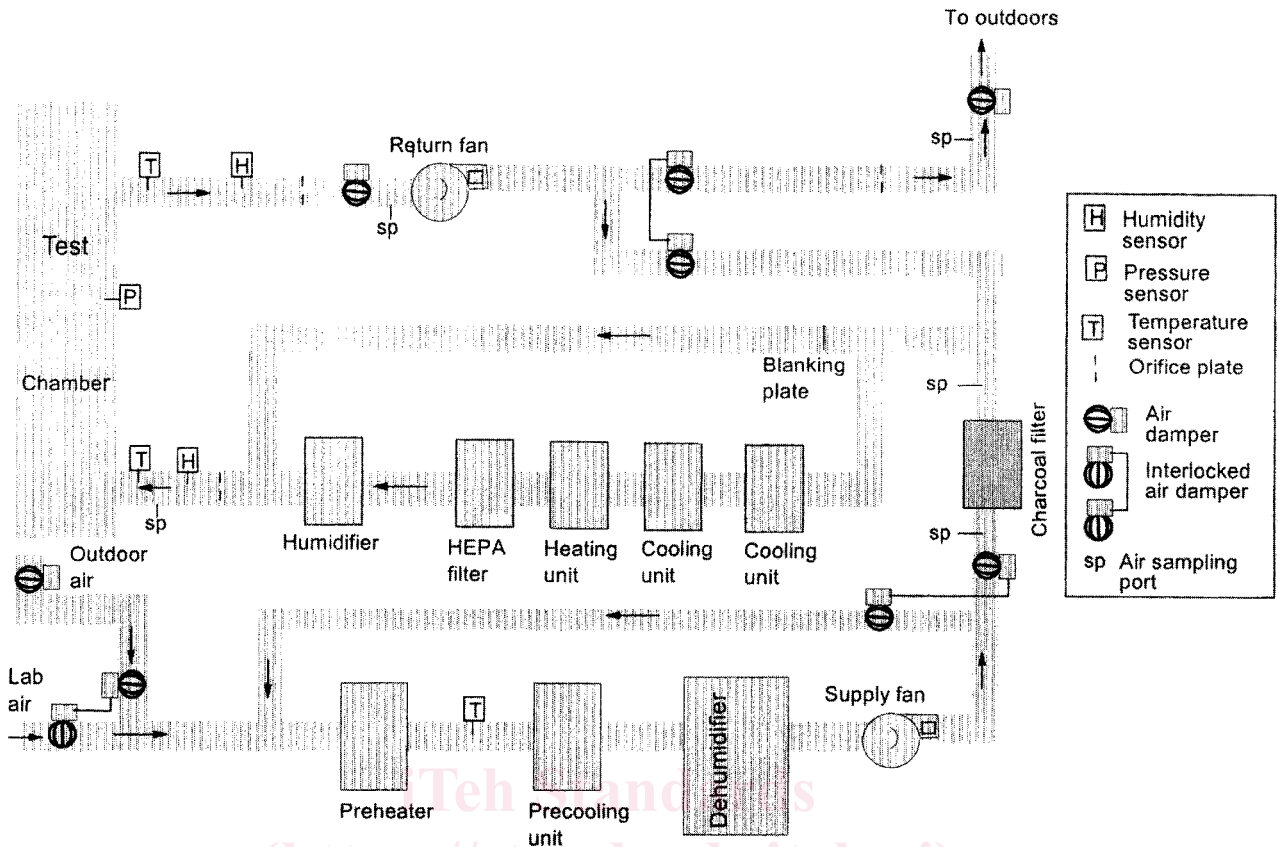

FIG. 1 Schematic of a Full-Scale Chamber System—Example 1 (EPA and NRC Chambers)

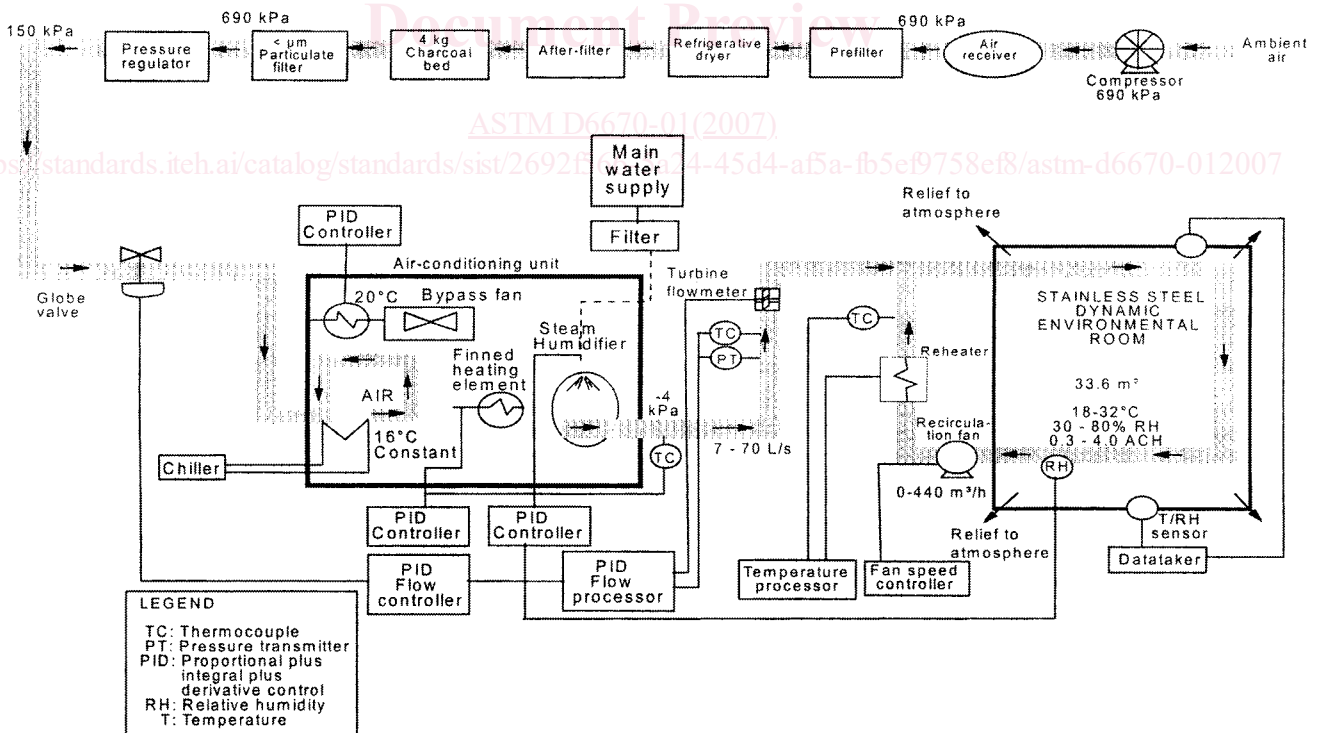

FIG. 2 Schematic of a Full-Scale Chamber System—Example 2 (OCSIRO Chamber)

7.3.3 Air Purification—The supply air should be cleaned to satisfy the criteria of clean air (see section 3.2.2). This can be

accomplished by passing the air through a catalytic oxidation

system, activated carbon filters or packed beds, and a high-efficiency particulate air (HEPA) filter. These filters or chemical adsorption beds should have sufficient capacity and be easily accessible for replacement.

**7.3.4 Heating, Cooling, and Humidification**—The supply air should be further conditioned to achieve the required temperature and humidity control. This may be achieved by passing air through cooling/heating coils and a steam or other humidifier. All the components which are exposed to the supply air stream should be made of inert materials such as stainless steel or tin-plated copper. PTFE gaskets must be used to seal the various joints (for example, between air duct sections, between the cooling/heating component and ducts). The water supplied to the humidifier must be purified and deionized.

**7.3.5 Control of System Operation**—The operation of the chamber system may be controlled by a stand-alone DDC (direct digital control) controller or a dedicated computer. The set points for airflow rates, temperature, and relative humidity can be set by a microcomputer, which also monitors, displays, and records the operation conditions. The sensor reading frequency should be at least once every second, and the control system should be able to make the control adjustment within 1 min to achieve continuous control. One minute average of the 1 s readings may be recorded every minute. In System 1 (Fig. 1), airflow rates are measured by using orifice plates at the outdoor air supply duct, the preconditioning loop, immediately before the activated carbon adsorber, immediately before and after the chamber, and the exhaust duct. By controlling the positions of the interlocked air dampers at the exhaust and recirculation ducts, the exhaust airflow rate (and therefore the clean air supply flow rate) can be controlled. The total supply airflow rate is controlled by adjusting the position of the air damper upstream of the return fan (Fig. 1). The chamber pressure is controlled by the air damper installed upstream of the activated charcoal filter. These controls are accomplished by PID (proportional integral differential) control algorithms programmed in the DDC or the dedicated computer. In example System 2, temperature, humidity, and supply air flow are controlled by PID-programmable process controllers in all processes except recirculation flow, which is controlled by a fan speed control module (calibrated in-situ). The temperature, humidity, and supply airflow conditions achieved within the chamber are monitored by dual sensors in the chamber and the output from the turbine flowmeter, all connected to a data logger. Chamber pressure is adjusted manually within the 0-250 Pa above the ambient pressure in the laboratory space by opening extra vents in the chamber walls. Recommendations on control accuracy are described in section 8.3.

**7.3.6 Air Distribution in the Chamber**—To achieve good air mixing in the chamber, air should be introduced through air diffusers that create air jets (for example, ceiling radial square diffusers like those used in cold air distribution systems [Kirkpatrick and Elleson 1996 (19)], or introduced through tube(s) with small perforated holes that distribute air evenly across the chamber. The tubes are usually located at the floor or ceiling level. Air is usually exhausted at or close to the ceiling or floor level. If the purpose is to study the spatial distribution of VOC concentrations in ventilated spaces, stainless steel

diffuser(s) should be made to represent actual air diffusers that produce realistic airflow distributions.

#### 7.4 Sample Collection and Analysis:

**7.4.1 General Considerations**—There are many ways to collect, detect, and quantify VOCs emitted from products. Every approach has its applications and limitations. Selection of the appropriate sampling and analysis strategies often depends upon the goals of the testing and resources available as well as the nature of the source emissions. It is often necessary to tailor sampling strategies to test conditions and to analytes of interest and/or employ several sampling strategies in order to characterize emissions from a particular source and test condition. General considerations that are generic to source characterization using large chambers are presented in this practice [see Fortmann et al. 1995 (20) for a more detailed discussion]. Detailed considerations specific to individual sources are beyond the scope of this document. CMEIAQ Final Report 1.1 describes detailed considerations in sampling and analysis for testing VOC emissions from building materials.

Many of the procedures and equipment items utilized for characterization of indoor air source emissions are adapted from methods developed for ambient air sampling and analysis. The general applicability of a particular method for source characterization will depend upon the nature of the source, test conditions, and limitations of the sampling and analysis methods. For example, a broad range of VOC emissions may be collected on sorbent media. Analytes are typically thermally desorbed from the sampling media, concentrated on a secondary trap, then flash-desorbed in an inert gas flow to the column of a gas chromatograph (GC) for separation and subsequent detection and quantitation. Accurate quantitation of chamber emissions depends upon collection efficiency of the sampling system, stability of analytes during storage, transfer efficiency of the concentrator system, separation efficiency of the column, and sensitivity and range of the detection system. Such a system may be optimized for accurate determination of a broad range of non-polar VOCs. Optimization of the system for a particular polar, oxygenated, or reactive species may reduce or preclude recovery of other analytes.

The amount of emissions in a sample may also influence system performance. Sample collection and concentration systems optimized for ambient sampling and analysis may experience incomplete desorption and carryover when used to determine high concentrations that are sometimes encountered in chamber tests (for example, during application and drying phases of paints and coatings). Thus, when embarking upon characterization of a particular source, it is often necessary to conduct pilot tests to evaluate sampling and analysis protocols, and it is often necessary to generate relevant airborne concentrations of target analytes in order to optimize performance and demonstrate the efficacy of sampling and analysis systems. Therefore, a standards generation system that includes a clean air supply, source generators such as diffusion or permeation systems, as well as air temperature, relative humidity, flow control, dilution, mixing, and sampling manifold systems are essential components of a source characterization laboratory.

**7.4.2 Selection of Sampling and Analysis Strategy**—The following approach may be used to develop a sampling and



analysis strategy for a particular source. The first step is to gather information about the possible types and ranges of emissions from the test material. Examine the emission data and test methods employed to determine if exploratory sampling and/or analysis strategies are required to identify compounds that may not have been reported due to the methodology used. The next step may be to conduct scoping tests to evaluate the adequacy of sampling and analysis methods. For products where the chemical composition of the source is known or may be determined by extraction and analysis, it is often possible to implement a mass balance approach to emissions characterization. This approach provides feedback regarding adequacy of emissions sampling and analysis methods, fundamental information about the product that may be central to understanding factors controlling emission rates, and understanding chemical reactions that result in emissions of compounds not observed in the source.

**7.4.3 Selection of Sampling Methods**—VOC emissions from sources that impact the IAQ include very volatile, volatile, semi-volatile, polar, non-polar, oxygenated, and other species of organic compounds. Sampling systems include syringes, sampling loops, sorbent traps, sorbent tubes, cryogenic traps, whole air canisters, and other devices that collect and concentrate analytes of interest. The choice of sampling systems depends upon the nature and concentration of the analytes as well as testing goals. Guidance on selection of sampling systems is provided in Test Methods [D5197](#), [D5466](#), Practice [D6196](#), and Guide [D6345](#). Traps to remove particles or reactive compounds such as ozone may be required upstream of the adsorbent. Whenever a sampling line, probe, or trap is placed upstream of the sample collection device, it may be necessary to demonstrate quantitative recovery of analytes.

There are several methods that are generally applicable to the collection and analysis of VOC emissions from products in chamber tests. These methods include: (1) online sampling without concentration, (2) online sampling with concentration, (3) whole air sampling, and (4) collection on sorbent media. The merits and limitations of each approach are briefly discussed.

**7.4.3.1 Online Sampling Without Concentration**—Online sampling is usually accomplished by means of automated systems consisting of a GC configured with a gas sampling valve, actuator, sample loops, and detector. Typically, air is pulled from the chamber through transfer tubing and the sample loop via a vacuum pump and flow controller. Rotation of the sample valve allows injection of the contents of the loop onto the column of the GC by the carrier gas flow and places the second loop in line with the vacuum pump and sampling lines. This system is efficient when concentrations of emissions are within the method quantitation range and losses to sampling system components do not affect the transfer of analytes from the chamber air to the GC column. Sampling lines should be of minimal length and made of inert materials. Control of temperature may be required in all parts of the system (sampling lines, manifolds, valves, loops, transfer tubing) to prevent loss or carryover, depending on the compounds to be measured.

**7.4.3.2 Online Sampling With Concentration**—Due to the low concentrations of VOCs often encountered in emissions testing, it is often necessary to concentrate analytes from the air stream. The purpose of the concentration step is two-fold: (1) to lower the method detection limits, and (2) to collect the analytes but pass water vapor so as to reduce potential interference of water vapor on performance of the GC column and detector. For example, an online concentration system may have two VOC traps. The sample air is pulled through one trap during the desorption/analysis phase of the other trap. Each trap may contain a single adsorbent or combination of materials. The range of analytes that can be collected and recovered from the traps will depend upon the composition of the traps and the efficiency of the transfer of analytes from the traps to the GC. Applicability of the online sampling method depends on the required analysis cycle time and the range of analytes that can be collected by the traps and transferred to the GC column without loss or carryover.

**7.4.3.3 Whole Air Samples**—Whole air samples may be collected for subsequent off-line analysis using gas sampling syringes, bags, and lined or passivated stainless steel canisters (see Test Method [D5466](#)). Whole air samples permit sample storage and repeated analyses of the same sample. Gas sampling syringes have limited applicability to source testing due to their relatively low capacity, poor reproducibility, and potential for losses to syringe surfaces. Sampling bags provide an adequate volume of air for concentration, but analytes may diffuse through the bag or be lost to bag surfaces. Canister technology has been proven to be effective for many volatile compounds at ambient concentrations. Source testing often generates atmospheres with high concentrations of pollutants and generates pollutants of less volatility than those for which the canister technology has been developed and demonstrated. Therefore, as with any sampling system, it may be necessary to determine the appropriate application of the technique for a particular source.

**7.4.3.4 Collection of VOCs on Sorbent Media**—Collection on sorbent media is currently the most commonly used approach for indoor air source sampling. Sorbents are packed in glass or metal tubes, and known volumes of air are drawn through them. Analytes collected on these traps may be thermally desorbed to a concentrator unit or extracted with appropriate solvent for liquid injection. Thermal desorption is the most common approach due to ease of use and lower method detection limits.

The air sampling system should include a sorbent tube (or cartridge), an air sampling pump, and an airflow controller which can measure and control the airflow rate through the sampling system to within  $\pm 5\%$  of a specified value. All system components between the chamber and the sorbent tube (or cartridge) should be constructed of chemically inert materials. The sorbent tube or cartridge should be connected directly to the sampling location at the chamber return/exhaust or inside the chamber by using a short ( $<0.4$  m) stainless steel or PTFE tube/connector. The pump should be operated in suction mode downstream of the sorbent tube or cartridge to

avoid contamination of air samples by the pump. Refer to Practice **D6196** and EPA TO17 for selection of appropriate sorbents.

**7.4.3.5 Collection of Carbonyls on Sorbent Media**—For selected low-molecular-weight aldehydes and ketones, compounds are collected and derivatized on cartridges containing silica gel coated with 2,4-dinitrophenylhydrazine (DNPH) (Test Method **D5197**). The derivatized compounds are solvent-extracted and determined by high-performance liquid chromatography (HPLC) with ultraviolet (UV) or photo-diode array detection.

**7.4.4 Selection of Sampling Methods and Protocols**—The following are important factors to consider in the selection of sampling methods and protocols: (1) compounds to be determined, (2) expected concentrations of specific compounds during the tests, (3) collection efficiency, (4) recovery efficiency, (5) amount of water vapor in the sample, (6) storage stability, (7) linear range of the analytical system, (8) analytical method detection and quantitation limits, and (9) artifact formation during collection, thermal desorption, or transfer of the sample to the analytical system.

Sampling volumes and flow rates for sorbent traps used to collect VOCs are selected based upon method quantitation limits, breakthrough volumes of compounds of interest, acceptable pressure drop across the sampling traps, and time resolution required for calculation of emission rates from chamber concentration data. For a particular analyte: the sample volume should be equal to or less than the safe sampling volume (SSV, see Practice **D6196**), the mass collected on the adsorbent trap should be equal to or greater than the method limit of quantitation (LOQ), the sampling flow rate should be below that which causes excessive pressure drop (see manufacturer's recommendations), and the sampling period should be of a duration that permits intended use of the data. The limit of quantitation is defined as the level above which quantitative results may be obtained with a specified degree of confidence (**21**, **22**). A proper sampling volume should be determined through a prescreening analysis (section **11.1**). Refer to Practice **D6196** and Guide **D6345** for more guidance on sorbent selections and air sampling.

**7.4.5 Selection of Chemical Analysis Systems**—The appropriate instrumentation for the determination of emissions from products and processes depends upon the nature of the emissions and testing goals.

**7.4.5.1 VOC Chemical Analysis Systems**—A gas chromatograph (GC) equipped with capillary column and flame ionization (FID) or mass spectral (MS) detector is commonly employed for identification and quantification of VOC emissions. Due to the complexity of emissions from many types of sources, a GC/MS system may be considered essential for identification of VOC emissions from most sources. A GC/FID system is often useful for quantification of emissions due to the sensitivity and broad linear dynamic range of the detector. Other GC detectors such as electron capture (ECD) or photoionization (PID) detector are useful for specific types of compounds. If VOCs are present at relatively high concentrations (~1 ppm), detection systems such as Fourier transform infrared (FTIR) or mass spectral detection with atmospheric

pressure ionization interface (API/MS) may be useful for identification of compounds that do not pass through the GC columns to the detector.

**7.4.5.2 Formaldehyde and Other Carbonyl Analysis Systems**—Many carbonyl compounds may be collected on silica gel coated with DNPH and determined by liquid chromatography with UV or photo-diode array detectors (see Test Method **D5197**). Other wet chemical colorimetric techniques are available for monitoring specific compounds such as formaldehyde.

**7.4.5.3 Other Chemical Analysis Systems**—Process equipment such as photocopiers, laser printers, and air cleaners may emit ozone and NO<sub>x</sub>. Combustion sources such as cigarette smoke may emit SO<sub>x</sub> as well. Standard source and ambient monitoring equipment and sampling protocols may be utilized or adapted to determine concentrations of these pollutants in chambers and chamber exhaust.

**7.4.6 Quality Control and Quality Assurance**—Due to the complexity of source emissions testing, careful planning is usually required to ensure meaningful data. A quality assurance plan identifies the critical data needed to meet testing goals and provides a framework for collecting data that will help ensure that the data are of sufficient quantity and quality to meet the goals of the testing program. Certain kinds of quality control data are necessary to assess the performance of sampling and analysis systems. These data include results of periodic flow rate checks of sampling systems, analysis of replicate samples, analysis of field and laboratory blanks, spiked field control samples, daily tuning criteria for MS systems, and results of daily mid-range calibration check samples. Guidance on development of quality assurance and quality control programs is available from several sources [for example, EPA QA/R-5 (**23**)].

## 8. Performance Evaluation

### 8.1 Background Concentration of the Chamber System:

**8.1.1** The background concentration of the chamber system should have a mean value of less than 15 % of the lowest concentration to be measured in a test, and a standard deviation of less than 50 % of its mean value. As a general guideline for quality assurance, the background concentration of a full-scale chamber should satisfy the following criteria:

**8.1.1.1** TVOC  $\leq 10 \mu\text{g}/\text{m}^3$ ;

**8.1.1.2** any individual compound to be measured  $\leq 2.0 \mu\text{g}/\text{m}^3$ ;

**8.1.1.3** particulate  $\leq 100$  particles/ft<sup>3</sup> of 0.5  $\mu\text{m}$  diameter or larger, which is the Class M2 clean room requirement for >0.5  $\mu\text{m}$  diameter particles [ASHRAE 1997c (**16**)], and

**8.1.1.4** ozone and other potentially reactive species (NO<sub>x</sub>, SO<sub>x</sub>, etc.) should be at or below their detectable levels (for example, each reactive compound <10  $\mu\text{g}/\text{m}^3$ ).

**8.1.2** The background concentration of the chamber system should be checked with the chamber operating under the required test conditions (temperature, relative humidity, and airflow rates). Air samples should be taken from the exhaust air duct to represent the background contamination of the chamber system. The following procedure can be used for commissioning the chamber system immediately after the construction: