**Machinery for forestry — Portable chain-
saw safety requirements and testing —**

Part 2:

Chain-saws for tree service

*Matériel forestier — Exigences de sécurité et essais des scies à chaîne
portatives —*

iTeh STANDARD PREVIEW
Partie 2: Scies à chaîne pour l'élagage des arbres
(standards.iteh.ai)

ISO 11681-2:2011

<https://standards.iteh.ai/catalog/standards/sist/b91b3945-7610-4de8-8172-344667d78d45/iso-11681-2-2011>



iTeh STANDARD PREVIEW (standards.iteh.ai)

ISO 11681-2:2011

<https://standards.iteh.ai/catalog/standards/sist/b91b3945-7610-4de8-8172-344667d78d45/iso-11681-2-2011>



COPYRIGHT PROTECTED DOCUMENT

© ISO 2011

All rights reserved. Unless otherwise specified, no part of this publication may be reproduced or utilized in any form or by any means, electronic or mechanical, including photocopying and microfilm, without permission in writing from either ISO at the address below or ISO's member body in the country of the requester.

ISO copyright office
Case postale 56 • CH-1211 Geneva 20
Tel. + 41 22 749 01 11
Fax + 41 22 749 09 47
E-mail copyright@iso.org
Web www.iso.org

Published in Switzerland

Contents

Page

Foreword	iv
Introduction	v
1 Scope	1
2 Normative references	1
3 Terms and definitions	2
4 Safety requirements and/or protective measures	3
4.1 General	3
4.2 Handles	3
4.3 Hand protection	3
4.4 Balance and holding moment	5
4.5 Protection against injury by kickback	5
4.6 Chain catcher	6
4.7 Spiked bumper	6
4.8 Chip discharge	6
4.9 Guide-bar cover	6
4.10 Engine starting device	6
4.11 Engine stopping device	7
4.12 Throttle control	7
4.13 Drive sprocket guard	8
4.14 Clutch	8
4.15 Protection against contact with parts under high voltage	9
4.16 Protection against contact with hot parts	9
4.17 Fuel and oil systems	10
4.18 Exhaust gases	11
4.19 Chain lubrication	11
4.20 Chain tensioning	11
4.21 Attachment device	11
4.22 Vibration	12
4.23 Noise	12
4.24 Electromagnetic immunity	12
5 Information for use	13
5.1 Instruction handbook	13
5.2 Marking	16
5.3 Warnings	16
5.4 Test of labels	17
Annex A (informative) Working with tree service chain-saws from rope and harness	19
Annex B (informative) List of significant hazards	24
Bibliography	26

Foreword

ISO (the International Organization for Standardization) is a worldwide federation of national standards bodies (ISO member bodies). The work of preparing International Standards is normally carried out through ISO technical committees. Each member body interested in a subject for which a technical committee has been established has the right to be represented on that committee. International organizations, governmental and non-governmental, in liaison with ISO, also take part in the work. ISO collaborates closely with the International Electrotechnical Commission (IEC) on all matters of electrotechnical standardization.

International Standards are drafted in accordance with the rules given in the ISO/IEC Directives, Part 2.

The main task of technical committees is to prepare International Standards. Draft International Standards adopted by the technical committees are circulated to the member bodies for voting. Publication as an International Standard requires approval by at least 75 % of the member bodies casting a vote.

Attention is drawn to the possibility that some of the elements of this document may be the subject of patent rights. ISO shall not be held responsible for identifying any or all such patent rights.

ISO 11681-2 was prepared by Technical Committee ISO/TC 23, *Tractors and machinery for agriculture and forestry*, Subcommittee SC 17, *Manually portable forest machinery*.

This third edition cancels and replaces the second edition (ISO 11681-2:2006), which has been technically revised.

ISO 11681 consists of the following parts, under the general title *Machinery for forestry — Portable chain-saw safety requirements and testing*:

- *Part 1: Chain-saws for forest service* (standards.iteh.ai)
- *Part 2: Chain-saws for tree service*

[ISO 11681-2:2011](http://standards.iteh.ai)

<https://standards.iteh.ai/catalog/standards/sist/b91b3945-7610-4de8-8172-344667d78d45/iso-11681-2-2011>

Introduction

This document is a type-C standard as stated in ISO 12100.

The machinery concerned and the extent to which hazards, hazardous situations or hazardous events are covered are indicated in the scope of this document.

When requirements of this type-C standard are different from those which are stated in type-A or type-B standards, the requirements of this type-C standard take precedence over the requirements of the other standards for machines that have been designed and built according to the requirements of this type-C standard.

At the time of publication of this edition, it was not state of the art to require that starting of the machine would be always possible without causing movement of the saw chain. Such a requirement will be considered for inclusion in the next revision of this International Standard.

iTeh STANDARD PREVIEW (standards.iteh.ai)

ISO 11681-2:2011

<https://standards.iteh.ai/catalog/standards/sist/b91b3945-7610-4de8-8172-344667d78d45/iso-11681-2-2011>

iTeh STANDARD PREVIEW
(standards.iteh.ai)

ISO 11681-2:2011

<https://standards.iteh.ai/catalog/standards/sist/b91b3945-7610-4de8-8172-344667d78d45/iso-11681-2-2011>

Machinery for forestry — Portable chain-saw safety requirements and testing —

Part 2: Chain-saws for tree service

1 Scope

This part of ISO 11681 gives safety requirements and measures for their verification for the design and construction for tree service of portable, combustion-engine, hand-held chain-saws having a maximum mass — without guide bar or saw chain and with tanks empty — of 4,3 kg, intended to be used, with the right hand on the rear handle and left hand on the front handle, by a trained operator for pruning and dismantling standing tree crowns, and by persons having read and understood the safety requirements provided in the instruction handbook, using the appropriate personal protective equipment (PPE). Methods for the elimination or reduction of hazards arising from the use of these machines and the type of information on safe working practices to be provided by the manufacturer are specified.

This part of ISO 11681 deals with all significant hazards, hazardous situations and hazardous events relevant to these machines when they are used as intended and under conditions of misuse which are reasonably foreseeable by the manufacturer.

NOTE See Annex B for a list of significant hazards.

This part of ISO 11681 is applicable to chain-saws manufactured after its date of publication.

2 Normative references

The following referenced documents are indispensable for the application of this document. For dated references, only the edition cited applies. For undated references, the latest edition of the referenced document (including any amendments) applies.

ISO 6531:2008, *Machinery for forestry — Portable chain-saws — Vocabulary*

ISO 6533, *Forestry machinery — Portable chain-saw front hand-guard — Dimensions and clearances*

ISO 6534, *Forestry machinery — Portable chain-saw hand guards — Mechanical strength*

ISO 6535, *Portable chain-saws — Chain brake performance*

ISO 7293, *Forestry machinery — Portable chain-saws — Engine performance and fuel consumption*

ISO 7914:2002, *Forestry machinery — Portable chain-saws — Minimum handle clearance and sizes*

ISO 7915, *Forestry machinery — Portable chain-saws — Determination of handle strength*

ISO 8334, *Forestry machinery — Portable chain-saws — Determination of balance and maximum holding moment*

ISO 9518, *Forestry machinery — Portable chain-saws — Kickback test*

ISO 10726, *Portable chain-saws — Chain catcher — Dimensions and mechanical strength*

ISO 12100:2010, *Safety of machinery — General principles for design — Risk assessment and risk reduction*

ISO 13772, *Forestry machinery — Portable chain-saws — Non-manually actuated chain brake performance*

ISO 13849-1:2006, *Safety of machinery — Safety-related parts of control systems — Part 1: General principles for design*

ISO 13849-2, *Safety of machinery — Safety-related parts of control systems — Part 2: Validation*

ISO 13857:2008, *Safety of machinery — Safety distances to prevent hazard zones being reached by upper and lower limbs*

ISO 14982:1998, *Agricultural and forestry machinery — Electromagnetic compatibility — Test methods and acceptance criteria*

ISO 22867, *Forestry and gardening machinery — Vibration test code for portable hand-held machines with internal combustion engine — Vibration at the handles*

ISO 22868, *Forestry and gardening machinery — Noise test code for portable hand-held machines with internal combustion engine — Engineering method (Grade 2 accuracy)*

IEC 60745-1:2006, *Hand-held motor-operated electric tools — Safety — Part 1: General requirements*

3 Terms and definitions

For the purposes of this document, the terms and definitions given in ISO 6531 and ISO 12100 and the following apply.

NOTE Figure 1 shows an example of a chain-saw within the scope of this part of ISO 11681.

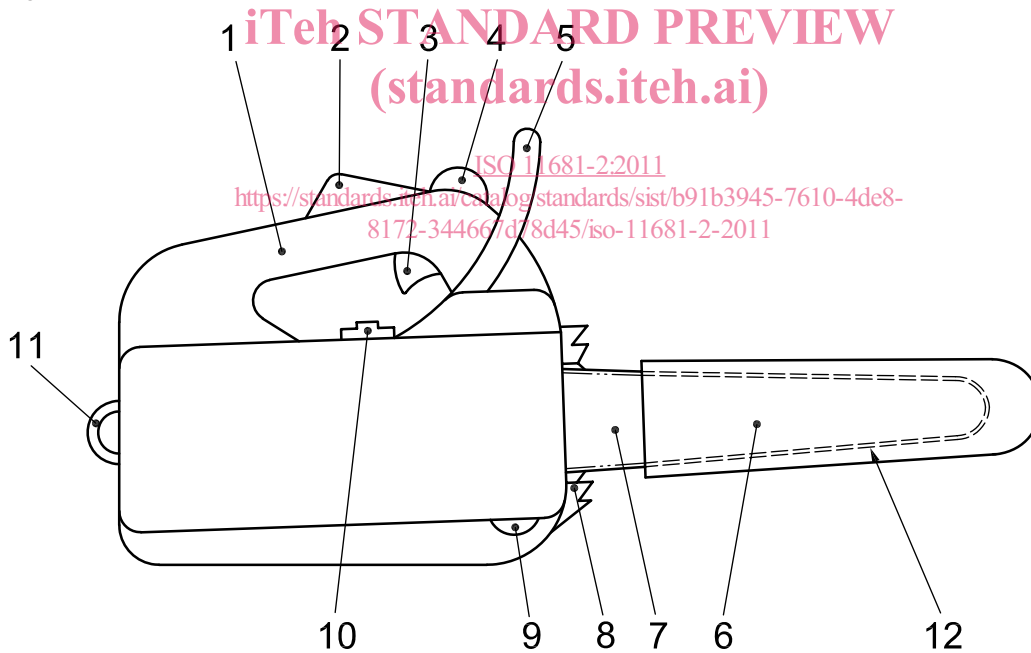

Key

- | | |
|-----------------------------|---------------------|
| 1 rear handle | 7 guide bar |
| 2 throttle trigger lock-out | 8 spiked bumper |
| 3 throttle trigger | 9 chain catcher |
| 4 front handle | 10 stopping device |
| 5 front hand guard | 11 attachment point |
| 6 guide-bar cover | 12 saw chain |

Figure 1 — Example of chain-saw

3.1**trained operator**

person who has competence and knowledge in

- the use of, and particular hazards associated with using, a chain-saw (for tree service work) manufactured in accordance with the provisions of this part of ISO 11681, and
- the precautions to be taken to limit these hazards, including the wearing of the recommended personal protective equipment (PPE)

4 Safety requirements and/or protective measures**4.1 General**

Machines shall comply with the safety requirements and/or protective measures of this clause. In addition, the machine shall be designed according to the principles of ISO 12100 for relevant but not significant hazards which are not dealt with by this part of ISO 11681.

The safe operation of a chain-saw also depends on the safe environment associated with the use of personal protective equipment (PPE), such as gloves, slip-resistant footwear, and leg, eye, hearing and head protective equipment, as well as safe working procedures (see 5.1).

Except where otherwise specified in this part of ISO 11681, the safety distances specified in ISO 13857:2008, 4.2.4.1 and 4.2.4.3, shall be met.

iTeh STANDARD PREVIEW
(standards.iteh.ai)

4.2 Handles**4.2.1 Requirements**

Chain-saws shall have a handle for each hand. These handles shall be designed such that

- they can be fully gripped by an operator wearing protective gloves,
- they provide the necessary sureness of grip by their shaping and surface, and
- they conform to the dimensions and clearances given for tree-service chain-saws in ISO 7914 (see also 4.12.1).

The strength of both handles shall comply with ISO 7915.

Chain-saws having a system for isolating machine vibration from the handles shall be designed so that the operator is able to stop the engine in a controlled manner with the engine stopping device (see 4.11), even in the case of failure of the vibration isolation system.

4.2.2 Verification

Dimensions shall be verified by measurement. Strength requirements shall be verified by testing in accordance with ISO 7915. The possibility of stopping the chain-saw engine when a failure has occurred in the vibration isolation system shall be verified by inspection of the design and by functional testing.

4.3 Hand protection**4.3.1 Protection at front handle****4.3.1.1 Requirements**

A hand guard shall be fitted in the vicinity of the front handle to protect the operator's fingers and hand from injury through contact with the saw chain.

The dimensions of this front hand guard shall comply with ISO 6533. Its strength shall comply with ISO 6534.

4.3.1.2 Verification

Dimensions shall be verified by measurement. Strength requirements shall be verified by testing in accordance with ISO 6534.

4.3.2 Protection at rear handle

4.3.2.1 Requirements

A guard shall be provided along the length of the right side of the bottom of the rear handle to protect the operator's hand from contact with broken chain.

This guard shall extend from the right edge of the handle for at least 30 mm on the guide bar side (see Figure 2) and at least 100 mm lengthwise from the inner rear part of the handle (see Figure 2).

This requirement may also be fulfilled by parts of the machine.

The strength of the rear hand guard shall comply with ISO 6534.

4.3.2.2 Verification

Dimensions shall be verified by measurement. Strength requirements shall be verified by testing in accordance with ISO 6534.

iTeh STANDARD PREVIEW
(standards.iteh.ai)

Dimensions in millimetres

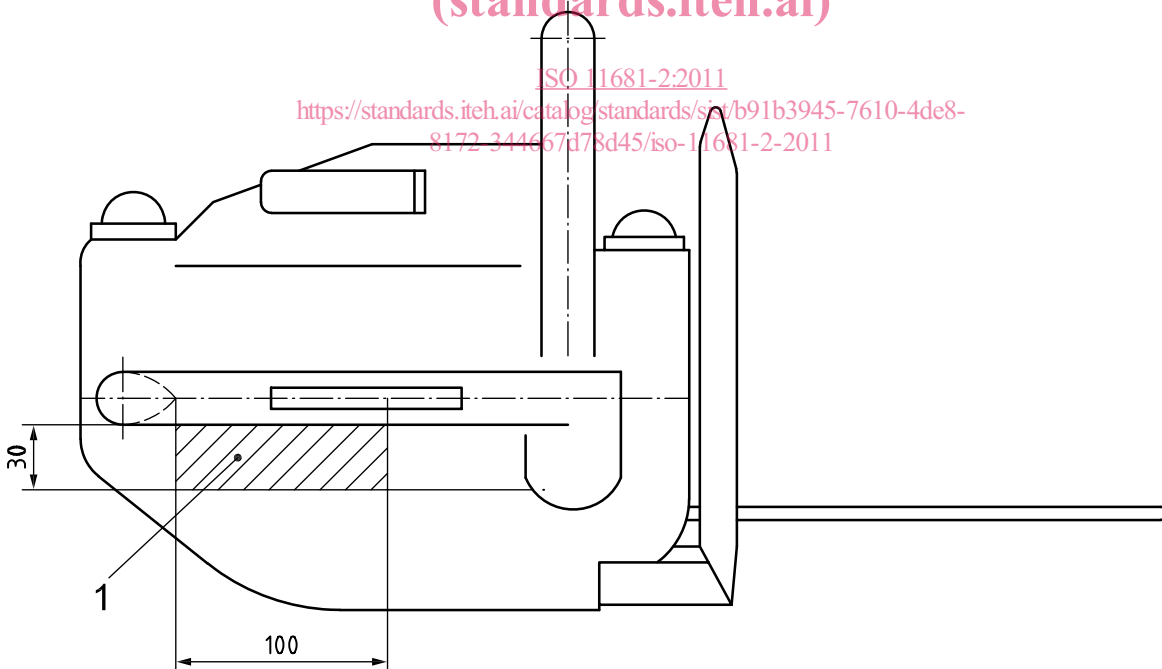

Key

- 1 minimum area covered or guarded to protect hand from broken saw chain

Figure 2 — Minimum dimensions of protection at rear handle

4.4 Balance and holding moment

4.4.1 Requirements

Chain-saws shall be longitudinally balanced to within $\pm 25^\circ$ between the centreline of the guide bar and the horizontal plane, and laterally balanced to within $\pm 10^\circ$ between the guide bar plane and the vertical plane.

The maximum holding moment shall not exceed 6 N·m.

The limits shall be met by the shortest and longest applicable guide bars.

4.4.2 Verification

The angles for longitudinal and lateral balance and the holding moment shall be verified by functional testing in accordance with ISO 8334.

4.5 Protection against injury by kickback

4.5.1 Chain brake

4.5.1.1 Requirements

The chain-saw shall be fitted with a chain brake that can be activated manually by means of the front hand guard. The chain brake release force shall be between 20 N and 50 N and the direction of movement shall be away from the operator.

The average stopping time shall not exceed 0,12 s and the maximum stopping time shall not exceed 0,15 s.

4.5.1.2 Verification

ISO 11681-2:2011

<https://standards.iteh.ai/catalog/standards/sist/b91b3945-7610-4de8-8172-4469706d5430/iso-11681-2-2011>

The chain brake release force and stopping time shall be verified in accordance with ISO 6535.

4.5.2 Non-manual chain brake

4.5.2.1 Requirements

There shall also be a non-manual chain brake system that operates the chain brake when kickback occurs. This system shall meet the requirements for tree-service chain-saws given in ISO 13772.

4.5.2.2 Verification

The non-manually activated chain brake system shall be verified by functional testing in accordance with ISO 13772.

4.5.3 Kickback and chain stop angles

4.5.3.1 Requirements

The computed kickback angle or the chain stop angle, whichever is the lesser, shall be determined for each guide bar and chain specified in the instruction handbook and shall not exceed 25° .

4.5.3.2 Verification

The computed kickback angle and chain stop angle shall be verified by functional testing in accordance with ISO 9518.

4.6 Chain catcher

4.6.1 Requirements

The chain-saw shall be fitted with a chain catcher located, and with dimensions and strength, in accordance with ISO 10726. The chain catcher shall be replaceable.

4.6.2 Verification

Dimensions shall be verified by measurement. Strength requirements shall be verified by testing in accordance with ISO 10726. Means for replacing the chain catcher shall be verified by inspection.

4.7 Spiked bumper

4.7.1 Requirements

The chain-saw shall have provision for mounting a spiked bumper (see Figure 1).

4.7.2 Verification

The provision for mounting a spiked bumper shall be verified by inspection.

4.8 Chip discharge

4.8.1 Requirements

The chain-saw shall be so designed that wood particles are directed below the underside of the saw when it is in an upright (cross-cutting) position.

iTeh STANDARD PREVIEW
(standards.iteh.ai)

[ISO 11681-2:2011](https://standards.iteh.ai/catalog/standards/sist/b91b3945-7610-4de8-8172-344667d78d45/iso-11681-2-2011)

<https://standards.iteh.ai/catalog/standards/sist/b91b3945-7610-4de8-8172-344667d78d45/iso-11681-2-2011>

4.8.2 Verification

The direction of the discharge of wood particles shall be verified by inspection during cross-cutting operations.

4.9 Guide-bar cover

4.9.1 Requirements

The chain-saw shall be provided with a guide-bar cover (see Figure 1), so designed that it remains attached to the guide bar during transport and storage.

4.9.2 Verification

The attachment of the guide-bar cover to the guide bar shall be verified by inspection when holding the chain-saw in any direction.

4.10 Engine starting device

4.10.1 Requirements

The engine starting device shall be a self-contained, battery-powered electric starter and/or a manual starter where the actuator is permanently attached to the machine.

Chain-saws with a manual starter shall have a recoil device for the rope.

Two or more separate and dissimilar actions shall be required to activate the electrical starting device.