



Designation: E 2126 – 07

Standard Test Methods for Cyclic (Reversed) Load Test for Shear Resistance of Walls for Buildings¹

This standard is issued under the fixed designation E 2126; the number immediately following the designation indicates the year of original adoption or, in the case of revision, the year of last revision. A number in parentheses indicates the year of last reappraisal. A superscript epsilon (ϵ) indicates an editorial change since the last revision or reappraisal.

1. Scope

1.1 These test methods cover the evaluation of the shear stiffness, shear strength, and ductility of a wall assembly, including applicable shear connections and hold-down connections, under quasi-static cyclic (reversed) load conditions.

1.2 These test methods are intended for wall assemblies constructed from wood or metal framing with solid sheathing or other bracing methods or structural insulated panels.

1.3 The values stated in inch-pound units are to be regarded as standard. The values given in parentheses are mathematical conversions to SI units that are provided for information only and are not considered standard.

1.4 *This standard does not purport to address all of the safety concerns, if any, associated with its use. It is the responsibility of the user of this standard to establish appropriate safety and health practices and determine the applicability of regulatory limitations prior to use.*

2. Referenced Documents

2.1 ASTM Standards:²

D 2395 Test Methods for Specific Gravity of Wood and Wood-Based Materials

D 4442 Test Methods for Direct Moisture Content Measurement of Wood and Wood-Base Materials

D 4444 Test Methods for Use and Calibration of Hand-Held Moisture Meters

E 564 Practice for Static Load Test for Shear Resistance of Framed Walls for Buildings

E 575 Practice for Reporting Data from Structural Tests of Building Constructions, Elements, Connections, and Assemblies

E 631 Terminology of Building Constructions

2.2 International Organization for Standardization Standard:

ISO 16670:2003 Timber Structures—Joints Made with Mechanical Fasteners—Quasi-static Reversed-cyclic Test Method³

3. Terminology

3.1 For definitions of terms used in this standard, see Terminology E 631.

3.2 Definitions of Terms Specific to This Standard:

3.2.1 *ductility factor, monotonic* (μ), n —the ratio of the ultimate displacement (Δ_m) and the yield displacement (Δ_{yield}) observed in monotonic test.

3.2.2 *ductility ratio, cyclic* (D), n —the ratio of the ultimate displacement (Δ_u) and the yield displacement (Δ_{yield}) observed in cyclic test.

3.2.3 *elastic shear stiffness* (K_e) (see 9.1.4, Fig. 2), n —the resistance to deformation of a wall in the elastic range before the first major event (FME) is achieved, which can be expressed as a slope measured by the ratio of the resisted shear load to the corresponding displacement.

3.2.4 *envelope curve* (see Fig. 1), n —the locus of extremities of the load-displacement hysteresis loops. The envelope curve contains the peak loads from the first cycle of each phase of the cyclic loading. Wall displacement in the positive direction produces a positive envelope curve; the negative wall displacement produces a negative envelope curve. The positive direction is based on outward movement of the hydraulic actuator.

3.2.5 *equivalent energy elastic-plastic (EEEP) curve* (see 9.1.4, Fig. 2), n —an ideal elastic-plastic curve circumscribing an area equal to the area enclosed by the envelope curve between the origin, the ultimate displacement, and the displacement axis. For monotonic tests, the observed load-displacement curve is used to calculate the EEEP curve.

3.2.6 *failure limit state*, n —the point on the envelope curve corresponding to the last data point with the absolute load equal or greater than $10.8 P_{peak}$, as illustrated in Fig. 2a.

3.2.7 *failure load* (P_u), n —the load corresponding to the failure limit state.

3.2.8 *first major event (FME)*, n —the first significant limit state to occur (see *limit state*).

¹ These test methods are under the jurisdiction of ASTM Committee E06 on Performance of Buildings and are the direct responsibility of Subcommittee E06.11 on Horizontal and Vertical Structures/Structural Performance of Completed Structures.

Current edition approved June 1, 2007. Published June 2007. Originally approved in 2001. Last previous edition approved in 2005 as E 2126 – 05

² For referenced ASTM standards, visit the ASTM website, www.astm.org, or contact ASTM Customer Service at service@astm.org. For *Annual Book of ASTM Standards* volume information, refer to the standard's Document Summary page on the ASTM website.

³ Available from American National Standards Institute (ANSI), 25 W. 43rd St., 4th Floor, New York, NY 10036, http://www.ansi.org.

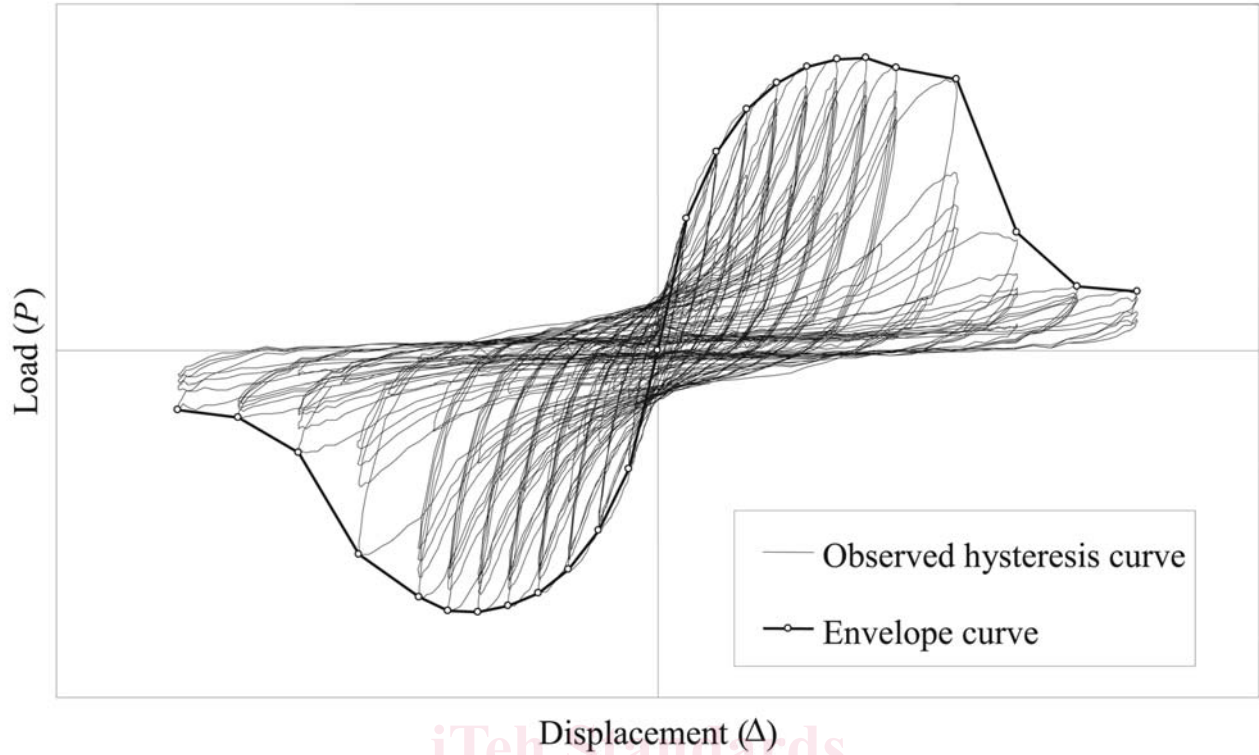

FIG. 1 Examples of Observed Hysteresis Curve and Envelope Curves for Method A

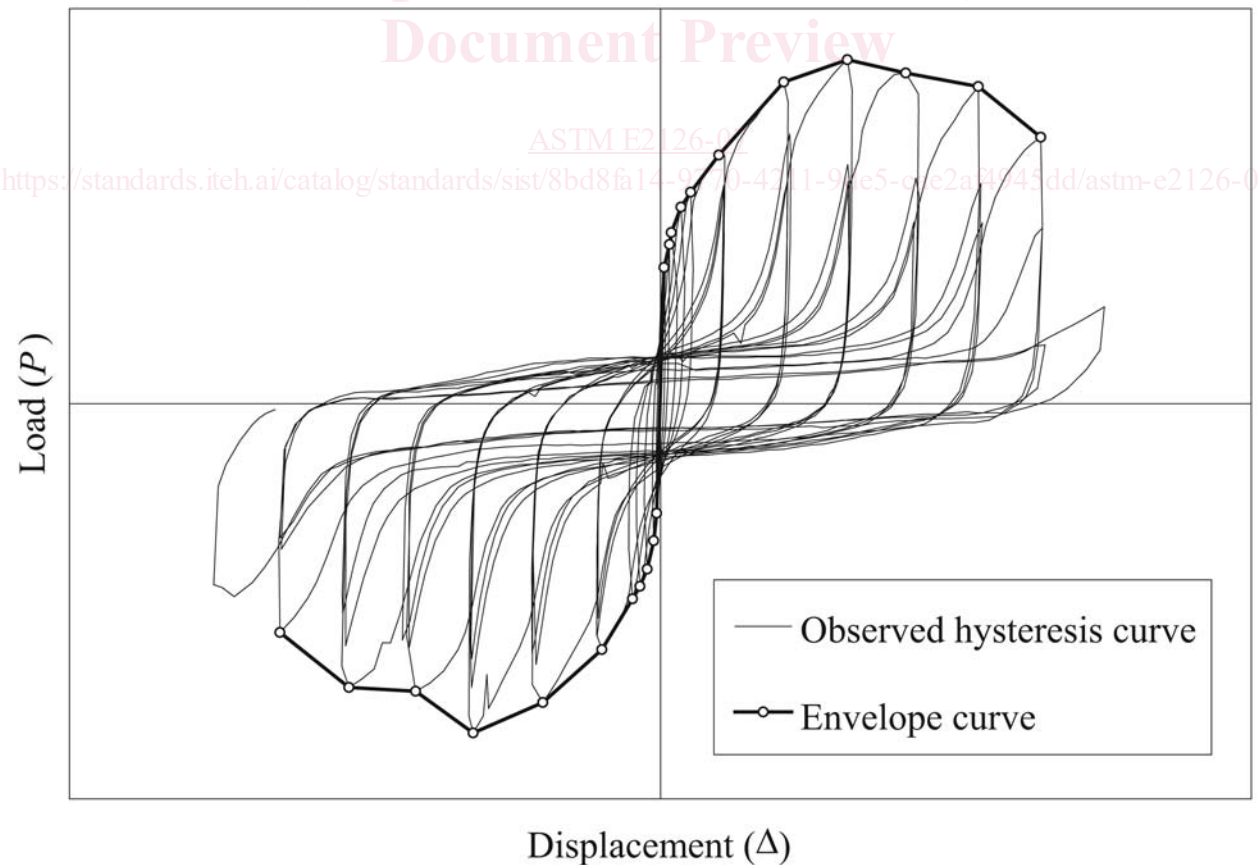

FIG. 1 Examples of Observed Hysteresis Curve and Envelope Curves for Method B (continued)

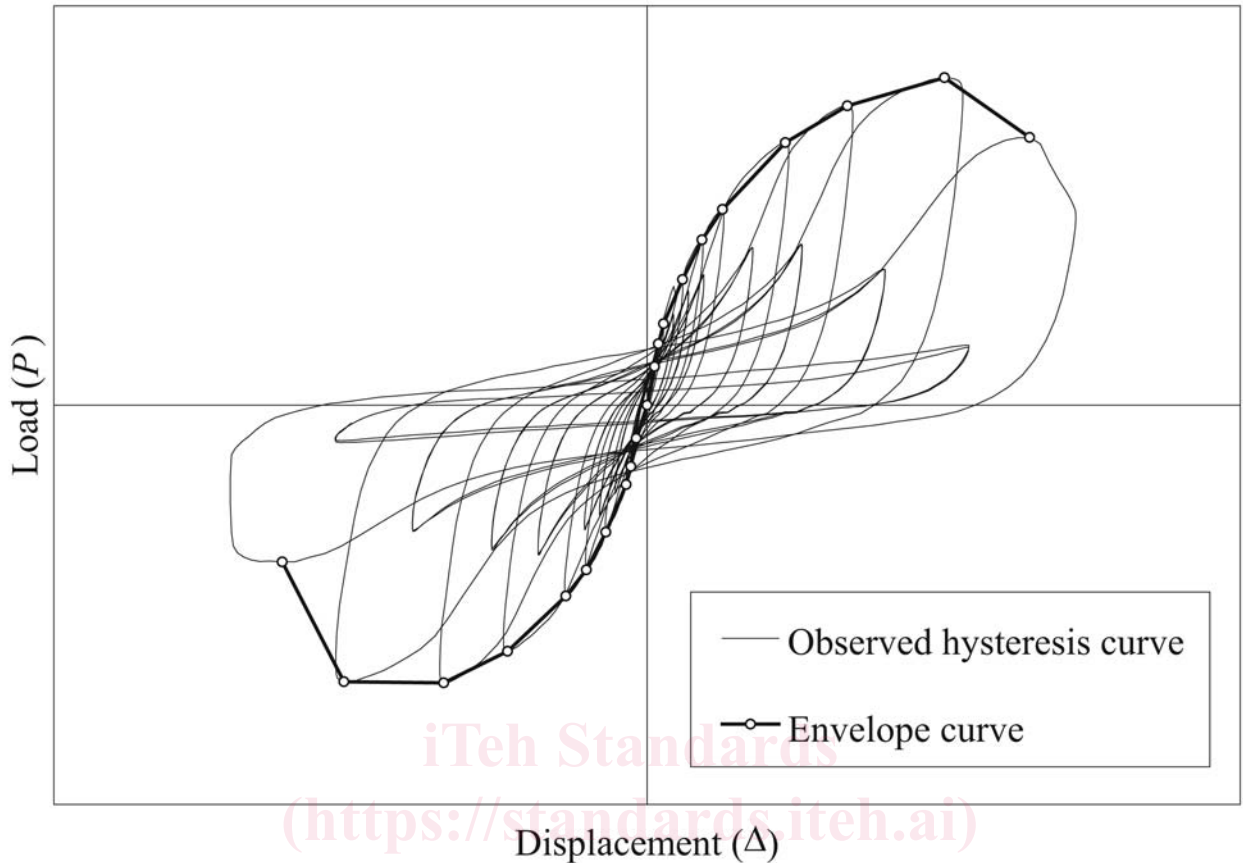

FIG. 1 Examples of Observed Hysteresis Curve and Envelope Curves for Method C (continued)

3.2.9 *limit state, n*—an event that demarks the two behavior states, at which time some structural behavior of the element or system is altered significantly.

3.2.10 *stabilized response, n*—load resistance that differs not more than 5 % between two successive cycles at the same amplitude.

3.2.11 *strength limit state* (see Fig. 2), *n*—the point on the envelope curve corresponding to the maximum absolute displacement Δ_{peak} at the maximum absolute load (P_{peak}) resisted by the assembly.

3.2.12 *ultimate displacement, cyclic* (Δ_u), *n*—the displacement corresponding to the failure limit state in cyclic test.

3.2.13 *ultimate displacement, monotonic* (Δ_m), *n*—the displacement corresponding to the failure limit state in monotonic test.

3.2.14 *yield limit state, n*—the point in the load-displacement relationship where the elastic shear stiffness of the assembly decreases 5 % or more. For assemblies with nonlinear ductile elastic response, the yield point ($\Delta_{yield}, P_{yield}$) is permitted to be determined using the EEEP curve (see 9.1.4).

4. Summary of Test Method

4.1 The elastic shear stiffness, shear strength and ductility of walls are determined by subjecting a wall assembly to full-reversal cyclic racking shear loads. This is accomplished by anchoring the bottom edge of the wall assembly to a rigid base and applying a force parallel to the top of the wall. The test

assembly is allowed to displace in its own plane. As the wall assembly is racked to specified displacement increments, the racking (shear) load and displacements are continuously measured (see 8.7).

5. Significance and Use

5.1 These test methods are intended to measure the performance of walls subjected to earthquake loads. Since these loads are cyclic, the loading process simulates the actions and their effects on the walls.

6. Wall Assembly

6.1 *General*—The typical wall assembly consists of a frame on which the elements comprising the wall, including the sheathing (or diagonal bracing members, if applicable) are placed. The elements shall be fastened to the frame in a manner to conform to 6.2. Elements used to construct wall assemblies may be varied to permit anticipated failure of selected elements.

6.2 *Connections*—The performance of framed walls is influenced by the type, spacing, and edge distance of fasteners attaching sheathing to framing and spacing of the shear connections and hold-down connectors to the rigid base. All of these connections shall be consistent with the types used in actual building connections.

6.3 *Frame Requirements*—The frame of the wall assembly shall consist of materials representative of those to be used in

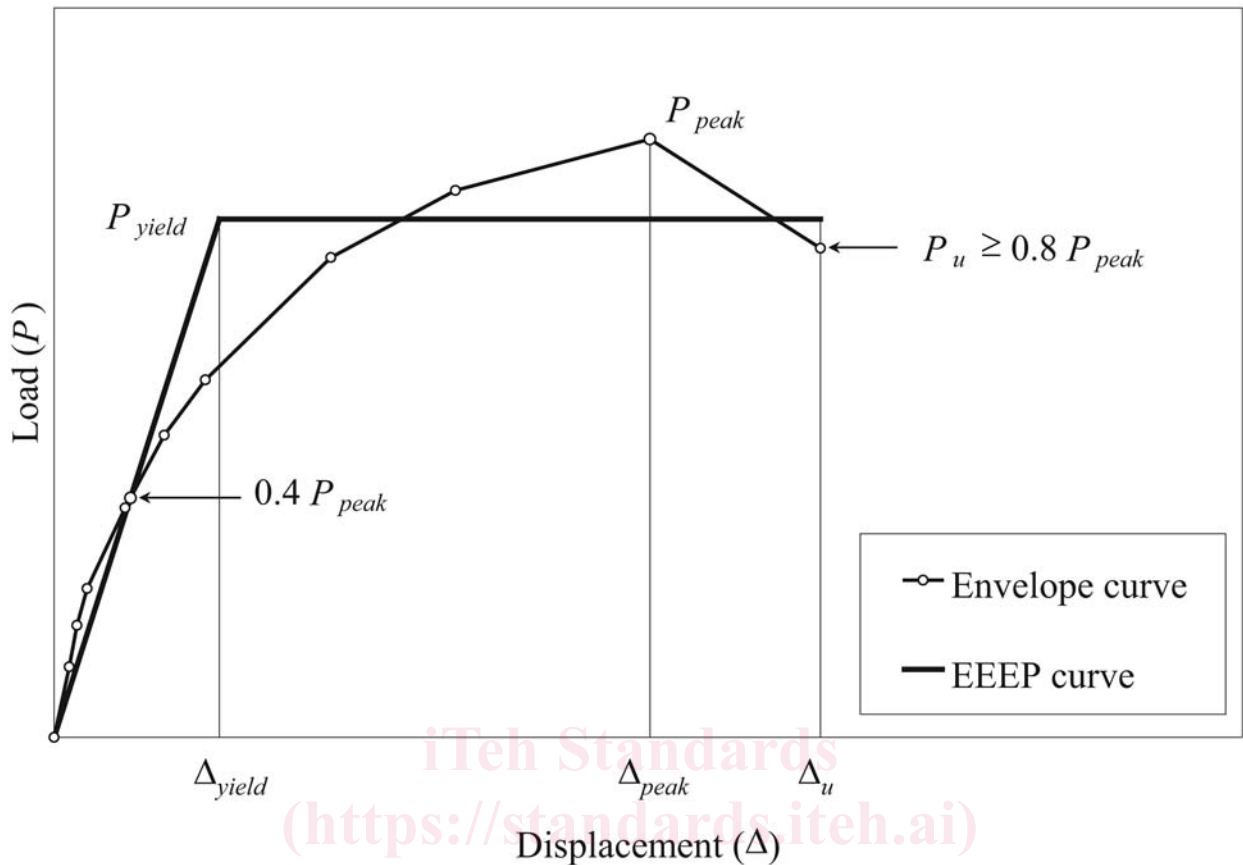

FIG. 2 Performance Parameters of Shear-Wall Assembly: (A) Last Point at $P_u \geq 0.8 P_{peak}$

the actual building construction. The connections of these members shall be consistent with those intended in actual building construction.

6.3.1 For wood framing members, record the species and grade of lumber used; moisture content of lumber at the time of fabrication and testing, if more than 24 h passes between these operations (see Test Methods D 4442, Method A or B; or D 4444, Method A or B); and specific gravity of the lumber (see Test Methods D 2395, Method A).

6.3.2 For steel or other metal framing members, record the material specifications and thickness.

6.4 *Structural Insulated Panel*—The panel is prefabricated assembly consisting of an insulating core of 1.5 in. (38 mm) minimum sandwiched between two facings. The assembly is constructed by attaching panels together and to top and bottom plates or tracks.

6.5 *Wall Size*—The wall assembly shall have a height and length or aspect (height/length) ratio that is consistent with intended use requirements in actual building construction (see Fig. 3).

7. Test Setup

7.1 The wall assembly shall be tested such that all elements and sheathing surfaces are observable. For assemblies such as framed walls with sheathing on both faces of framing or frameless structural insulated panels, the assemblies are dismantled after tests to permit observation of all elements. The

bottom of the wall shall be attached to a rigid base as specified in 6.2. The test apparatus shall support the wall assembly as necessary to prevent displacement from the plane of the wall, but in-plane displacement shall not be restricted.

8. Procedure

8.1 *Number of Tests*—A minimum of two identical wall assemblies shall be tested to determine the elastic shear stiffness and shear strength of a given construction. These values shall be calculated in accordance with 3.2 and 9.1. For analysis, the mean values are permitted to be based on the results of two walls if the parameters are within 10 % of each other. Otherwise, the mean values shall be based on the results of at least three walls.

8.2 Apply racking shear load horizontally in the plane of the wall to the top of the wall assembly (along the axis) (Fig. 4) using a programmable double-acting hydraulic actuator with load cell. The cyclic displacement of the actuator shall be controlled to follow a cyclic displacement procedure described in either 8.3 (Method A), 8.4 (Method B), or 8.5 (Method C).

8.3 *Method A (Sequential-Phased Displacement Procedure)*:

8.3.1 *Sequential Phased Displacement (SPD) Loading Protocol*—Displacement-controlled loading procedure that involves displacement cycles grouped in phases at incrementally increasing displacement levels. The cycles shall form either a sinusoidal wave or a triangular wave. The SPD loading

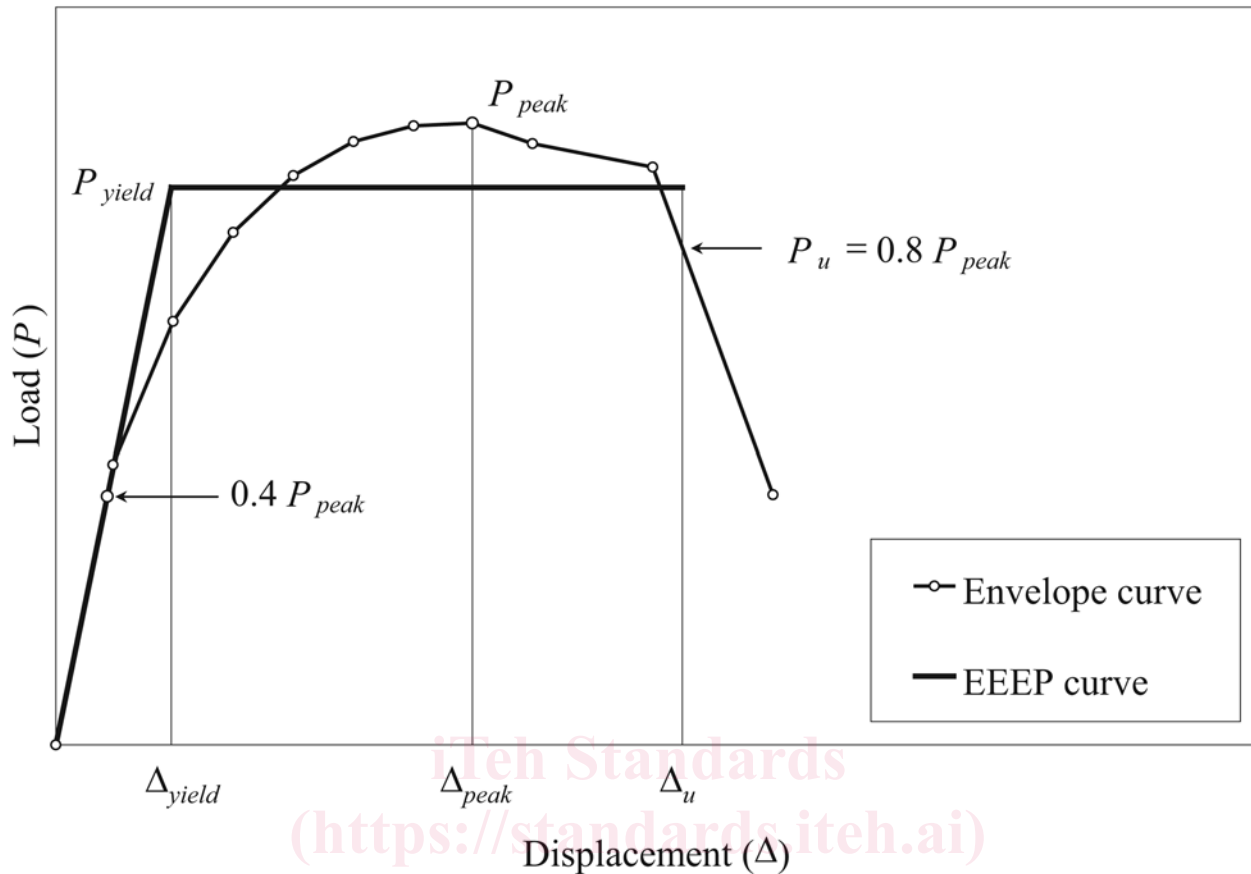

FIG. 2 Performance Parameters of Shear-Wall Assembly: (B) Last Point at $P_u = 0.8 P_{peak}$ (continued)

consists of two displacement patterns and is illustrated in Fig. 5. The first displacement pattern consists of three phases, each containing three fully-reversing cycles of equal amplitude, at displacements representing 25 %, 50 %, and 75 % of anticipated FME. The second displacement pattern is illustrated in Fig. 6. Each phase is associated with a respective displacement level and contains one initial cycle, three decay cycles, and a number of stabilization cycles. For nailed wood-frame shear walls, three stabilization cycles are sufficient to obtain a stabilized response. The amplitude of each consecutive decay cycle decreases by 25 % of the initial displacement.

8.3.2 The schedule of amplitude increments between the sequential phases is given in Table 1. The amplitude increments selected for the SPD procedure are based on the FME and the ductility factor, μ , determined from the static monotonic load test on an identical wall assembly in accordance with Practice E 564. To determine Δ_m and Δ_{yield} , it is permitted to compute EEEP curves, based on monotonic test data, in accordance with 9.1.4.

8.4 Method B (ISO 16670 Protocol):

8.4.1 ISO Displacement Schedule—Displacement-controlled loading procedure that involves displacement cycles grouped in phases at incrementally increasing displacement levels. The ISO loading schedule consists of two displacement patterns and is illustrated in Fig. 7. The first displacement pattern consists of five single fully reversed cycles at displacements of 1.25 %, 2.5 %, 5 %, 7.5 %, and 10 % of the ultimate

displacement Δ_m . The second displacement pattern consists of phases, each containing three fully reversed cycles of equal amplitude, at displacements of 20 %, 40 %, 60 %, 80 %, 100 %, and 120 % of the ultimate displacement Δ_m .

8.4.2 The sequence of amplitudes, which is given in Table 2, are a function of the mean value (where applicable) of the ultimate displacement (Δ_m) obtained from matched wall specimens in the monotonic tests in accordance with Practice E 564.

8.5 Method C (CUREE Basic Loading Protocol):

8.5.1 CUREE Basic Loading Protocol—Displacement-controlled loading procedure that involves displacement cycles grouped in phases at incrementally increasing displacement levels. The loading history starts with a series of initiation cycles at small amplitudes of equal magnitude. Further, each phase of the loading history consists of a primary cycle with amplitude expressed as a fraction (percent) of the reference deformation, Δ , and subsequent trailing cycles with amplitude of 75 % of the primary one.

NOTE 1—Normally, six initiation cycles of equal amplitude serve to check loading equipment, measurement devices, and the force-deformation response at small amplitudes.

8.5.2 The schedule of amplitude increments is given in Table 3 and is illustrated in Fig. 8. The reference deformation Δ shall be an estimate of the maximum displacement at which the load in a primary cycle has not yet dropped below $0.8 P_{peak}$. If the panel has not failed at the end of Phase 8 of Table 3, then

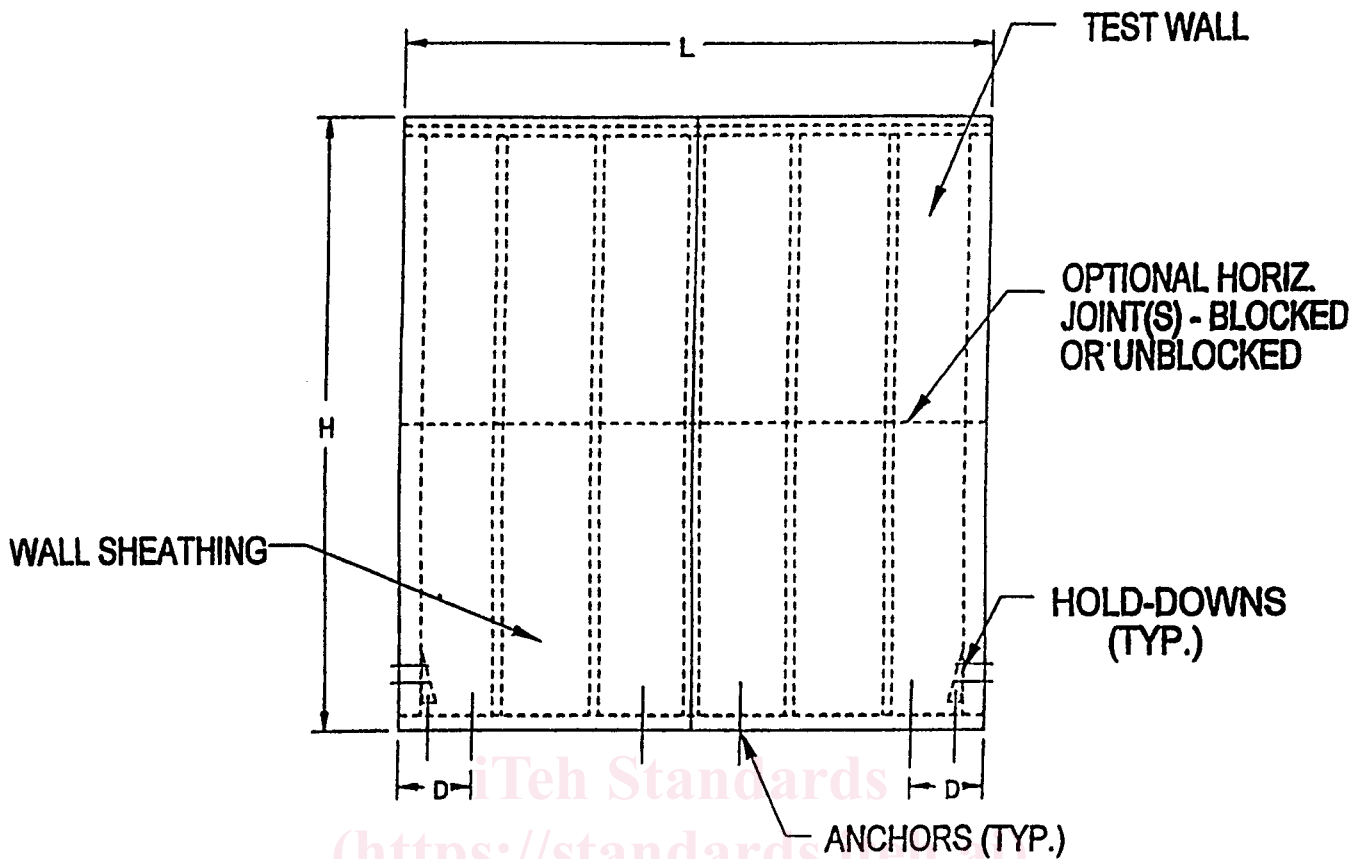

FIG. 3 Cyclic Load Shear Wall Test Specimen

additional phases shall be added. Each subsequent phase shall consist of a primary cycle with an increase in amplitude of α ($\alpha \leq 0.5$) over the previous primary cycle, and followed by two trailing cycles with amplitude of 75 % of the primary one.

8.6 The actuator displacement in Methods A, B, or C shall be controlled at either constant cyclic frequency or at a constant rate of displacement. The rate of displacement shall be between 0.04 and 2.5 in./s (1.0 and 63.5 mm/s). The cyclic frequency shall range from 0.2 to 0.5 Hz to avoid inertial effects of the mass of the wall and test fixture hardware during cyclic loading. The loading shall follow the corresponding procedure until the applied load diminishes more than 0.2 P_{peak} , that is, until the failure limit state occurs.

8.7 Displacements shall be measured with displacement measuring devices with a resolution of 0.005 in. (0.13 mm) or other suitable devices for continuously measuring displacement under cyclic loading conditions, at a minimum sampling rate of 100 readings per cycle. The following instrumentation shall be provided for measuring displacements, and hold-down connector forces when required:

8.7.1 Horizontal displacement of the wall at the top plate.

8.7.2 Vertical displacement of both end posts (uplift and compression) relative to the rigid base. The reference point for this measurement shall be on or immediately adjacent to the outside face of the end post.

8.7.3 Horizontal displacement of the bottom plate relative to the rigid base (lateral in-plane sliding).

8.7.4 Vertical displacement of the hold-down connectors relative to the end posts (deformation/fastener slip).

8.7.5 When specified, loads on the bolts fastening the hold-down connectors to the rigid base.

9. Calculation

9.1 Based on the observed hysteresis response curves, the envelope (positive and negative) curves are generated for each tested specimen. Performance parameters are first calculated for each envelope (positive and negative) and then averaged for each specimen. Performance parameters resulting from tests of identical wall assemblies are averaged (see 8.1). The following parameters are calculated:

9.1.1 *Shear Strength* (v_{peak}) lbf/ft (N/m)—The average of maximum absolute values of load per unit wall length resisted by the wall assembly in the negative and positive directions of displacement:

$$v_{peak} = \frac{P_{peak}}{L} \quad (1)$$

where:

P_{peak} = maximum absolute values of load resisted by the wall assembly in the given directions of displacement, lbf (or N), and

L = length of shear wall assembly, ft (m).

9.1.2 Secant shear modulus, G' , at $0.4 P_{peak}$ and at P_{peak} as follows: