Dentistry — Gypsum products

Médecine bucco-dentaire — Produits à base de gypse

iTeh STANDARD PREVIEW
(standards.iteh.ai)

[ISO 6873:2013](https://standards.iteh.ai/catalog/standards/sist/81a35073-80e4-40bf-ba51-18fd9d8ba990/iso-6873-2013)

<https://standards.iteh.ai/catalog/standards/sist/81a35073-80e4-40bf-ba51-18fd9d8ba990/iso-6873-2013>



iTeh STANDARD PREVIEW
(standards.iteh.ai)

ISO 6873:2013

<https://standards.iteh.ai/catalog/standards/sist/81a35073-80e4-40bf-ba51-18fd9d8ba990/iso-6873-2013>



COPYRIGHT PROTECTED DOCUMENT

© ISO 2013

All rights reserved. Unless otherwise specified, no part of this publication may be reproduced or utilized otherwise in any form or by any means, electronic or mechanical, including photocopying, or posting on the internet or an intranet, without prior written permission. Permission can be requested from either ISO at the address below or ISO's member body in the country of the requester.

ISO copyright office
Case postale 56 • CH-1211 Geneva 20
Tel. + 41 22 749 01 11
Fax + 41 22 749 09 47
E-mail copyright@iso.org
Web www.iso.org

Published in Switzerland

Contents

Page

Foreword	iv
Introduction	v
1 Scope	1
2 Normative references	1
3 Terms and definitions	1
4 Classification	1
5 Requirements	2
5.1 Quality.....	2
5.2 Fluidity at pouring time (Type 1 materials only).....	2
5.3 Setting time.....	2
5.4 Linear setting expansion.....	2
5.5 Fracture (Type 1 materials only).....	2
5.6 Compressive strength.....	2
5.7 Reproduction of detail.....	2
6 Testing — Generalities	3
6.1 Sampling.....	3
6.2 Test conditions.....	3
6.3 Mixing method.....	3
7 Test methods	3
7.1 Visual inspection.....	3
7.2 Fluidity at pouring time for Type 1 materials.....	3
7.3 Setting time.....	4
7.4 Linear setting expansion.....	7
7.5 Fracture.....	12
7.6 Compressive strength.....	12
7.7 Reproduction of detail.....	13
8 Packaging, marking and information to be supplied by the manufacturer	18
8.1 Packaging.....	18
8.2 Labelling.....	18
8.3 Instructions for use.....	19

Foreword

ISO (the International Organization for Standardization) is a worldwide federation of national standards bodies (ISO member bodies). The work of preparing International Standards is normally carried out through ISO technical committees. Each member body interested in a subject for which a technical committee has been established has the right to be represented on that committee. International organizations, governmental and non-governmental, in liaison with ISO, also take part in the work. ISO collaborates closely with the International Electrotechnical Commission (IEC) on all matters of electrotechnical standardization.

International Standards are drafted in accordance with the rules given in the ISO/IEC Directives, Part 2.

The main task of technical committees is to prepare International Standards. Draft International Standards adopted by the technical committees are circulated to the member bodies for voting. Publication as an International Standard requires approval by at least 75 % of the member bodies casting a vote.

Attention is drawn to the possibility that some of the elements of this document may be the subject of patent rights. ISO shall not be held responsible for identifying any or all such patent rights.

Specific qualitative and quantitative requirements for freedom from biological hazard are not included in this International Standard but it is recommended that, in assessing possible biological hazards, reference should be made to ISO 10993-1 and ISO 7405.

ISO 6873 was prepared by Technical Committee ISO/TC 106, *Dentistry*, Subcommittee SC 2, *Prosthetic materials*.

This third edition cancels and replaces the second edition (ISO 6873:1998) of which [Clause 4](#) and subclauses [5.4](#) and [8.2](#) have been technically revised. An alternative design for the extensometer used to measure setting expansion is included.

<https://standards.iteh.ai/catalog/standards/sist/81a35073-80e4-40bf-ba51-18fd9d8ba990/iso-6873-2013>

Introduction

This revision was necessary because gypsum products have been marketed since the last edition of ISO 6873 was published, which have properties (required for newly introduced dental technology) for which the requirements set in that edition were not appropriate. In this edition the classification has been altered to take this into account and in so doing, requirements have been set appropriately. In addition there was concern that Type 4 dental stone used for CAD/CAM models should not produce significant setting expansion at times beyond the 2 h period at which setting expansion was measured and a requirement had been set. In this edition the setting expansion for Type 4 dental stone is measured at 24 h as well.

iTeh STANDARD PREVIEW (standards.iteh.ai)

[ISO 6873:2013](https://standards.iteh.ai/catalog/standards/sist/81a35073-80e4-40bf-ba51-18fd9d8ba990/iso-6873-2013)

<https://standards.iteh.ai/catalog/standards/sist/81a35073-80e4-40bf-ba51-18fd9d8ba990/iso-6873-2013>

iTeh STANDARD PREVIEW
(standards.iteh.ai)

ISO 6873:2013

<https://standards.iteh.ai/catalog/standards/sist/81a35073-80e4-40bf-ba51-18fd9d8ba990/iso-6873-2013>

Dentistry — Gypsum products

1 Scope

This International Standard gives a classification of, and specifies requirements for, gypsum products used for dental purposes such as making oral impressions, moulds, casts, dies or model bases, and mounting models. It specifies the test methods to be employed to determine compliance with these requirements. It also includes requirements for the labelling of packaging and for adequate instructions to accompany each package.

This International Standard does not apply to dental bone graft substitutes composed of calcium sulfate hemihydrate (or gypsum).

2 Normative references

The following referenced documents are indispensable for the application of this document. For dated references, only the edition cited applies. For undated references, the latest edition of the referenced document (including any amendments) applies.

ISO 1302, *Geometrical Product Specifications (GPS) — Indication of surface texture in technical product documentation*

ISO 1942, *Dentistry — Vocabulary*

ISO 3696:1987, *Water for analytical laboratory use — Specification and test methods*

ISO 8601, *Data elements and interchange formats — Information interchange — Representation of dates and times*

ISO 15223-1, *Medical devices — Symbols to be used with medical device labels, labelling and information to be supplied — Part 1: General requirements*

3 Terms and definitions

For the purposes of this document, the terms and definitions given in ISO 1942 and the following apply.

3.1

gypsum product

dental product composed essentially of a hemihydrate of calcium sulfate and any necessary modifiers

Note 1 to entry: Colouring matter and flavouring, if present, are regarded as necessary modifiers.

4 Classification

The five types of gypsum product used in dentistry are classified in accordance with this International Standard as follows:

- a) **Type 1:** Dental plaster for impressions;
- b) **Type 2:** Dental plaster for mounting (Class 1) and for models (Class 2);
- c) **Type 3:** Dental stone for models;
- d) **Type 4:** Dental stone (high strength, low expansion) for dies, model bases and CAD/CAM dies;

- e) **Type 5:** Dental stone (high strength, high expansion) for dies when this degree of expansion is necessary for shrinkage compensation of some materials used in dental restoration.

5 Requirements

5.1 Quality

When tested according to 7.1, the powder shall be uniform and free from foreign matter and lumps. When mixed according to the manufacturer's instructions the product shall produce a homogeneous mix.

5.2 Fluidity at pouring time (Type 1 materials only)

When tested according to 7.2 at a pouring time of 1,25 min, the fluidity of type 1 materials shall be equal to or greater than 70 mm.

5.3 Setting time

When tested according to 7.3, the setting time of type 1 materials shall be in the range of 2,5 min to 5,0 min and the setting time of all material types shall be within 20 % of the value claimed by the manufacturer in 8.2.1 h) or 8.2.2 h), whichever is appropriate for the packaging in which the product is supplied. If the manufacturer claims a range of setting time, then the midpoint of this range is taken as the value claimed by the manufacturer.

5.4 Linear setting expansion

When tested according to 7.4, the linear setting expansion shall be within the range listed in Table 1.

Table 1 — Linear setting expansion and compressive strength

Type	Linear setting expansion %				Compressive strength MPa	
	2 h		24 h		1 h	
	min.	max.	min.	max.	min.	max.
1	0,00	0,15	-	-	4,0	8,0
2 (Class 1)	0,00	0,05	-	-	9,0	-
2 (Class 2)	0,06	0,30	-	-	9,0	-
3	0,00	0,20	-	-	20,0	-
4	0,00	0,15	0,00	0,18	35,0	-
5	0,16	0,30	-	-	35,0	-

5.5 Fracture (Type 1 materials only)

When tested according to 7.5, Type 1 impression plaster shall break with a clean fracture and be readily reassembled to form the shape and size of the original unbroken specimen.

5.6 Compressive strength

When tested according to 7.6, the compressive strength shall meet the requirement(s) of Table 1.

5.7 Reproduction of detail

Types 1 and 2: When tested according to 7.7, groove c in Figure 6 shall be reproduced.

Types 3, 4 and 5: When tested according to 7.7, groove a in Figure 6 shall be reproduced.

6 Testing — Generalities

6.1 Sampling

Select the material for testing from one lot that has been produced for retail and that is not beyond its expiry date [8.2.1 b) or 8.2.2 b)], whichever is appropriate for the packaging in which the product is supplied]. Do not use powder from previously opened, broken or damaged containers.

6.2 Test conditions

Carry out all mixing and testing of the dental gypsum product at (23 ± 2) °C and (50 ± 10) % relative humidity. Ensure that all apparatus and instruments used in mixing and testing are clean, dry and free from particles of gypsum. Before testing begins, hold material and test apparatus at the test temperature for a period of time that is sufficient to equilibrate with this temperature.

NOTE A minimum storage period of 15 h is recommended.

6.3 Mixing method

Mix by one of the methods (hand or mechanical) specified by the manufacturer in the instructions (see 8.3), using water, which meets the requirements of ISO 3696, Grade 3.

7 Test methods

iTeh STANDARD PREVIEW
(standards.iteh.ai)

7.1 Visual inspection

Carry out visual inspection without magnification to determine compliance with the requirements given in 5.1, 5.5 and 5.7 (unless as stated otherwise, as in 7.7).

Determine compliance with the requirements given in Clause 8 for packaging, marking and information supplied by the manufacturer.

7.2 Fluidity at pouring time for Type 1 materials

7.2.1 Apparatus

7.2.1.1 Cylindrical mould, constructed from a corrosion-resistant, non-absorbent material, having a length of $(50,0 \pm 0,1)$ mm and an inside diameter of $(35,0 \pm 0,1)$ mm. Clean and dry.

7.2.1.2 Glass plate, flat and smooth, with sides of length at least 100 mm. Clean and dry.

7.2.1.3 Means of measuring lengths from 35 mm to 100 mm, for measuring the major and minor diameters of the slumped mix to the nearest millimetre.

7.2.2 Procedure

Rest the glass plate on a surface that is free of vibration. Place the mould upright on the centre of the plate.

Add $(100,0 \pm 0,1)$ g of the sample to the manufacturer's recommended quantity of water (ISO 3696, Grade 3) dispensed to an accuracy of 0,1 ml to a mixing bowl and mix as described in 6.3.

Completely fill the mould and level off the mixed material so that it is flush with the top of the mould. At 1,25 min after the start of mixing, lift the mould vertically from the plate at a rate of approximately 10 mm/s and allow the mix to slump or spread over the plate. One minute after the mould is lifted, measure the major and minor axes of the slumped material to the nearest millimetre. Record the average of these two diameters as the fluidity at the pouring time.

7.2.3 Evaluation

Carry out the test twice. If both average values meet the requirement given in 5.2, then the product meets the requirement for fluidity. If neither meets this requirement, then the product fails. If one average value meets the requirement given in 5.2, and the other fails, carry out three more tests. If all three of these average values meet the requirement given in 5.2, the product meets the requirement for fluidity. Otherwise it fails.

7.3 Setting time

7.3.1 Apparatus

7.3.1.1 Needle penetrometer, an example of which is shown in [Figure 1](#), meeting the following requirements:

- a) Penetrometer needle (1), 50 mm long, of circular cross-section, with a diameter of $(1,00 \pm 0,05)$ mm and a squared end.
- b) Rod (2), of approximate dimensions 270 mm long and 10 mm in diameter.
- c) Additional (compensating) weight (3).
- d) The total mass of all the parts that move with the rod shall be (300 ± 1) g.
- e) Scale (4), graduated in millimetres.
- f) Base-plate (5) of plate glass, measuring about 100 mm \times 100 mm.

ITeH STANDARD PREVIEW
(standards.iteh.ai)
<https://standards.iteh.ai/catalog/standards/sist/81a35073-80e4-40bf-ba51-18fd9d8ba990/iso-6873-2013>

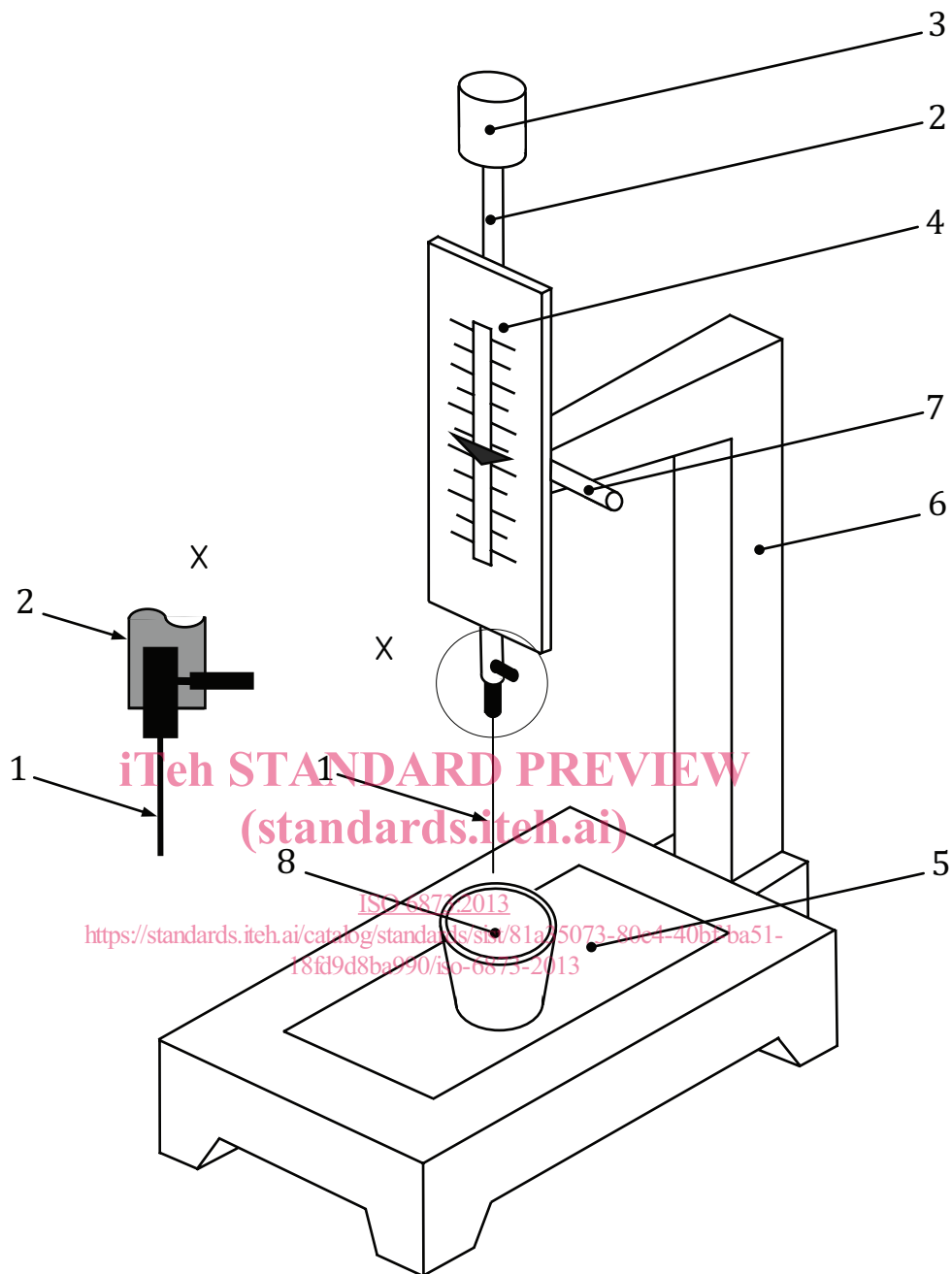
**Key**

- | | | | |
|---|----------------------------------|---|--------------------------------|
| 1 | Needle | 5 | Base plate |
| 2 | Rod | 6 | Stand |
| 3 | Additional (compensating) weight | 7 | Scale adjustment locking screw |
| 4 | Scale | 8 | Mould |

Figure 1 — Example of needle penetrometer

7.3.1.2 Ring mould, constructed from a corrosion-resistant, non-absorbent material. There are two alternatives.

7.3.1.2.1 Large conical mould, with an inside diameter of 70 mm at the top and 60 mm at the base, and a height of 40 mm.