

INTERNATIONAL
STANDARD

ISO
5402-2

IULTCS/IUP 39-2

First edition
2015-09-15

**Leather — Determination of flex
resistance —**

**Part 2:
Vamp flex method**

Cuir — Détermination de la résistance à la flexion —

Partie 2: Méthode de flexion d'empeigne

**iTeh STANDARD PREVIEW
(standards.iteh.ai)**

ISO 5402-2:2015

<https://standards.iteh.ai/catalog/standards/sist/dcab8eeb-1f87-4e6f-89f5-68a0a70c0817/iso-5402-2-2015>



Reference numbers
ISO 5402-2:2015(E)
IULTCS/IUP 39-2:2015(E)

© ISO 2015

iTeh STANDARD PREVIEW (standards.iteh.ai)

ISO 5402-2:2015

<https://standards.iteh.ai/catalog/standards/sist/dcab8eeb-1f87-4e6f-89f5-68a0a70c0817/iso-5402-2-2015>



COPYRIGHT PROTECTED DOCUMENT

© ISO 2015, Published in Switzerland

All rights reserved. Unless otherwise specified, no part of this publication may be reproduced or utilized otherwise in any form or by any means, electronic or mechanical, including photocopying, or posting on the internet or an intranet, without prior written permission. Permission can be requested from either ISO at the address below or ISO's member body in the country of the requester.

ISO copyright office
Ch. de Blandonnet 8 • CP 401
CH-1214 Vernier, Geneva, Switzerland
Tel. +41 22 749 01 11
Fax +41 22 749 09 47
copyright@iso.org
www.iso.org

Contents

	Page
Foreword	iv
1 Scope	1
2 Normative references	1
3 Principle	1
4 Apparatus	1
5 Sampling and sample preparation	4
6 Procedure	4
7 Test report	5
Annex A (informative) Sources of apparatus	6

iTeh STANDARD PREVIEW (standards.iteh.ai)

[ISO 5402-2:2015](https://standards.iteh.ai/catalog/standards/sist/dcab8eeb-1f87-4e6f-89f5-68a0a70c0817/iso-5402-2-2015)

<https://standards.iteh.ai/catalog/standards/sist/dcab8eeb-1f87-4e6f-89f5-68a0a70c0817/iso-5402-2-2015>

Foreword

ISO (the International Organization for Standardization) is a worldwide federation of national standards bodies (ISO member bodies). The work of preparing International Standards is normally carried out through ISO technical committees. Each member body interested in a subject for which a technical committee has been established has the right to be represented on that committee. International organizations, governmental and non-governmental, in liaison with ISO, also take part in the work. ISO collaborates closely with the International Electrotechnical Commission (IEC) on all matters of electrotechnical standardization.

The procedures used to develop this document and those intended for its further maintenance are described in the ISO/IEC Directives, Part 1. In particular the different approval criteria needed for the different types of ISO documents should be noted. This document was drafted in accordance with the editorial rules of the ISO/IEC Directives, Part 2 (see www.iso.org/directives).

Attention is drawn to the possibility that some of the elements of this document may be the subject of patent rights. ISO shall not be held responsible for identifying any or all such patent rights. Details of any patent rights identified during the development of the document will be in the Introduction and/or on the ISO list of patent declarations received (see www.iso.org/patents).

Any trade name used in this document is information given for the convenience of users and does not constitute an endorsement.

For an explanation on the meaning of ISO specific terms and expressions related to conformity assessment, as well as information about ISO's adherence to the WTO principles in the Technical Barriers to Trade (TBT) see the following URL: [Foreword - Supplementary information](http://Foreword - Supplementary information (standards.iteh.ai))

ISO 5402-2, formerly ISO 22288, was prepared by the Physical Test Commission of the International Union of Leather Technologists and Chemists Societies (IUP Commission, IULTCS) in collaboration with the European Committee for Standardization (CEN) Technical Committee CEN/TC 289, *Leather*, the secretariat of which is held by UNI, in accordance with the Agreement on technical cooperation between ISO and CEN (Vienna Agreement). It was published as EN 13335.

It is based on IUP 39 published in *J. Soc. Leather Tech. Chem.*, **84** (7), p. 381, 2000, and declared an official method of the IULTCS in March 2001. The title was changed, [Clause 4](#) revised in 2013, and the standard re-numbered as ISO 5402-2.

IULTCS, originally formed in 1897, is a world-wide organization of professional leather societies to further the advancement of leather science and technology. IULTCS has three Commissions, which are responsible for establishing international methods for the sampling and testing of leather. ISO recognizes IULTCS as an international standardizing body for the preparation of test methods for leather.

This first edition cancels and replaces ISO 22288:2006 which has been technically revised.

ISO 5402 consists of the following parts, under the general title *Leather — Determination of flex resistance*:

- *Part 1: Flexometer method*
- *Part 2: Vamp flex method*

Leather — Determination of flex resistance —

Part 2: Vamp flex method

1 Scope

This part of ISO 5402 specifies a method for determining the wet or dry flex resistance of leather and finishes applied to leather. It is applicable to all types of leather below 3,0 mm in thickness.

2 Normative references

The following documents, in whole or in part, are normatively referenced in this document and are indispensable for its application. For dated references, only the edition cited applies. For undated references, the latest edition of the referenced document (including any amendments) applies.

ISO 2418, *Leather — Chemical, physical and mechanical and fastness tests — Sampling location*

ISO 2419, *Leather — Physical and mechanical tests — Sample preparation and conditioning*

ISO 3696, *Water for analytical laboratory use — Specification and test methods*

3 Principle

A test piece is folded with the surface to be tested outwards over two inverted “V” shaped clamps. Relative movement of the clamps flexes the sample producing one downward crease surrounded by four upward creases. The test piece is examined periodically for damage.

4 Apparatus

4.1 **Test machine**, incorporating the following.

4.1.1 **Two inverted “V” shaped clamps** (Figures 1 and 2), aligned parallel to one another, centred on the same axis and with a minimum separation between the clamps of $(9,5 \pm 1,0)$ mm.

Each clamp shall have two parts.

4.1.1.1 An outer part comprising a “V” form with an internal angle of $(40 \pm 1)^\circ$ and a truncated tip radius of $(6,4 \pm 0,5)$ mm.

4.1.1.2 An inner part having the shape and size that shall complement the outer part.

4.1.2 **A means of applying a simple harmonic reciprocating motion** between the two clamps, to move them apart by $(19,0 \pm 1,5)$ mm and return them to the minimum separation (4.1.1) at a rate of oscillation of (300 ± 30) cycles/min.

4.1.3 **Counter**, to indicate the number of complete cycles.

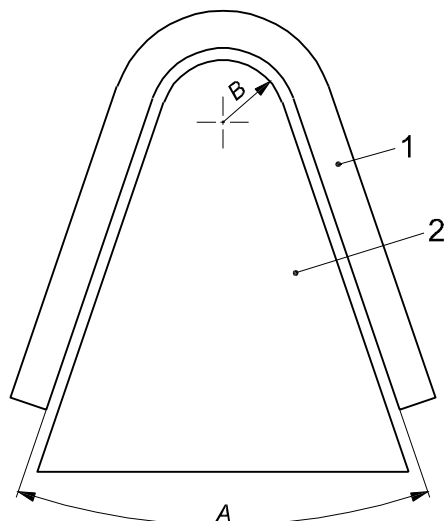

Key

- 1 clamp, outer part
- 2 clamp, inner part
- A internal angle, $(40 \pm 1)^\circ$
- B radius, $(6,4 \pm 0,5)$ mm

Figure 1 — Inverted “V” shaped clamp
(standards.iteh.ai)

ISO 5402-2:2015

<https://standards.iteh.ai/catalog/standards/sist/dcab8eeb-1f87-4e6f-89f5-68a0a70c0817/iso-5402-2-2015>

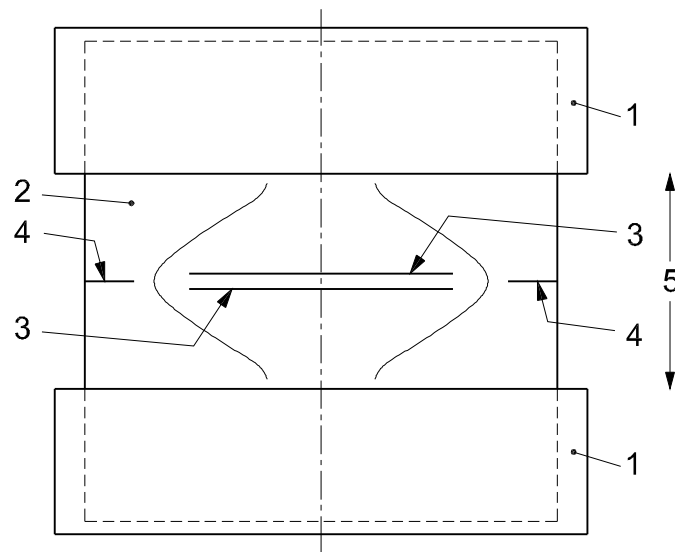

a) Plan view — Crease pattern formed by flexing



b) Side view — Crease pattern in example test piece

Key

- 1 inverted "V" shaped clamps
- 2 test piece
- 3 folds with surface to be tested inwards
- 4 folds with surface to be tested outwards
- 5 oscillation (9,5 mm to 19,0 mm)

Figure 2 — Crease patterns

4.2 Press knife, conforming to the requirements of ISO 2419, the inner wall of which is a square of side $64 \text{ mm} \pm 1 \text{ mm}$.

4.3 Magnifier, with a magnification of four to six times.

4.4 Distilled or deionized water, conforming to the requirements of grade 3 of ISO 3696.

5 Sampling and sample preparation

5.1 Sample in accordance with ISO 2418. Cut four test pieces parallel to the backbone and four test pieces perpendicular to the backbone by applying the press knife (4.2) to the surface to be tested. Use two test pieces parallel to and two test pieces perpendicular to the backbone for dry tests and two test pieces parallel to and two test pieces perpendicular to the backbone for wet tests.

If there is a requirement for more than two hides or skins to be tested in one batch, then only two samples in each direction need be taken from each hide or skin, giving one sample in each direction for both dry and wet, provided that the overall total is not less than four test pieces in each direction.

5.2 For dry flex testing, condition the test pieces in accordance with ISO 2419 and perform the test in the conditioned atmosphere.

5.3 For wet flex testing, the test pieces can be wetted by rubbing approximately 1 ml of distilled or deionized water into the flesh surface of the leather. The wetting should be repeated every 25,000 flexes during the test. Carry out wet flexing without delay.

6 Procedure

ISO 5402-2:2015

<https://standards.iteh.ai/catalog/standards/sist/dcab8eeb-1f87-4e6f-89f5->

6.1 Remove the upper parts of the clamps (4.1.1) and adjust the test machine so that the clamps are at their maximum separation.

6.2 Fold the test piece evenly over the "V" shaped clamps with the surface to be tested uppermost and hold in place by replacing the upper parts of the clamps, ensuring that there is no slack in the test piece. Position two test pieces so that the direction of the backbone is along the axis of movement of the clamps and two so that it is perpendicular to the axis.

6.3 Slowly move the clamps together and observe the test pieces to ensure that the centre of each test piece folds downwards (Figure 2). If this is not the case, apply gentle pressure to the centre of the ridge as the clamps move together to make a downward fold form.

6.4 Run the machine for the required number of flex cycles selected from the following list:

- Dry flex: 50 000; 100 000; 250 000; 500 000; 1 000 000 cycles;
- Wet flex: 50 000; 100 000 cycles.

In addition to the above inspection points, remove the wet test pieces from the machine every 25 000 cycles and examine them for spue before re-wetting and replacing in the test machine.

NOTE Other inspection points are considered if required.

6.5 Stop the test machine and remove the test piece. Examine visually in good light using the naked eye and with the magnifier (4.3). Examine the test piece with it both lying flat and folded. Record any damage

in the flexed area, ignoring damage in the clamped area. Cut through the flexed area if required to assist identification of loose leather structure.

Cutting through the test piece damages it too severely to allow further testing and may only be carried out after the final inspection.

The damage can include the following:

- a) creasing in the central inward fold;
- b) cracking in the central inward fold;
- c) cracking in the outward folds;
- d) delamination or flaking of the surface finish;
- e) cracking extending to the edge of the test piece;
- f) onset of appearance of spue (wet flex only) when examined both wet (immediately after completion of the test) and after allowing to completely dry at standard room temperature as prescribed in ISO 2419.

6.6 If required, replace the test piece in the clamps using the marks produced by the clamps as a guide to ensure that the test piece is returned to its original position in the clamps.

6.7 Restart the machine and continue to the next required number of cycles. Repeat the inspection given in [6.5](#).

6.8 Repeat [6.6](#) and [6.7](#) if required for other numbers of flex cycles.

6.9 After the final wet inspection, allow to completely dry at standard room temperature as prescribed in ISO 2419.

NOTE The actual number of cycles chosen depends on the specification, the end use of the leather, and the expected performance.

7 Test report

The test report shall include the following:

- a) a reference to this part of ISO 5402, i.e. ISO 5402-2;
- b) full details for identification of the sample;
- c) whether the leather was tested wet or dry;
- d) the number of flex cycles and damage at each inspection stage;
- e) the standard atmosphere used for conditioning and testing as given in ISO 2419;
- f) any deviations from the method specified in this part of ISO 5402.