International Standard



1002

INTERNATIONAL ORGANIZATION FOR STANDARDIZATION • МЕЖДУНАРОДНАЯ ОРГАНИЗАЦИЯ ПО СТАНДАРТИЗАЦИИ • ORGANISATION INTERNATIONALE DE NORMALISATION

Rolling bearings — Airframe bearings — Characteristics, boundary dimensions, tolerances, static load ratings

Roulements — Roulements utilisés dans la structure des aéronefs — Caractéristiques, dimensions d'encombrement, tolérances, charges statiques de base

First edition — 1983-06-01

iTeh STANDARD PREVIEW
(standards.iteh.ai)

[ISO 1002:1983](https://standards.iteh.ai/catalog/standards/sist/323bf6ed-db68-49b2-b950-e23554399508/iso-1002-1983)

<https://standards.iteh.ai/catalog/standards/sist/323bf6ed-db68-49b2-b950-e23554399508/iso-1002-1983>

UDC 621.822.6/.8 : 629.7.02

Ref. No. ISO 1002-1983 (E)

Descriptors : bearings, rolling bearings, airframe bearings, characteristics, dimensions, dimensional tolerances, static loads.

Foreword

ISO (the International Organization for Standardization) is a worldwide federation of national standards institutes (ISO member bodies). The work of developing International Standards is carried out through ISO technical committees. Every member body interested in a subject for which a technical committee has been set up has the right to be represented on that committee. International organizations, governmental and non-governmental, in liaison with ISO, also take part in the work.

Draft International Standards adopted by the technical committees are circulated to the member bodies for approval before their acceptance as International Standards by the ISO Council.

International Standard ISO 1002 was developed by Technical Committee ISO/TC 4, *Rolling bearings*, and was circulated to the member bodies in December 1981.

It has been approved by the member bodies of the following countries :

Austria	India	Romania
Brazil	Ireland	Spain
Canada	Italy	Sweden
China	Japan	Switzerland
Czechoslovakia	Korea, Dem. P. Rep. of	United Kingdom
Egypt, Arab Rep. of	Korea, Rep. of	USA
Germany, F.R.	Poland	USSR

The member body of the following country expressed disapproval of the document on technical grounds :

France

This International Standard cancels and replaces ISO Recommendation R 1002-1969, of which it constitutes a technical revision.

Contents

Page

1	Scope and field of application	1
2	References	1
3	Symbols	2
4	Essential characteristics	4
5	Seals and shields	4
6	Protection against corrosion	4
7	Boundary dimensions	4
8	Tolerances	4
9	Basic static radial load ratings	4
10	Dimensions and tolerances — Tables	5
10.1	Index to tables	5
10.2	Dimension tables — Metric series	5
10.3	Tolerance and radial clearance tables — Metric series	8
10.4	Dimension tables — Inch series	9
10.5	Tolerance and radial clearance tables — Inch series	14
Annex	Permissible load	17

iTeh STANDARD PREVIEW

(standard.iTech.ai)

ISO 1002:1983
<https://standards.iteh.ai/catalog/standards/sist/323b16ed-db68-49b2-b950-e2354399568/iso-1002-1983>

iTeh STANDARD PREVIEW

This page intentionally left blank
(standards.iteh.ai)

[ISO 1002:1983](#)

<https://standards.iteh.ai/catalog/standards/sist/323bf6ed-db68-49b2-b950-e23554399508/iso-1002-1983>

Rolling bearings — Airframe bearings — Characteristics, boundary dimensions, tolerances, static load ratings

iTeh STANDARD PREVIEW (standards.iteh.ai)

1 Scope and field of application

This International Standard specifies characteristics, boundary dimensions, tolerances and static load ratings of rolling bearings, other than tapered roller bearings, used in airframes, as distinct from those used in connection with power plants, auxiliary drives, accessories and instruments in aircraft. For the purposes of this International Standard, an airframe is defined as the general structure of an aircraft and includes its control surfaces, all flaps and doors and their respective mechanisms. Both metric and inch series bearings are included because of established usage in the aircraft industry.

The bearings included in this International Standard are usually full complement bearings (no cage and full complement of rolling elements) with basically cylindrical bore and outside surface and are sealed or shielded. The bearings have an extended inner ring, except for those in table 3. The bearings are normally supplied adequately charged with suitable grease, and the external surfaces of the bearings may be protected by the same grease.

In view of the design requirements, it is generally not possible to select standard bearings from ISO 15 for airframe applications, but for metric series bearings the boundary dimensions given in ISO 15 have been used where possible.

The fact that a bearing is not included in this International Standard does not exclude the possibility that it may be used to advantage in airframe applications.

2 References

ISO 15, *Rolling bearings — Radial bearings — Boundary dimensions — General plan.*

ISO 76, *Rolling bearings — Static load ratings.*

ISO 1132, *Rolling bearings — Tolerances — Definitions.*

3 Symbols

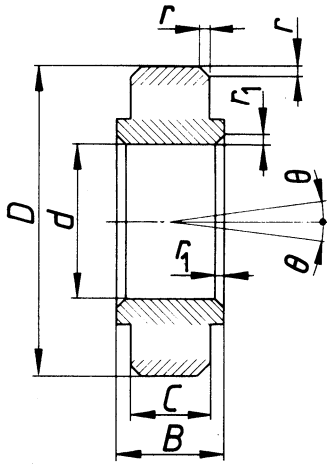

(angle θ applies only to self-aligning bearings)

Figure 1

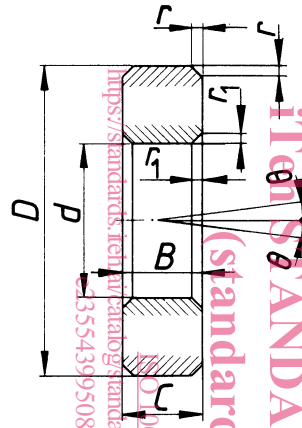

Figure 2

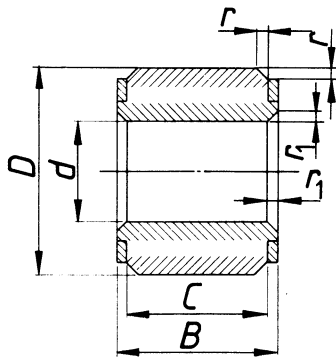

Figure 3

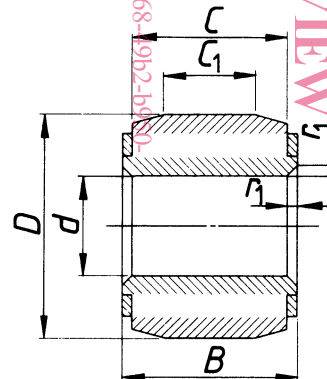

Figure 4

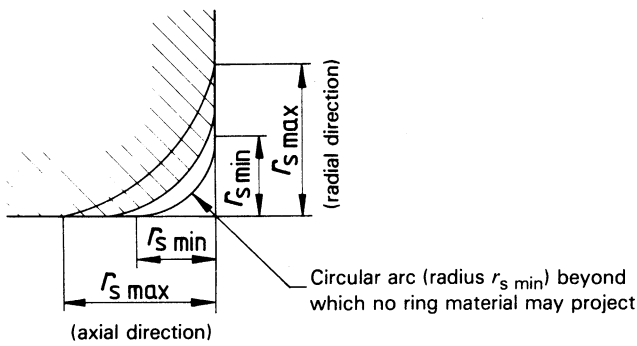

Figure 5

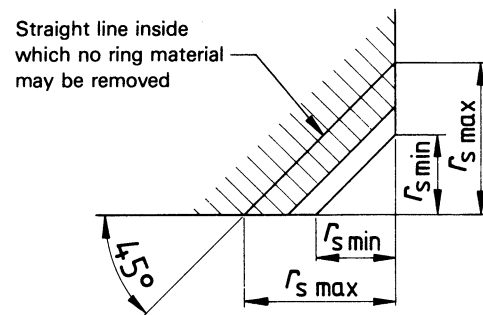

Figure 6

NOTE — Figures 5 and 6 apply equally to chamfers denoted as r (shown) and as r_1 .

d	= bearing bore diameter, nominal
Δ_{dmp}	= single plane mean bore diameter deviation
Δ_{ds}	= deviation of a single bore diameter
V_{dp}	= bore diameter variation in a single radial plane
D	= bearing outside diameter, nominal
Δ_{Dmp}	= single plane mean outside diameter deviation
Δ_{Ds}	= deviation of a single outside diameter
V_{Dp}	= outside diameter variation in a single radial plane
C	= outer ring width, nominal
Δ_{Cs}	= deviation of a single width of the outer ring
V_{Cs}	= outer ring width variation
C_1	= nominal width of track contact (cylindrical)
C_{1s}	= single width of track contact (cylindrical)
B	= inner ring width, nominal
Δ_{Bs}	= deviation of a single width of the inner ring
V_{Bs}	= inner ring width variation
r	= outer ring radial and axial chamfer dimension (Nominal values are not given in this International Standard; only minimum ($r_{s \min}$) and maximum ($r_{s \max}$) are listed in tables.)
r_s	= outer ring single chamfer dimension
r_1	= inner ring radial and axial chamfer dimension (Nominal values are not given in this International Standard; only minimum ($r_{1s \min}$) and maximum ($r_{1s \max}$) are listed in tables.)
r_{1s}	= inner ring single chamfer dimension
K_{ia}	= radial runout of assembled bearing inner ring
K_{ea}	= radial runout of assembled bearing outer ring
S_{ia}	= assembled bearing inner ring face runout with raceway (groove)
θ	= angular displacement permissible between inner and outer ring axes of a self-aligning bearing
C_{or}	= basic static radial load rating

NOTE — Definitions of tolerance terms are given in ISO 1132.

4 Essential characteristics

The lubricant and seals shall be capable of withstanding temperatures in the range of -55 to $+120$ °C without losing their effectiveness.

NOTE — The operational conditions may necessitate wider extremes of temperature, in which case other greases and/or sealing materials may be required.

Bearings shall be capable of withstanding repeated loads of variable intensity, normally without making a complete revolution.

NOTE — The bearings are generally made with an extended inner ring in order to simplify bearing installation by making the addition of washers unnecessary.

5 Seals and shields

Bearings in tables 1 to 6, 11, 13, 14 and 16 shall be sealed or shielded, bearings in tables 12, 15, 17 and 18 shall be sealed, and bearings in tables 19, 20 and 21 shall be shielded.

NOTE — Sealed bearings are bearings in which the rolling elements and raceways are enclosed by contact seals, i.e., seals fitted to one ring and extending to the other ring with which they make sliding contact.

Shielded bearings are bearings in which the rolling elements and raceways are enclosed by shields fitted to one ring and extending towards the other ring with which they have a small clearance.

The choice of seals or shields is governed by the nature of the particular application since a sealed bearing gives improved protection at the expense of a friction torque increase.

6 Protection against corrosion

For bearings in tables 1 to 6, whether made of conventional rolling bearing steel or corrosion resisting steel, plating or coating shall be subject to agreement between the user and manufacturer.

Bearings in tables 11 to 19, if made of conventional rolling bearing steel, shall have all external surfaces except the inner ring bore surface cadmium plated. If made from corrosion resisting steel, plating shall be subject to agreement between the user and the manufacturer.

Track rollers in tables 20 and 21, if made of conventional rolling bearing steel, shall have the external surface of the outer ring chromium plated, and all other external surfaces except the inner ring bore surface cadmium plated. If made from corrosion resisting steel, plating shall be subject to agreement between the user and the manufacturer.

Where cadmium plating is specified, the thickness of the plating shall not be less than 0,005 mm (0.000 2 in) and not more than 0,012 mm (0.000 5 in).

Where chromium plating is specified, the thickness of the plating shall not be less than 0,012 mm (0.000 5 in) and not more than 0,025 mm (0.001 0 in).

7 Boundary dimensions

The boundary dimensions of the bearings and track rollers are given in tables 1 to 6 (metric series) and tables 11 to 21 (inch series).

NOTES

1 The diameter series noted in tables 1 to 6 are in accordance with ISO 15.

2 The controlling dimensions in tables 11 to 21 and controlling tolerances in table 22 are the inch values.

The contour of the corner shall be either a 45° straight line, as shown in figure 6, or curvilinear, as illustrated in figure 5, for inch series bearings in tables 11 to 21. Metric series bearings in tables 1 to 6 shall have straight line chamfers as shown in figure 6.

8 Tolerances

The tolerances for boundary dimensions (except chamfer dimensions) and running accuracy are given in table 7 for metric series bearings, and in table 22 for inch series bearings. Chamfer dimension limits are given in tables 1 to 6 and 11 to 21.

Where plating is specified, tolerances are applicable after plating.

Radial internal clearance, as defined in ISO 1132, shall be as given in tables 8 to 10 for metric series bearings, and in tables 23 to 28 for inch series bearings.

Values of permissible angular displacement are indicated under tables 5, 6, 16, 17 and 18. Bearing manufacturers shall regard these values as minima, so that, in service, the angles shown may be achieved without causing any damage to the bearing.

NOTE — The bearing users should regard the values of permissible angular displacement as maxima.

9 Basic static radial load ratings

Bearings shall have a basic static radial load rating C_{or} equal to or exceeding the minimum values given in tables 1 to 6 and 11 to 21.

NOTE — Definitions, symbols and methods of evaluating basic static load ratings of bearings made of hardened conventional rolling bearing steel are given in ISO 76. The use of other materials, such as corrosion resisting steels, or of special heat stabilization may affect the load carrying capacity and call for special tests. Such tests should be agreed between the purchaser and the manufacturer.

10 Dimensions and tolerances — Tables

10.1 Index to tables

Table description	Dimensions	Tolerances	Radial internal clearance
	Table No.		
Metric series			
Ball bearings, sealed or shielded			
— single row, rigid, diameter series 0, figure 1	1	7	8
— single row, rigid, diameter series 2, figure 1	2	7	8
— single row, rigid, diameter series 8 and 9, figure 2	3	7	8
— double row, rigid, diameter series 2, figure 1	4	7	8
— double row, self-aligning, diameter series 2, figure 1	5	7	9
Roller bearings, sealed or shielded			
— single row, spherical, diameter series 3, figure 1	6	7	10
Inch series			
Ball bearings			
— single row, rigid, sealed or shielded, figure 1	11	22	23
— single row, rigid, sealed, figure 1	12	22	23
— single row, rigid, torque tube type, extra light, sealed or shielded, figure 1	13	22	24
— single row, rigid, torque tube type, light, sealed or shielded, figure 1	14	22	24
— double row, rigid, angular contact, sealed, figure 1	15	22	23
— double row, self-aligning, sealed or shielded, figure 1	16	22	25
Roller bearings			
— single row, spherical, sealed, figure 1	17	22	26
— double row, spherical, sealed, figure 1	18	22	26
Needle roller bearings			
— single row, shielded, figure 3	19	22	27
— single row, track roller, yoke type, shielded, figure 4	20	22	28
— double row, track roller, yoke type, shielded, figure 4	21	22	28

10.2 Dimension tables — Metric series

Table 1 — Single row rigid ball bearings (figure 1), sealed or shielded, diameter series 0*

Dimensions in millimetres

d	D	B	C	r_s and r_{1s}		C_{Or} , N
				min.	max.	min.
8	22	9	7	0,3	0,8	2 120
10	26	10	8	0,3	0,8	3 050
12	28	10	8	0,3	0,8	3 450
15	32	11	9	0,3	0,8	4 150
17	35	12	10	0,3	0,8	4 800
20	42	14	12	0,3	0,8	7 350
25	47	14	12	0,3	0,8	8 300
30	55	15	13	0,3	0,8	11 200

NOTE — All external surfaces except the inner ring bore surface may be plated (see clause 6).

* See ISO 15.

Dimension tables – Metric series (continued)

Table 2 – Single row rigid ball bearings (figure 1), sealed or shielded, diameter series 2*

Dimensions in millimetres

<i>d</i>	<i>D</i>	<i>B</i>	<i>C</i>	<i>r_s</i> and <i>r_{1s}</i>		<i>C_{Or}</i> , N
				min.	max.	min.
5	16	7	5	0,3	0,8	1 220
6	19	8	6	0,3	0,8	1 660
10	30	11	9	0,3	0,8	3 600
12	32	12	10	0,3	0,8	4 800
15	35	13	11	0,3	0,8	5 700
17	40	14	12	0,3	0,8	7 200
20	47	16	14	0,3	0,8	10 000
25	52	17	15	0,3	0,8	12 500
30	62	18	16	0,3	0,8	16 600

NOTE – All external surfaces except the inner ring bore surface may be plated (see clause 6).

Table 3 – Single row rigid ball bearings (figure 2), sealed or shielded, diameter series 8 and 9*

Dimensions in millimetres

<i>d</i>	<i>D</i>	<i>B</i>	<i>r_s</i> and <i>r_{1s}</i>		<i>C_{Or}</i> , N
			min.	max.	min.
10**	22	6	0,3	0,8	1 900
12**	24	6	0,3	0,8	2 200
15**	28	7	0,3	0,8	2 900
17**	30	7	0,3	0,8	3 150
20	32	7	0,3	0,8	3 100
25	37	7	0,3	0,8	3 800
30	42	7	0,3	0,8	4 400
35	47	7	0,3	0,8	5 100
40	52	7	0,3	0,8	5 700
50	65	7	0,3	0,8	7 650
60	78	10	0,3	0,8	12 500

NOTE – All external surfaces except the inner ring bore surface may be plated (see clause 6).

Table 4 – Double row rigid ball bearings (figure 1), sealed or shielded, diameter series 2*

Dimensions in millimetres

<i>d</i>	<i>D</i>	<i>B</i>	<i>C</i>	<i>r_s</i> and <i>r_{1s}</i>		<i>C_{Or}</i> , N
				min.	max.	min.
6	19	12	10	0,3	0,8	3 250
8	24	14	12	0,3	0,8	4 250
10	30	16	14	0,3	0,8	8 150
12	32	16	14	0,3	0,8	9 000
15	35	16	14	0,3	0,8	10 400
17	40	18	16	0,3	0,8	13 700
20	47	20	18	0,3	0,8	18 600

NOTE – All external surfaces except the inner ring bore surface may be plated (see clause 6).

* See ISO 15.

** These bearings are diameter series 9, remainder are diameter series 8.

Dimension tables – Metric series (concluded)

Table 5 – Double row self-aligning ball bearings (figure 1), sealed or shielded, diameter series 2*

Dimensions in millimetres

<i>d</i>	<i>D</i>	<i>B</i>	<i>C</i>	<i>r_s</i> and <i>r_{1s}</i>		<i>C_{0r}</i> , N
				min.	max.	min.
5	16	12	8	0,3	0,8	475
6	19	14	10	0,3	0,8	710
7	22	14	10	0,3	0,8	915
8	24	15	10	0,3	0,8	1 140
9	26	16	12	0,3	0,8	1 160
10	30	20	14	0,3	0,8	1 760
12	32	20	14	0,3	0,8	2 000
15	35	20	14	0,3	0,8	2 360
17	40	22	16	0,3	0,8	3 050
20	47	24	18	0,3	0,8	4 050

NOTES

- 1 Permissible angular displacement $\theta = 6^\circ$.
- 2 All external surfaces except the inner ring bore surface may be plated (see clause 6).

Table 6 – Single row spherical roller bearings (figure 1), sealed or shielded, diameter series 3*

Dimensions in millimetres

<i>d</i>	<i>D</i>	<i>B</i>	<i>C</i>	<i>r_s</i> and <i>r_{1s}</i>		<i>C_{0r}</i> , N
				min.	max.	min.
8**	30	17	14	0,3	0,8	7 350
10	35	21	17	0,3	0,8	10 800
12	37	21	17	0,3	0,8	12 000
15	42	21	17	0,3	0,8	14 000
17	47	23	19	0,3	0,8	19 000
20	52	26	21	0,3	1,0	22 800
25	62	29	24	0,3	1,0	32 500
30	72	34	27	0,3	1,0	43 000

NOTES

- 1 Permissible angular displacement $\theta = 6^\circ$.
- 2 All external surfaces except the inner ring bore surface may be plated (see clause 6).

* See ISO 15.

** This bearing belongs to diameter series 4*.