**Geotextiles and geotextile-related
products — Determination of water flow
capacity in their plane**

*Géotextiles et produits apparentés — Détermination de la capacité de
débit dans leur plan*

iTeh STANDARD PREVIEW
(standards.iteh.ai)

[ISO 12958:2010](https://standards.iteh.ai/catalog/standards/sist/a66fdaac-c1be-43b7-9d73-baeced0f5a859/iso-12958-2010)

[https://standards.iteh.ai/catalog/standards/sist/a66fdaac-c1be-43b7-9d73-
baeced0f5a859/iso-12958-2010](https://standards.iteh.ai/catalog/standards/sist/a66fdaac-c1be-43b7-9d73-baeced0f5a859/iso-12958-2010)



PDF disclaimer

This PDF file may contain embedded typefaces. In accordance with Adobe's licensing policy, this file may be printed or viewed but shall not be edited unless the typefaces which are embedded are licensed to and installed on the computer performing the editing. In downloading this file, parties accept therein the responsibility of not infringing Adobe's licensing policy. The ISO Central Secretariat accepts no liability in this area.

Adobe is a trademark of Adobe Systems Incorporated.

Details of the software products used to create this PDF file can be found in the General Info relative to the file; the PDF-creation parameters were optimized for printing. Every care has been taken to ensure that the file is suitable for use by ISO member bodies. In the unlikely event that a problem relating to it is found, please inform the Central Secretariat at the address given below.

iTeh STANDARD PREVIEW
(standards.iteh.ai)

ISO 12958:2010

<https://standards.iteh.ai/catalog/standards/sist/a66fdaac-c1be-43b7-9d73-baeced0f5a859/iso-12958-2010>



COPYRIGHT PROTECTED DOCUMENT

© ISO 2010

All rights reserved. Unless otherwise specified, no part of this publication may be reproduced or utilized in any form or by any means, electronic or mechanical, including photocopying and microfilm, without permission in writing from either ISO at the address below or ISO's member body in the country of the requester.

ISO copyright office
Case postale 56 • CH-1211 Geneva 20
Tel. + 41 22 749 01 11
Fax + 41 22 749 09 47
E-mail copyright@iso.org
Web www.iso.org

Published in Switzerland

Contents

Page

Foreword	iv
1 Scope	1
2 Normative references	1
3 Terms and definitions	1
4 Principle.....	2
5 Apparatus and materials.....	2
6 Specimens.....	5
6.1 Handling	5
6.2 Selection.....	5
6.3 Number and dimensions.....	5
6.4 Specimen condition	6
7 Test procedure.....	6
8 Calculations and expression of results	7
9 Test report.....	8
Annex A (informative) Determination of the correction factor R_T for conversion to a water temperature of 20 °C	10
Annex B (informative) Experimental data and calculations for a specimen.....	12
Bibliography.....	13

Foreword

ISO (the International Organization for Standardization) is a worldwide federation of national standards bodies (ISO member bodies). The work of preparing International Standards is normally carried out through ISO technical committees. Each member body interested in a subject for which a technical committee has been established has the right to be represented on that committee. International organizations, governmental and non-governmental, in liaison with ISO, also take part in the work. ISO collaborates closely with the International Electrotechnical Commission (IEC) on all matters of electrotechnical standardization.

International Standards are drafted in accordance with the rules given in the ISO/IEC Directives, Part 2.

The main task of technical committees is to prepare International Standards. Draft International Standards adopted by the technical committees are circulated to the member bodies for voting. Publication as an International Standard requires approval by at least 75 % of the member bodies casting a vote.

Attention is drawn to the possibility that some of the elements of this document may be the subject of patent rights. ISO shall not be held responsible for identifying any or all such patent rights.

ISO 12958 was prepared by Technical Committee ISO/TC 221, *Geosynthetics*.

This second edition cancels and replaces the first edition (ISO 12958:1999), which has been technically revised.

ITIH STANDARD PREVIEW
(standards.iteh.ai)

ISO 12958:2010

<https://standards.iteh.ai/catalog/standards/sist/a66fdaac-c1be-43b7-9d73-baeced0f5a859/iso-12958-2010>

Geotextiles and geotextile-related products — Determination of water flow capacity in their plane

1 Scope

This International Standard specifies a method for determining the constant-head water flow capacity within the plane of a geotextile or geotextile-related product.

NOTE 1 If the full water flow capacity characteristics of the geotextile or geotextile-related product have previously been established, then for control purposes it can be sufficient to determine the water flow capacity at two loads and both gradients.

NOTE 2 The compressibility of the product over time will substantially influence the in-plane water flow capacity. Test methods for assessing the compressive creep behaviour of geotextiles or geotextile-related products are described in ISO 25619-1.

The test report is judged in conjunction with the long-term compressive creep behaviour in order to assess the long-term flow capacity.

iTeh STANDARD PREVIEW

2 Normative references (standards.iteh.ai)

The following referenced documents are indispensable for the application of this document. For dated references, only the edition cited applies. For undated references, the latest edition of the referenced document (including any amendments) applies.

ISO 2854, *Statistical interpretation of data — Techniques of estimation and tests relating to means and variances*

ISO 5813, *Water quality — Determination of dissolved oxygen — Iodometric method*

ISO 9862, *Geosynthetics — Sampling and preparation of test specimens*

ISO 9863-1, *Geosynthetics — Determination of thickness at specified pressures — Part 1: Single layers*

ISO 10320, *Geotextiles and geotextile-related products — Identification on site*

3 Terms and definitions

For the purposes of this document, the following terms and definitions apply.

3.1

normal compressive stress

compressive stress components normal to the plane of the geotextile or geotextile-related product

NOTE The normal compressive stress is expressed in kilopascals.

3.2

in-plane flow

fluid flow within the geotextile or geotextile-related product and parallel to its plane

3.3

in-plane water flow capacity

volumetric flow rate of water per unit width of specimen at a defined gradient and load

NOTE The term transmissivity is related to laminar flow conditions only and equals the water flow capacity at a hydraulic gradient equal to unity. As non-laminar flow may occur, the term water flow capacity is preferred.

3.4

hydraulic gradient

ratio of the head loss in the geotextile or geotextile-related product specimen to the distance between the measuring points

4 Principle

The flow of water within the plane of a geotextile or geotextile-related product is measured under varying normal compressive stresses, with typical hydraulic gradients and with defined contact surfaces.

5 Apparatus and materials

5.1 Constant-head in-plane water flow apparatus, satisfying the following requirements:

- a) The apparatus shall be capable of maintaining a constant head loss at different water levels, at least those corresponding to hydraulic gradients of 0,1 and 1,0, while maintaining a water head at the point of discharge of not greater than 100 mm.
- b) If the water head exceeds 100 mm, the normal stress shall be corrected for the excess.
- c) The apparatus shall be capable of maintaining the proposed normal compressive stress on the specimen without any deformation which would influence the test results.
- d) The apparatus shall include a loading mechanism capable of exerting a constant normal compressive stress on the geotextile specimen to an accuracy of ± 5 %.
- e) The surfaces contacting the specimen shall be closed-cell foam rubber whose properties satisfy the compression-deflection envelope, illustrated in Figure 1, when tested in accordance with ISO 9863-1.

For specimens with a thickness up to 10 mm, foam rubber with a nominal thickness of 10 mm shall be used on each face.

For specimens with a thickness between 10 mm and 25 mm, foam rubber with a nominal thickness of 1 to 1,25 times the specimen thickness shall be used on each face.

For specimens with a thickness over 25 mm, the foam rubber on each face shall have a nominal thickness of 25 mm.

Two layers of foam rubber may be combined to achieve the desired thickness.

The width of the foam shall be the same as that of the loading platen. The length of the foam should normally be the same as the loading platen. However, to avoid obstruction at both the inlet and outlet due to compression of the foam, it is recommended that its length be reduced, where necessary, by 0,4 times its nominal thickness.

When the geotextile-related products to be tested have been designed to perform their hydraulic functions against rigid boundaries, the foam rubber membranes shall not be used, but shall be replaced by the appropriate boundary, e.g. a stiff high-density polyethylene liner or a concrete panel. Products for such applications can be identified typically by the fact that they have no geotextile layers to prevent soil intrusion and in fact are not placed directly against a soil boundary.

When foam rubber layers have not been used, the test report shall include the specific boundary used.

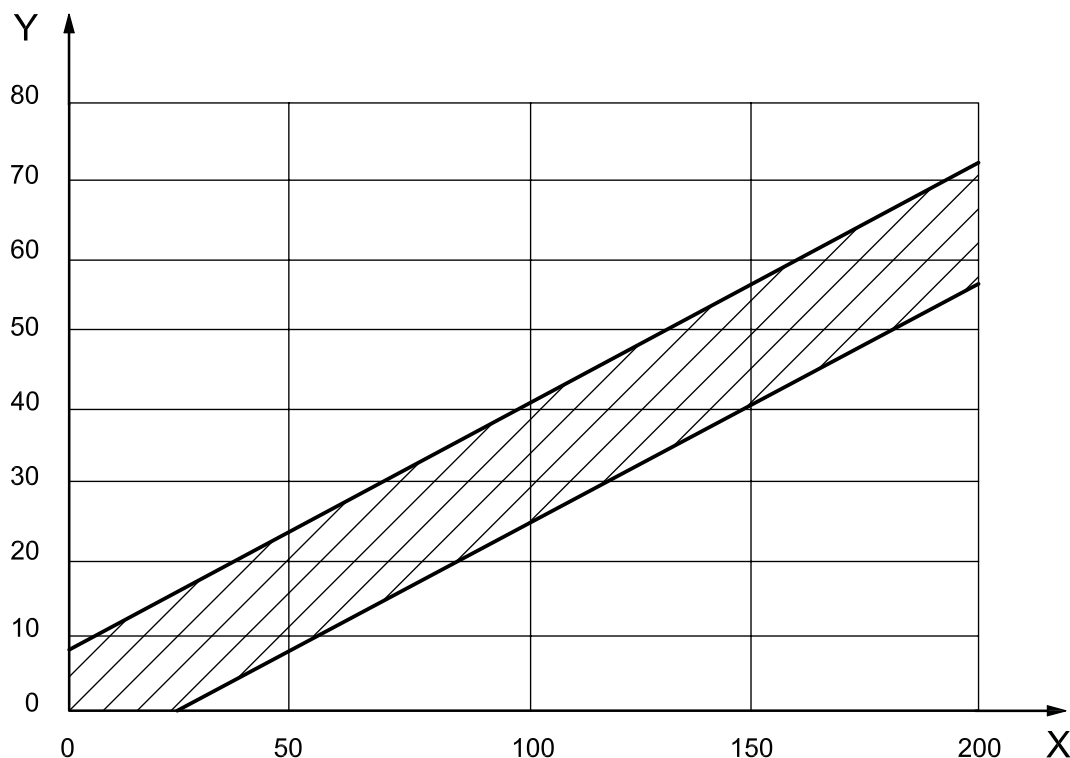
**Key**

X normal compressive stress, in kilopascals

Y thickness reduction, in percent

iTeh STANDARD PREVIEW
(standards.iteh.ai)

Figure 1 — Compression-deflection envelope of an elastomeric closed-cell foam rubber

<https://standards.iteh.ai/catalog/standards/sist/a66fdaac-c1be-43b7-9d73-baed0f5a859/iso-12958-2010>

- f) The apparatus shall have a minimum width of 0,2 m and a minimum net hydraulic length of 0,3 m. It shall be capable of testing specimens up to a thickness of 50 mm. It shall also be capable of accepting foam rubber with a thickness of 25 mm in contact with both faces of the material to be tested.
- g) The apparatus shall be essentially leaktight. At the lowest normal compressive stress and the highest hydraulic gradient, when the platen or pressure membranes with the contact surfaces are seated in the unit without the test specimen, the leakage shall not exceed 0,2 ml/s.

Some examples of apparatus are shown in Figure 2.

For determination of the hydraulic head loss, it is recommended that the apparatus in Figures 2 b) and 2 c) be provided with two manometers at a spacing of at least 0,3 m within the specimen.

For very low flows, the leakage shall not exceed 10 % of the flow value.

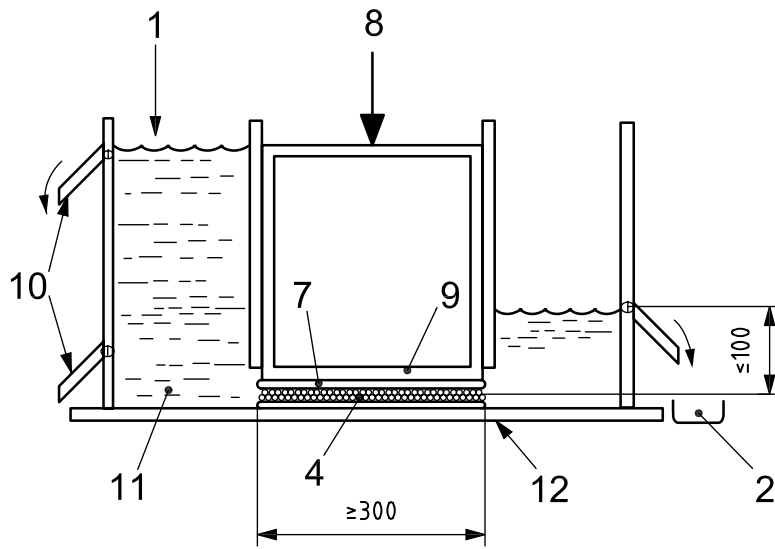

a)

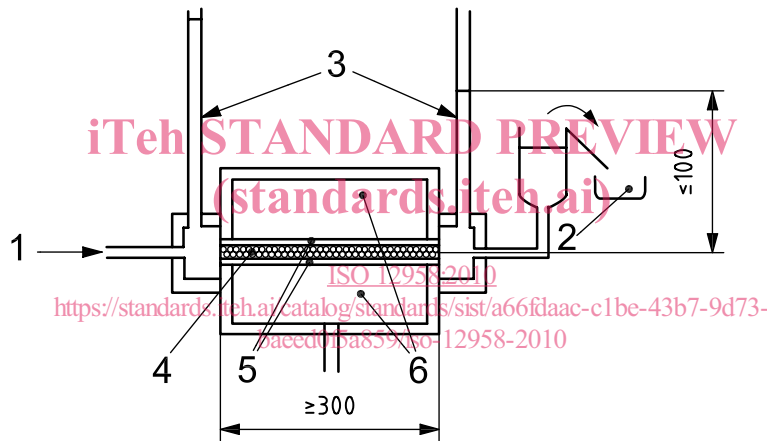

b)

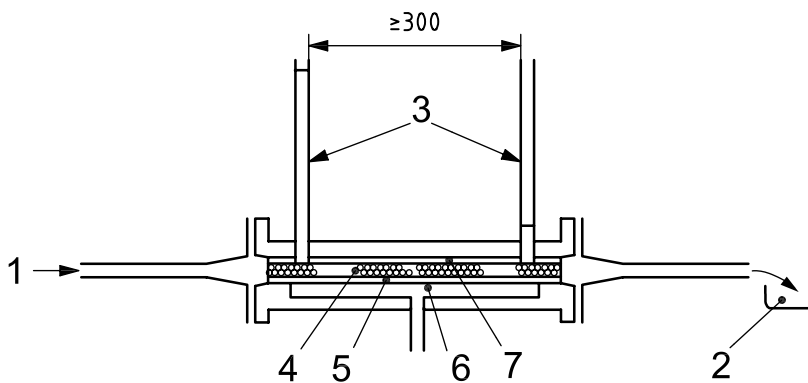

c)

Key

- | | | |
|--------------------|-----------------|------------------------------------------------------|
| 1 water supply | 5 membrane | 9 loading platen |
| 2 water collection | 6 pressure cell | 10 overflow weirs at hydraulic gradients 0,1 and 1,0 |
| 3 manometers | 7 foam | 11 water reservoir |
| 4 specimen | 8 load | 12 base |

Figure 2 — Typical examples of apparatus

5.2 Water: For water flow rates up to 0,3 l/(m·s), the water used shall be de-aerated or fed from a stilling tank. The water shall be at a temperature between 18 °C and 22 °C and the water temperature should preferably be at or above the ambient temperature of the test laboratory. The water shall not be continuously recycled. The oxygen content shall not exceed 10 mg/kg, when measured at the point where the water enters the apparatus.

For water flow rates greater than 0,3 l/(m·s), water from the mains supply may be used. The temperature shall be noted and all necessary measures shall be taken to avoid the inclusion of air in the tap water.

NOTE As temperature correction relates only to laminar flow, it is advisable, should the flow be non-laminar, to work at temperatures as close as possible to 20 °C to minimize inaccuracies associated with inappropriate correction factors.

The water shall be filtered if suspended solids are visible to the naked eye or if solids accumulate on or in the specimen, thus inhibiting flow.

5.3 Dissolved-oxygen meter, or apparatus in accordance with ISO 5813.

5.4 Stopwatch, accurate to 0,1 s.

5.5 Thermometer, accurate to 0,5 °C.

5.6 Equipment for determining the water flow rate: When the water flow rate is determined by measurements of volume, a measuring vessel for determining the volume to an accuracy of 1 % is required. When the water flow rate is measured directly by a gauge, it shall be measurable to an accuracy of 5 %. When the volume is determined by weighing, it shall be determined to an accuracy of 1 %.

5.7 Measuring device for determining the applied head to an accuracy of 1 mm.

5.8 Measuring device for determining the applied normal stress to an accuracy of 1 %.

iTeh STANDARD PREVIEW
(standards.iteh.ai)

[ISO 12958:2010](https://standards.iteh.ai/catalog/standards/sist/a66fdaac-c1be-43b7-9d73-baed0f5a859/iso-12958-2010)

<https://standards.iteh.ai/catalog/standards/sist/a66fdaac-c1be-43b7-9d73-baed0f5a859/iso-12958-2010>

6 Specimens

6.1 Handling

In order to prevent disturbing its structure, the sample shall be handled as infrequently as possible and shall not be folded. Keep the sample in a flat position without any load.

6.2 Selection

Take specimens from the sample in accordance with ISO 9862.

6.3 Number and dimensions

Cut three test specimens from the sample with the length parallel to the machine direction and three specimens with the length parallel to the cross-machine direction so that the specimens measure at least 0,3 m in the length, or flow, direction, and at least 0,2 m in the cross-machine direction. When the width of the product is less than 0,2 m, the full width of the product shall be tested by modifying the apparatus.

For an apparatus with rigid platen loading (see Figure 2 a), the length of the specimen shall be equal to the length of the loading platen, taking into account 5.1 d). For an apparatus with pressure-membrane loading [see Figures 2 b) and 2 c)], the length of the specimen may exceed the loaded length.

For products, without integrated flow to both sides of the core, which are to be used for single-sided drainage, six specimens shall be taken to enable testing of each of the two sides after one of them has been sealed.

It is important that the specimen width is not undersized, i.e. that it shows a good push-tight fit.