



Standard Consumer Safety Specification for Toy Safety¹

This standard is issued under the fixed designation F 963; the number immediately following the designation indicates the year of original adoption or, in the case of revision, the year of last revision. A number in parentheses indicates the year of last reapproval. A superscript epsilon (ϵ) indicates an editorial change since the last revision or reapproval.

^{ε1} NOTE—Paragraphs 4.39.1 and 5.17 were editorially corrected in June 2007.

INTRODUCTION

The purpose of this consumer safety specification is to establish nationally recognized safety requirements for toys. Although this specification will not eliminate the need for the exercise of parental responsibility in selecting toys appropriate to the age of a child, or parental supervision in situations in which children of various ages may have access to the same toys, its application will minimize accidents in the normal, intended use and reasonably foreseeable abuse of the toys covered by this specification. This specification was developed originally as a Voluntary Product Standard under the auspices of the National Bureau of Standards, Department of Commerce, and published in 1976 (PS 72–76). The present revision is intended to update the safety requirements to include the following by reference: published federal mandatory requirements, relevant voluntary standards, certain new requirements for addressing potential hazards, and several technical revisions based on producer experience with the original standard.

1. Scope

1.1 This specification² relates to possible hazards that may not be recognized readily by the public and that may be encountered in the normal use for which a toy is intended or after reasonably foreseeable abuse. It does not purport to cover every conceivable hazard of a particular toy. This specification does not cover product performance or quality, except as related to safety. Except for the labeling requirements pointing out the functional hazards and age range for which the toy is intended, this specification has no requirements for those aspects of a toy that present an inherent and recognized hazard as part of the function of the toy. Such an example is a sharp point necessary for the function of a needle. The needle is an inherent hazard that is well understood by the purchaser of a toy sewing kit, and this hazard is communicated to the user as part of the normal educational process.

1.2 On the other hand, while a riding toy has inherent hazards associated with its use (for example, falling off onto the sidewalk), the possible hazards associated with its construction (sharp edges, exposed mechanisms, etc.) will be minimized by the application of this specification.

1.3 This specification covers requirements and contains test methods for toys intended for use by children under 14 years of age. Different age limits for various requirements will be found in this specification. These limits reflect the nature of the hazards and expected mental or physical ability, or both, of a child to cope with the hazards.

1.4 Articles not covered by this specification are as follows:

- Bicycles
- Tricycles
- Sling shots and sharp-pointed darts
- Playground equipment
- Non-powder guns
- Kites
- Hobby and craft items in which the finished item is not primarily of play value
- Model kits in which the finished item is not primarily of play value

¹ This consumer safety specification is under the jurisdiction of ASTM Committee F15 on Consumer Products and is the direct responsibility of Subcommittee F15.22 on Toy Safety.

Current edition approved March 15, 2007. Published May 2007. Originally approved in 1986. Last previous edition approved in 2003 as F 963 – 03.

² Toy Industry Association, Inc. (TIA) sometimes provides its interpretations of this specification through its counsel as a service to its members and others. The TIA's interpretations are not reviewed or approved by ASTM and should be viewed as TIA's alone.

Crayons, paints, chalks, and other similar art materials in which the material itself or the finished item is not primarily of play value, except that all art materials, whether or not a component of a toy, must comply to LHAMA, in accordance with 4.30.1-4.30.3.

Sporting goods, camping goods, athletic equipment, musical instruments, and furniture; however, toys that are their counterparts are covered. (It is recognized that there is often a fine line between, for example, a musical instrument or a sporting item and its toy counterpart. The intention of the producer or distributor, as well as normal use and reasonably foreseeable abuse, determines whether the item is a toy counterpart.)

Powered models of aircraft, rockets, boats, and land vehicles; however, toys that are their counterparts are covered.

1.5 General guidelines for age labeling toys and toy packaging are contained in Annex A1.

1.6 Information regarding packaging and shipping is contained in Annex A2.

1.7 This consumer safety specification includes the following sections:

Title	Section
Scope	1
Referenced Documents	2
Terminology	3
Safety Requirements	4
Material Quality	4.1
Flammability	4.2
Toxicology	4.3
Electrical/Thermal Energy	4.4
Sound Producing Toys	4.5
Small Objects	4.6
Accessible Edges	4.7
Projections	4.8
Accessible Points	4.9
Wires or Rods	4.10
Nails and Fasteners	4.11
Packaging Film	4.12
Folding Mechanisms and Hinges	4.13
Cords and Elastics in Toys	4.14
Stability and Over-Load Requirements	4.15
Confined Spaces	4.16
Wheels, Tires, and Axles	4.17
Holes, Clearance, and Accessibility of Mechanisms	4.18
Simulated Protective Devices	4.19
Pacifiers	4.20
Projectile Toys	4.21
Teethers and Teething Toys	4.22
Rattles	4.23
Squeeze Toys	4.24
Battery-Operated Toys	4.25
Toys Intended to be Attached to a Crib or Playpen	4.26
Toy Chests	4.27
Stuffed and Beanbag-Type Toys	4.28
Stroller and Carriage Toys	4.29
Art Materials	4.30
Toy Gun Marking	4.31
Balloons	4.32
Certain Toys with Spherical Ends	4.33
Marbles	4.34
Balls	4.35
Pompoms	4.36
Hemispheric-Shaped Objects	4.37
Yo Yo Elastic Tether Toys	4.38
Magnets	4.39
Safety Labeling Requirements	5
Instructional Literature	6
Producer's Markings	7
Test Methods	8
General	8.1
Testing for Hazardous Substance Content	8.2
Method to Dissolve Soluble Matter	8.3

Tests for Cleanliness and Preservative Effectiveness	8.4
Normal Use Testing	8.5
Abuse Testing	8.6
Impact Tests	8.7
Torque Tests for Removal of Components	8.8
Tension Test for Removal of Components	8.9
Compression Test	8.10
Tests for Tire Removal and Snap-in Wheel and Axle Assembly Removal	8.11
Flexure Test	8.12
Test for Mouth-Actuated Toys	8.13
Tests for Toy Chest Lids and Closures	8.14
Projectiles	8.15
Test for Stability of Ride-On Toys	8.16
Stalled Motor Test for Battery-Operated Toys	8.18
Tests for Battery-Powered Ride-On Toys	8.19
Tests for Toys which Produce Noise	8.20
Dynamic Strength Test for Wheeled Ride-On Toys	8.21
Packaging Film Thickness	8.22
Test for Loops and Cords	8.23
Yo Yo Elastic Tether Toy Test Methods	8.24
Magnetic Flux Index	8.25
Identification	9
Age Grading Guidelines	Annex A1
Packaging and Shipping	Annex A2
Design Guidelines for Toys Attached to Cribs or Playpens	Annex A3
Flammability Testing Procedure for Toys	Annex A4
Rationale	Annex A5

1.8 The values stated first are to be regarded as the standard. The values given in parentheses are for information only.

1.9 The following precautionary statement pertains only to the test methods portion, Section 8, of this specification: *This standard does not purport to address all of the safety concerns, if any, associated with its use. It is the responsibility of the user of this standard to establish appropriate safety and health practices and determine the applicability of regulatory limitations prior to use.*

(https://standards.iteh.ai)
Document Preview

2. Referenced Documents

2.1 ASTM Standards:³

- D 374 Test Methods for Thickness of Solid Electrical Insulation
- D 642 Test Method for Determining Compressive Resistance of Shipping Containers, Components, and Unit Loads
- D 880 Test Method for Impact Testing for Shipping Containers and Systems
- D 999 Test Methods for Vibration Testing of Shipping Containers
- D 1193 Specification for Reagent Water
- D 2240 Test Method for Rubber Property Durometer Hardness
- D 3421 Practice for Extraction and Determination of Plasticizer Mixtures from Vinyl Chloride Plastics⁴
- D 4236 Practice for Labeling Art Materials for Chronic Health Hazards
- D 5276 Test Method for Drop Test of Loaded Containers by Free Fall
- F 1313 Specification for Volatile *N*-Nitrosamine Levels in Rubber Nipples on Pacifiers
- F 1148 Consumer Safety Performance Specification for Home Playground Equipment

2.2 ANSI Standards:⁵

- C18.1 American National Standard for Dry Cells and Batteries—Specifications
- S1.4 Specification for Sound Level Meters
- Z315.1 Safety Requirements for Tricycles

2.3 Federal Standards:⁶

- 15 CFR 1150 Marking of Toys, Look-Alike and Imitation Firearms
- 16 CFR 1303 Ban of Lead-Containing Paint and Certain Consumer Products Bearing Lead Containing Paint
- 16 CFR 1500 Hazardous Substances Act Regulations, including the following sections:
 - 1500.3 (c) (6) (vi) Definition of “flammable solid”

³ For referenced ASTM standards, visit the ASTM website, www.astm.org, or contact ASTM Customer Service at service@astm.org. For *Annual Book of ASTM Standards* volume information, refer to the standard’s Document Summary page on the ASTM website.

⁴ Withdrawn.

⁵ Electronic copy available from American National Standards Institute website: www.ansi.org; hard copies from Global Engineering Documents, 15 Inverness Way East, Englewood, CO 80112.

⁶ Available from U.S. Consumer Product Safety Commission website: www.cpsc.gov or U.S. Government Printing Office, Superintendent of Documents; P.O. Box 371954, Pittsburgh, PA 15250-7954; website: www.gpo.gov

- 1500.14(b) (8) Labeling of hazardous art materials
- 1500.18 Banned toys and other banned articles intended for use by children
- 1500.19 Misbranded toys and other articles intended for use by children
- 1500.44 Method for determining extremely flammable and flammable solids
- 1500.47 Method for determining the sound pressure level produced by toy caps
- 1500.48 Technical requirements for determining a sharp point in toys and other articles intended for use by children under 8 years of age
- 1500.49 Technical requirements for determining a sharp metal or glass edge in toys and other articles intended for use by children under 8 years of age
- 1500.50-53 Test method for simulating use and abuse of toys and other articles intended for use by children
- 1500.83 Exemptions for small packages, minor hazards, and special circumstances
- 1500.85 Exemptions from classification as banned hazardous substances
- 1500.86 Exemptions from classification as a banned toy or other banned article for use by children
- 16 CFR 1501 Method for Identifying Toys and Other Articles Intended for Use by Children Under 3 Years of Age which Present Choking, Aspiration, or Ingestion Hazards Because of Small Parts
- 16 CFR 1505 Requirements for Electrically Operated Toys or Other Electrically Operated Articles Intended for Use by Children
- 16 CFR 1510 Requirements for Rattles
- 16 CFR 1511 Requirements for Pacifiers
- 16 CFR 1610 Standard for Flammability of Clothing Textiles
- 21 CFR 110 Current Good Manufacturing Practice in Manufacturing, Processing, Packaging, or Holding Human Food
- 21 CFR 170-189 Food for Human Consumption
- 21 CFR 700-740 Requirements for Specific Cosmetic Products
- 21 CFR 73, 74, 81, 82 Color Additives
- 49 CFR 173.100, 109 Definition of Class C Explosives
- SS-T-312B Tile, Floor: Asphalt, Rubber, Vinyl, VinylAsbestos⁷
- 2.4 *ISO and IEC Standards*.⁸
- ISO 3746:1995 Acoustics—Determination of Sound Power Levels of Noise Sources Using Sound Pressure—Survey Method Using an Enveloping Measurement Surface Over a Reflecting Plane
- ISO 7779 Acoustics—Measurement of Airborne Noise Emitted by Computer and Business Equipment
- ISO 8124-1: 2000 Safety of Toys, Safety Aspects Related to Mechanical and Physical Properties
- ISO 11202 Acoustics—Noise Emitted by Machinery and Equipment—Measurement of Emission Sound Pressure Levels at a Work Station and at Other Specified Positions—Survey Method in situ
- ISO 11204 Acoustics—Noise Emitted by Machinery and Equipment—Measurement of Emission Sound Pressure Levels at a Work Station and at Other Specified Positions—Method Requiring Environmental Corrections
- IEC 60086-2 Primary Batteries: Physical and Electrical Specifications
- IEC 61672-1 Electroacoustics—Sound Level Meters—Part 1: Specifications
- IEC 61672-2 Electroacoustics—Sound Level Meters—Part 2: Pattern Evaluation Tests

3. Terminology

3.1 *Definitions of Terms Specific to This Standard:*

- 3.1.1 *A-weighted sound pressure level (L_{pA})*—the sound pressure level obtained by using standardized A-weighting.
- 3.1.2 *accessible*—(part or component) describing any area of the toy that can be contacted by any portion forward of the collar of the accessibility probe as described in 16 CFR 1500.48 and 16 CFR 1500.49. (See Fig. 1.)

NOTE 1—Dimensions are provided in Fig. 1 for two probes corresponding to two age ranges of children.

- 3.1.3 *alkaline battery*—a non-rechargeable dry cell battery with an alkaline manganese electrochemistry.
- 3.1.4 *aquatic toy*—an article, whether inflatable or not, intended to bear the mass of a child and used as an instrument of play in shallow water. This does not include bath toys, beach balls, and United States Coast Guard-approved life saving devices.
- 3.1.5 *art material*—any substance marketed or represented by the producer or repackager as suitable for use in any phase of the creation of any work of visual or graphic art of any medium. This definition includes items that become a component of the work of art such as paint, canvas, inks, crayons, chalk, solder, brazing rods, flux, paper, clay, stone, thread, cloth, and photographic film. It also includes items that are associated closely with the creation of the final work of art such as brushes, brush cleaners, solvents, ceramic kilns, silk screens, molds, mold making material, and photographic developing chemicals.

⁷ Available from U.S. Government Printing Office Superintendent of Documents, 732 N. Capitol St., NW, Mail Stop: SDE, Washington, DC 20401, <http://www.access.gpo.gov>.

⁸ Available from International Organization for Standardization (ISO), 1 rue de Varembe, Case postale 56, CH-1211, Geneva 20, Switzerland, <http://www.iso.ch>.

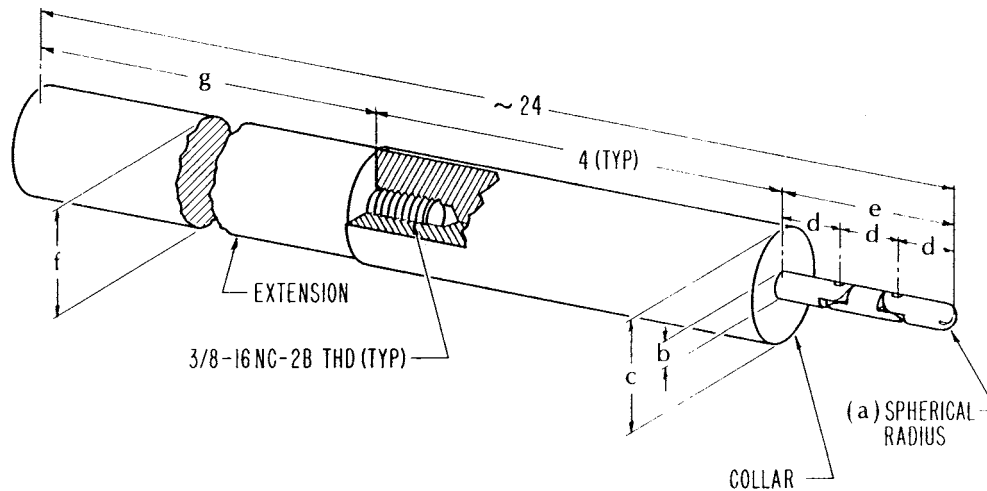

	a	b	c	d	e	f	g
(CHILDREN 0-36 MONTHS INCL)	PROBE A	.110	.220	1.020	.577	1.731	1 18 9/32
(" 37-96 " ")	PROBE B	.170	.340	1.510	.760	2.280	1 1/2 17 25/32

ALL DIMENSIONS IN INCHES
FIG. 1 Accessibility Probes

3.1.6 *ball*—any spherical, ovoid, or ellipsoidal object that is designed or intended to be thrown, hit, kicked, rolled, dropped, or bounced. The term “ball” includes any spherical, ovoid, or ellipsoidal object that is attached to a toy or article by means of string, elastic cord, or similar tether. The term “ball” also includes any multisided object formed by connecting planes into a generally spherical ovoid, or ellipsoidal shape that is designated or intended to be used as a ball. The term “ball” does not include dice, or balls permanently enclosed inside pinball machines, mazes, or similar outer containers. A ball is permanently enclosed if, when tested in accordance with 16 CFR 1500.53, it is not removed from the outer container.

3.1.7 *battery-operated toy*—toy having at least one function dependent on electricity and powered by batteries.

3.1.8 *burr*—a roughness that may be found at an edge or joint of a toy or component if the material is not severed or finished cleanly.

3.1.9 *button cell battery*—a battery having a diameter greater than its height.

3.1.10 *C-weighted peak sound pressure level (L_{Cpeak})*—the peak sound pressure level obtained when using standardized C-weighting.

3.1.11 *close-to-the-ear toy*—a toy that is intended to be used close to the ear, that is, the sound emitting part of such a toy is normally put against the ear of a child (example—toy telephones that emit sounds from the earpiece).

3.1.12 *collapse*—sudden or unexpected folding of a structure.

3.1.13 *compression spring*—spring which essentially returns to its initial state after compression.

3.1.14 *continuous sound*—any steady-state sound or group of variable sounds greater than one second in duration.

3.1.15 *cord*—a length of slender, flexible material including monofilaments, woven and twisted cord, rope, plastic textile tapes, ribbon, and those fibrous materials commonly called string.

3.1.16 *cosmetics*—any article intended or likely to be rubbed, sprinkled, or sprayed on, introduced onto, or otherwise applied to the human body for cleansing, beautifying, promoting or enhancing attractiveness, or for altering appearance.

3.1.17 *crushing*—injury to part of the body resulting from compression between two rigid surfaces.

3.1.18 *curled edge*—an edge in which the portion of the sheet adjacent to the edge is bent into an arc and forms an angle of less than 90° with the base sheet, as shown in Fig. 2.

3.1.19 *discharge mechanism*—an inanimate system for releasing and propelling a projectile.

3.1.20 *driving mechanism*—assembly of linked parts or components (for example, gears, belts, winding mechanisms), at least one of which moves, powered by a source (for example, electrical or mechanical means) independent of the child.

3.1.21 *edge, hazardous*—an accessible edge that presents an unreasonable risk of injury during the normal use and reasonably foreseeable abuse of a toy. Metal and glass edges on toys intended for children under the age of eight years are defined as

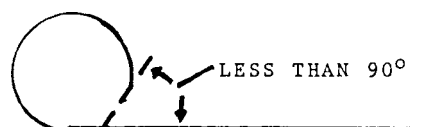

FIG. 2 Curled Edge

potentially hazardous if they fail the sharp edge test described in 16 CFR 1500.49. Edges other than metal and glass are defined as potentially hazardous if they are sharp to the touch under casual handling conditions.

3.1.22 *elastic*—material that will recover its former size and shape essentially and instantaneously after being elongated at least 10 % at a testing speed of not less than 20 in. (510 mm)/min.

3.1.23 *equivalent sound pressure level (L_{Aeq})*—the level of a steady-state sound which, in a stated time period and at a stated location, has the same A-weighted sound energy as the time-varying sound.

3.1.24 *explosive action*—the sudden release of energy characterized by the rapid expansion or bursting of a material.

3.1.25 *extension spring*—spring which essentially returns to its initial state after tension.

3.1.26 *fastener*—mechanical device which attaches two or more elements together (for example, screws, rivets, and staples).

3.1.27 *feathering*—the beveling of an edge (or decrease in thickness moving toward the edge) caused during the shearing or cutting of material.

3.1.28 *flash*—excess material that escapes between the mating parts of a mold assembly.

3.1.29 *folding mechanism*—an assembly of hinged, pivoted, folding, or sliding members that can produce a crushing, scissoring, pinching, or shearing action during operation.

3.1.30 *fuzz*—bits of fibrous-type material that can be readily removed from toys with a pile surface.

3.1.31 *hand-held toy*—a toy that is intended to be used or operated while being held in the hand. Examples include toy tools, small electronic games, stuffed animals, dolls, musical toys, and cap-firing toys.

3.1.32 *hazard*—any characteristic of a toy that presents an unreasonable risk of injury or illness during normal use or as a result of reasonably foreseeable abuse.

iTeh Standards (<https://standards.iteh.ai>) Document Preview

[ASTM F963-07e1](https://standards.iteh.ai/catalog/standards/sist/2b160cb3-65ff-483b-9658-c1112632c2d6/astm-f963-07e1)

<https://standards.iteh.ai/catalog/standards/sist/2b160cb3-65ff-483b-9658-c1112632c2d6/astm-f963-07e1>

3.1.33 *hazardous magnet*—a magnet which has a flux index >50 (refer to test method 8.25) and which is in any of the following shapes and sizes (refer also to Fig. 3):

- (1) A cylinder with a length of not more than 32 mm and a diameter of not more than 11 mm,
- (2) A disk with a diameter of not more than 26 mm and a thickness of not more than 5 mm,
- (3) A sphere with a diameter of not more than 22 mm, or
- (4) Any solid that will fit entirely within the volume or envelope of any of the above defined shapes.

3.1.34 *hazardous magnet component*—any part of a toy which contains an attached or imbedded magnet that meets the dimensional criteria set forth in 3.1.33 and which has a flux index >50 as determined in accordance with the method in 8.25.

3.1.35 *helical spring*—spring in the form of a coil.

3.1.36 *hemmed edge*—an edge in which the portion of the sheet adjacent to the edge is folded back on the sheet itself through an angle of approximately 180°, so that the portion of the sheet adjacent to the edge is approximately parallel to the main sheet, as shown in Fig. 4.

3.1.37 *hinge-line clearance*—the distance between the stationary portion of a toy and the movable portion along, or adjacent to, a line projected through the axis of rotation, shown as Dimension A in Fig. 5.

3.1.38 *impulsive sound*—any sound that is characterized by a brief excursion of sound pressure significantly exceeding the

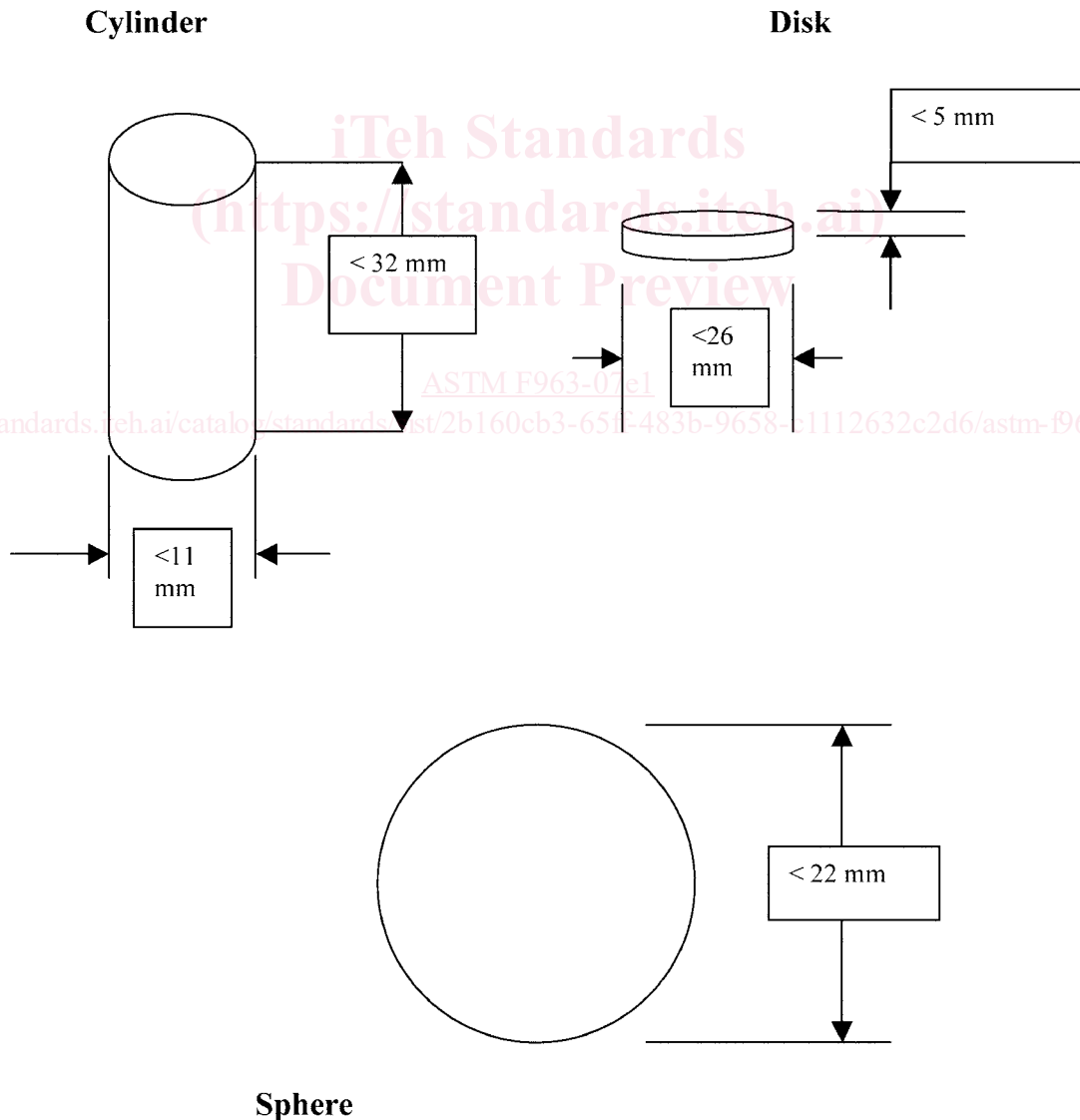
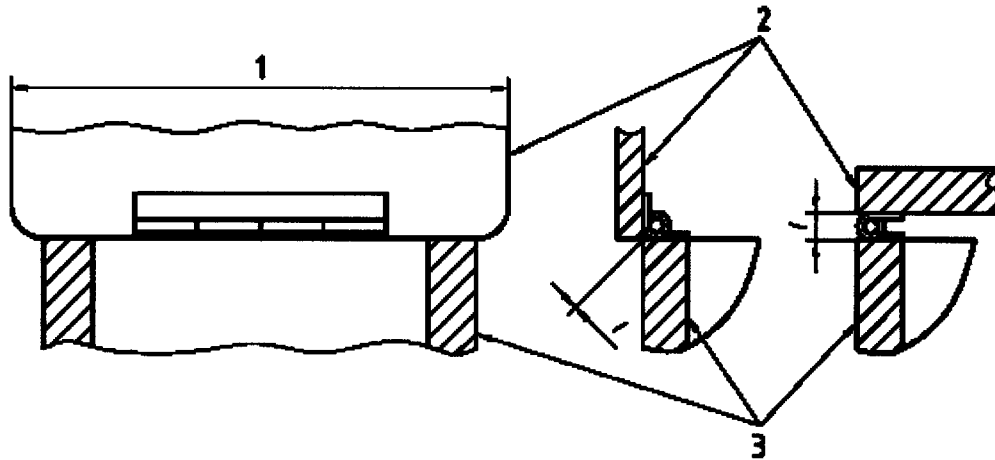

FIG. 3 Hazardous Magnet Shapes and Sizes



FIG. 4 Hemmed Edge



Key

- 1 Hinge line
- 2 Lid
- 3 Box

l = Hinge-line clearance

FIG. 5 Changing Clearance at Hinge Line

ambient noise, typically less than one second in duration.

3.1.39 *lap joint*—a joint in which an edge overlaps a parallel surface but is not necessarily attached to it mechanically at all points along the length, as in the examples shown in Fig. 6.

3.1.40 *large and bulky toy*—toy that has a projected base area of more than 400 in.² (0.26 m²) or a volume of more than 3 ft³ (0.08 m³) calculated without regard to minor appendages.

NOTE 2—The base area for toys having permanently attached legs is measured by calculating the area enclosed by straight lines connecting the outermost edge of each leg of the perimeter.

3.1.41 *latex balloon*—any toy or decorative item consisting of a latex bag that is designed to be inflated by air or gas. The term does not include inflatable children’s toys that are used in aquatic activities such as rafts, water wings, swim rings, or other similar items.

3.1.42 *marble*—a sphere made of a hard material, such as glass, agate, marble, or plastic, that is used in various children’s games, generally as a playing piece or marker. The term “marble” does not include a marble permanently enclosed in a toy or game. A marble is permanently enclosed if, when tested in accordance with 16 CFR 1500.53, it is not removed from the toy or game.

3.1.43 *maximum A-weighted sound pressure level (L_{AFmax})*—the maximum sound pressure level obtained when using standardized A-weighting and fast detector response (time-weighting).

3.1.44 *non-replaceable battery*—an electrochemical device that will not require user accessibility or user replacement for the expected life of the product or devices it is intended to power. Such batteries will not be accessible when tested in accordance with the normal use and, where appropriate, reasonably foreseeable abuse tests of 8.6 through 8.10.

3.1.45 *normal use*—play modes that conform to the instructions accompanying the toy, that have been established by tradition or custom, or that are evident from an examination of the toy.

3.1.46 *packaging*—material accompanying the toy when purchased, but having no intended play function.

3.1.47 *peak sound pressure level (L_{Cpk})*—the greatest C-weighted instantaneous sound pressure level within the period of observation.

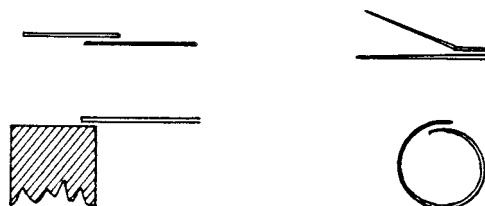

FIG. 6 Typical Lap Joints

3.1.48 *pinching*—created when two moving or one moving and one fixed surface come together in such a way that they could entrap and compress flesh, usually resulting in a contusion or laceration.

3.1.49 *point, hazardous*—an accessible point that presents an unreasonable risk of injury during normal use or reasonably foreseeable abuse. Points on toys intended for children under the age of 8 years are potentially hazardous if they fail the sharp point test described in 16 CFR 1500.48.

3.1.50 *pompom*—lengths or strands of fiber, yarns, or threads clamped or secured and tied in the center, and brushed up to form a spherical shape. Also included are spherical-shaped attachments made of stuffed material.

3.1.51 *principal display panel*—the display panel for a retail package or container, bin, or vending machine that is most likely to be displayed, shown, presented, or examined under normal or customary conditions of display for retail sale.

3.1.52 *projectile*—an object propelled by means of a discharge mechanism capable of storing and releasing energy under the control of the operator.

3.1.53 *projection, hazardous*—a projection that, because of its material or configuration, or both, may present a puncture hazard if a child should fall onto it. Excluded from this definition are puncture hazards to the eyes or mouth, or both, because of the impossibility of eliminating puncture hazards to those areas of the body by product design.

3.1.54 *protective cap or cover*—a component that is attached to a potentially hazardous edge or projection to reduce the possibility of injury.

3.1.55 *protective tip*—a component that is attached to the impacting end of a projectile to minimize injury if it should impact on the body, and also to prevent damage to the projectile upon striking a target, provide a means of attaching the projectile to the target as in the case of suction cups, or prevent damage to inanimate objects.

3.1.56 *rattle*—a toy that is clearly designed to emit sound when shaken typically intended for children under 18 months.

3.1.57 *reasonably foreseeable abuse*—conditions to which a child may subject a toy that are not normal use conditions, such as deliberate disassembly, dropping, or using the toy for a purpose for which it was not intended. Simulated use and abuse tests for toys are given in 16 CFR 1500.50, 1500.51, 1500.52, and 1500.53 (excluding the bite test, Paragraph (c), of each section).

3.1.58 *reference box*—a hypothetical surface which is the smallest rectangular parallelepiped that encloses the toy without regard to minor appendages.

3.1.59 *rigid*—any material having a hardness exceeding 70 Shore A scale durometer, as measured by the latest revision of Test Method D 2240.

3.1.60 *rolled edge*—an edge in which the portion of the sheet adjacent to the edge is bent into an arc and forms an angle between 90 and 120° with the main sheet, as shown in Fig. 7.

3.1.61 *simulated protective equipment*—toys designed to mimic products that infer some sort of physical protection to the wearer (for example, protective helmets and visors).

3.1.62 *squeeze toy*—a handheld pliable toy, intended for children under the age of 18 months, usually incorporating a noise-making feature activated by forcing air through an opening when flexed or squeezed, and which recovers to its original shape when released.

3.1.63 *soft-filled toy/stuffed toy*—toy, clothed or unclothed, with soft body surfaces and filled with soft materials, allowing compression of the torso readily with the hand.

3.1.64 *splinter*—sharp pointed fragment.

3.1.65 *spiral spring*—clockwork-type spring.

3.1.66 *steady-state sound (noise)*—noise in which there are negligibly small fluctuations of sound pressure level within the period of observation.

3.1.67 *strap*—a piece of flexible material in which the width is significantly greater than the thickness.

3.1.68 *tabletop, floor, and crib toy*—toys intended to be played with while attached to or resting on a table top, floor, or crib. Examples of such toys include, but are not limited to, toy vehicles, stacking toys, large and bulky toys, games, and activity toys that attach to crib rails.

3.1.69 *tangle or form a loop*—loops that are formed by reasonably foreseeable manipulation of the cord/strap/elastic. Loops that are formed by excessive or intricate manipulations, or both, of the cord/strap/elastic shall be considered as exempt.

3.1.70 *teether*—toy designed for oral use and intended primarily for symptomatic relief of teething discomfort.

3.1.71 *tool*—screwdriver, coin, or other object which may be used to operate a screw, clip, or similar fixing device.

3.1.72 *toy*—any object designed, manufactured, or marketed as a plaything for children under 14 years of age.

3.1.73 *yo yo elastic tether toy*—a toy consisting of an elastic tether that usually contains a loop on one end to wear around the finger, and a flexible object on the other end intended to be thrown and returned to the hand.

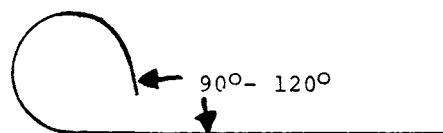

FIG. 7 Rolled Edge

4. Safety Requirements

4.1 *Material Quality*—Toys may be made from new or reprocessed materials and shall be visually clean and free from infestation. The materials shall be assessed visually by the unaided eye rather than under magnification. If reprocessed materials are used, they must be refined so that the level of hazardous substances conforms to the requirements of 4.3.1.

4.2 *Flammability*—Materials other than textiles (excluding paper) used in toys shall not be flammable, as defined under 16 CFR 1500.3 (c) (6) (vi) under the Federal Hazardous Substances Act (FHSA). For testing purposes, any textile fabrics used in toys should comply with 16 CFR 1610. A test procedure for testing flammability of toys, which is an interpretation of 16 CFR 1500.44, is contained in Annex A4.

4.3 Toxicology:

4.3.1 *Hazardous Substances*—Toys or materials used in toys shall conform to the FHSA and to the regulations promulgated under that act. Exemptions to this act for certain types of toys are given in 16 CFR 1500.85. The regulations define limits for substances that are toxic, corrosive, an irritant, sensitizer or pressure generating, and radioactive, flammable, and combustible materials. Testing references for hazardous substance content are given in 8.2. It should be noted that specific states may have hazardous substances regulations that are more restrictive than the Federal regulations.

4.3.2 *Manufacturing and Packaging of Food*—All food products supplied with toys shall be manufactured and packaged in compliance with 21 CFR 110, which is concerned with the sanitation practices for the manufacture, processing, packaging, or holding of human food.

4.3.3 *Indirect Food Additives*—Toy components intended to be used in contact with food, such as toy cooking utensils, shall conform to the applicable requirements of the Food, Drug and Cosmetic Act (FDCA), specifically 21 CFR 170 through 189.

4.3.3.1 *Toys in Contact with Food*—Toys comprising components intended to be used in contact with food, such as toy cooking utensils and toy tableware shall meet the requirements of 6.7 for instructional literature.

4.3.3.2 *Ceramicware, Lead, and Cadmium Contamination*—Ceramic toy components intended or likely to hold food, such as a porcelain tea set, shall conform to the applicable requirements of the FDCA, Section 402 (a) (2) (c), and FDA Compliance Policy Guides.

4.3.4 *Cosmetics*—Cosmetics shall conform to the requirements of the Federal FDCA as codified in 21 CFR. The regulations applicable to cosmetics are stated in 21 CFR 700 through 740. The color additive regulations applicable to cosmetics are found in 21 CFR 73, 74, 81, and 82.

4.3.4.1 In addition, cosmetics intended for use by children under 8 years of age shall meet all requirements of this specification and the FHSA regulations, notwithstanding the exclusions of 16 CFR 1500.81 and 1500.3 (b) (4) (ii).

4.3.4.2 The requirements from the Food and Drug Administration (FDA) will therefore be additive to those existing for children’s products.

4.3.5 *Paint and Similar Surface-Coating Materials*—Paint and other similar surface-coating materials applied to toys shall comply with the lead content provisions of 16 CFR 1303, issued under the Consumer Product Safety Act (CPSA).

4.3.5.1 The regulation prohibits the use of paints or similar surface-coating materials that contain lead or lead compounds and in which the lead content (calculated as lead metal [Pb]) is in excess of 0.06 % (600 ppm) of the weight of the *total* nonvolatile content of the paint or the weight of the dried paint film.

4.3.5.2 In addition, surface-coating materials shall not contain compounds of antimony, arsenic, barium, cadmium, chromium, lead, mercury, or selenium, of which the metal content of the *soluble* material is in excess of the levels by weight of the contained solids (including pigments, film solids, and driers) given in Table 1. The analytical results obtained should be adjusted in accordance with the test method in 8.3.4.3 prior to comparing them to the values in Table 1 to determine conformance. The soluble level shall be determined by dissolving the contained solids (dried film including pigments, film solids, and driers) as specified in 8.3.

4.3.6 *Cosmetics, Liquids, Pastes, Putties, Gels, and Powders*—The purpose of this requirement is to minimize the risk associated with the lack of cleanliness, shelf life, and contamination of cosmetics, liquids, pastes, putties, gels, and powders used in toys (excluding art materials). It sets standards for cleanliness and the ability to withstand extended shelf life or contamination, or both, during use without microbiological degradation.

4.3.6.1 Water used in the manufacturing and filling of toys shall be prepared according to the bacteriological standards for USP Purified Water. (**Warning**—The various methods for producing purified water each present different potentials for contaminating the final product. Purified water produced by distillation is sterile, provided that the production equipment is suitable and sterile. On the other hand, ion-exchange columns and reverse osmosis units require special attention in that they afford sites for microorganisms to foul the system and contaminate the effluent. Frequent monitoring may thus be called for, particularly with the use of these units following periods of shutdown of more than a few hours.)

**TABLE 1 Maximum Soluble Migrated Element in ppm (mg/kg)
Toy Material**

Antimony (Sb)	Arsenic (As)	Barium (Ba)	Cadmium (Cd)	Chromium (Cr)	Lead (Pb)	Mercury (Hg)	Selenium (Se)
60	25	1000	75	60	90	60	500

4.3.6.2 The formulations of these products used in toys shall be such that they are not subject to microbial degradation during shelf life or reasonably foreseeable use.

4.3.6.3 The cleanliness of these products used in toys and their ingredients shall be determined in accordance with 8.4.1. Formulations used to prevent microbial degradation shall be evaluated in accordance with 8.4.2.

4.3.6.4 Formulations of cosmetics shall be evaluated for potential microbiological degradation in accordance with 8.4.2.

4.3.7 *Stuffing Materials*—Loose fillers for stuffed toys shall be free of objectionable matter originating from insect, bird, rodent, or other animal infestation and of contaminants, such as splinters and metal chips to the extent possible in good manufacturing practice. The test methods that shall be used to determine objectionable material are in Chapter 16 of *Official Methods of Analysis of the Association of Official Analytical Chemists*.⁹ In addition, fiber filling, whether natural or synthetic, should meet the requirements of Title 34, Chapter 47, Section 47.317, “Tolerances of the Commonwealth of Pennsylvania Regulation for Stuffed Toys.”

4.3.8 *DEHP (DOP)*—Pacifiers, rattles, and teething toys shall not intentionally contain DI (2-ethylhexyl) phthalate (also known as dioctyl phthalate). To prevent trace amounts of DEHP (DOP) from affecting analysis, up to 3 % of total solid content will be accepted in the result, when tested in accordance with Practice D 3421.

4.4 *Electrical/Thermal Energy*—Toys operating from nominal 120-V branch circuits shall conform to 16 CFR 1505, issued under the FHSA.

4.5 *Sound-Producing Toys*—These requirements are intended to minimize the possibility of hearing damage that might be caused by toys that are designed to produce sound. These requirements are applicable before and after testing in accordance with 8.5 through 8.10. These requirements do not apply to: (1) sounds produced by mouth-actuated toys where the sound pressure level is determined by the blowing action of the child; (2) child-actuated sounds such as those produced by xylophones, bells, drums, and squeeze toys where the sound pressure level is determined by the muscular action of the child. The continuous sound pressure requirements do not apply to rattles; however, rattles are covered by impulsive sound pressure requirements; (3) radios, tape players, CD players, and other similar electronic toys and toys where the sound output is dependent on the content of removable media (for example, game cartridge, flash cards, and so forth); (4) toys that are connected to or interfaced with external devices (for example, televisions, computers) where the sound pressure level is determined by the external device; and (5) sound emitted from earphones/headphones.

4.5.1 *Requirements*—When tested in accordance with 8.20, toys that are designed to emit sound shall conform to the following requirements:

4.5.1.1 The A-weighted equivalent sound pressure level, L_{Aeq} , of continuous sounds produced by close to the ear toys shall not exceed 65 dB.

4.5.1.2 The A-weighted equivalent sound pressure level, L_{Aeq} (maximum A-weighted sound pressure level, L_{Amax} , for pass-by tests), of continuous sounds produced by all other toys except close-to-the-ear toys shall not exceed 85 dB.

4.5.1.3 The C-weighted peak sound pressure level, L_{Cpeak} , of impulsive sounds produced by close to the ear toys shall not exceed 95 dB.

4.5.1.4 The C-weighted peak sound pressure level, L_{Cpeak} , of impulsive sounds produced by any type of toy excluding toys using explosive action (for example, percussion caps) shall not exceed 115 dB.

4.5.1.5 The C-weighted peak sound pressure level, L_{Cpeak} , of impulsive sounds produced by a toy using percussion caps or other explosive action shall not exceed 125 dB.

4.6 *Small Objects*—These requirements are intended to minimize the hazards from choking, ingestion, or inhalation to children under 36 months of age created by small objects.

4.6.1 Toys that are intended for children under 36 months of age are subject to the requirements of 16 CFR 1501. Criteria for determining which toys are subject to these requirements are provided, in part, in 16 CFR 1500.50 and 1501 and also in Annex A1 of this specification. The requirements of 16 CFR 1501 state, in part, that no toy (including removable, liberated components, or fragments of toys) shall be small enough without being compressed to fit entirely within a cylinder of the specified dimensions as shown in Fig. 8. For the purposes of this specification, fragments of toys include, but are not limited to, pieces of flash, slivers of plastics, pieces of foam, or fine bits or shavings. Pieces of paper, fabric, yarn, fuzz, elastic, and string are excluded from this requirement.

4.6.1.1 The requirements are applicable before and after use and abuse testing in accordance with Section 8 to determine the accessibility of small objects such as small toys or components of toys including eyes, squeakers, or knobs, or pieces that break off or are removed from toys.

4.6.1.2 The following articles are exempt from the requirements: balloons; books and other paper articles; writing materials (crayons, chalk, pencils, and pens); phonograph records and compact discs (CDs); modeling clay and similar products; and fingerpaints, watercolors, and other paint sets. A listing of exempt articles is provided in 16 CFR 1501.3.

4.6.1.3 Toys that are intended to be assembled by an adult and contain potentially hazardous small objects in the unassembled state shall be labeled in accordance with 5.8.

4.6.2 *Mouth-Actuated Toys*—This requirement relates to toys, such as noisemakers, that are intended to be actuated repeatedly

⁹ “Extraneous Materials: Isolation,” *Official Methods of Analysis of the Association of Official Analytical Chemists*, 15 ed., Chapter 16, 1990.

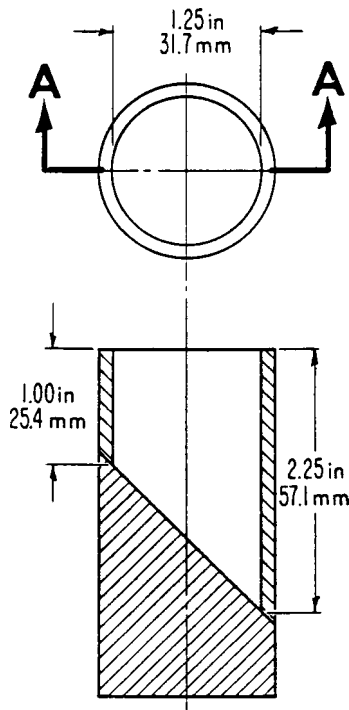

FIG. 8 Small Parts Cylinder

by blowing or sucking. Mouth-actuated toys that contain loose objects, such as spheres in a whistle, or inserts, such as reeds in a noisemaker, shall not release an object that will fit within the small parts test cylinder, as shown in Fig. 8, when air is alternately blown and sucked rapidly through the mouthpiece, according to the procedure described in 8.13. The procedure of 8.13 shall also be applied to the outlet if the air outlet is capable of being inserted into or covered by the mouth.

4.6.2.1 Small objects contained in an inflatable toy shall not be liberated during inflation or deflation.

4.6.3 Toys and games that are intended for use by children who are at least three years old (36 months) but less than six years of age (72 months) are subject to the requirements of 16 CFR 1500.19. With the exception of products such as paper punch-out games and similar items, any toy or game that is intended for use by children who are at least three years old (36 months) but less than six years of age (72 months) and includes a small part is subject to the labeling requirements in accordance with 5.11.2.

4.7 *Accessible Edges*—Toys shall not have accessible, potentially hazardous sharp edges. Toys that are intended to be assembled by an adult, and may contain unprotected potentially hazardous sharp edges in the unassembled state, shall be labeled in accordance with 5.8.

4.7.1 Potentially hazardous sharp metal and glass edges are defined in 16 CFR 1500.49. Toys intended for use by children under 8 years of age are subject to this requirement before or after use and abuse testing, or both, as specified in 8.5-8.10. An illustration of a sharp edge tester is shown in Fig. 9.

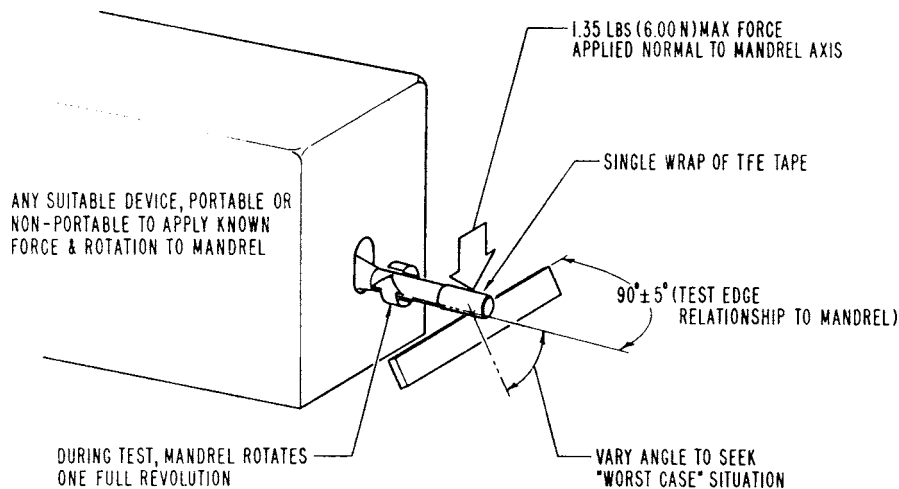

FIG. 9 Principle of Sharp Edge Test

4.7.2 Toys containing potentially hazardous edges that are a necessary part of the function of a toy shall carry cautionary labeling as specified in 5.10 if the toy is intended for use by children from 48 to 96 months. Toys intended for children aged less than 48 months shall not have accessible hazardous functional sharp edges.

4.7.3 *Metal Toys*—Accessible metal edges, including holes and slots, shall be free of hazardous burrs and feathering, or shall be hemmed, rolled, or curled, or shall be covered with a permanently affixed device or finish.

NOTE 3—Regardless of the manner in which edges are finished, they are subject to the sharp edge technical requirements as described in 4.7.1. If a device is used to protect an edge, it shall not become detached after being tested in accordance with the appropriate procedures described in 8.5-8.10.

4.7.4 *Molded Toys*—Accessible edges, corners, or mold parting areas of molded toys should be free of hazardous edges produced by burrs and flash or so protected that hazardous edges are not exposed.

4.7.5 *Exposed Bolts or Threaded Rods*— If the ends of bolts or threaded rods are accessible, the thread shall be free of exposed, hazardous sharp edges and burrs, or the ends shall be covered by smooth finish caps so that hazardous sharp edges and burrs will not be exposed. Any caps that are used shall be subjected to the compression test noted in 8.10, regardless of whether the cap is accessible to flat-surface contact during the appropriate impact test(s) described in 8.7. Protective caps shall also be subjected to the tension test in 8.9 and the torque test in 8.8.

4.8 *Projections*—This requirement relates to potentially hazardous projections in toys intended for use by children under 8 years of age. This requirement is intended to minimize possible puncture hazards to the skin that might be caused should a child fall on a rigid projection, such as unprotected ends of axles, actuating levers, and decorative features. Due to the extremely sensitive nature of the eyes and interior of the mouth, this requirement will not, nor is it intended to, provide protection to those areas of the body. If a projection appears to present a potential skin puncture hazard, the projection shall be protected by suitable means, such as by turning back the end of a wire or by affixing a smoothly finished protective cap or cover, which effectively increases the surface area for potential contact with the skin. The toy shall meet this requirement both before and after testing in accordance with 8.5-8.10. Toys intended to be repeatedly assembled and taken apart shall have the individual pieces and fully assembled articles, as shown on packaging graphics, instructions or other advertising, evaluated separately. The requirements for the assembled toy do not apply to toys where the assembling makes up a significant part of the play value of the toy. Since this requirement relates to hazards arising from a child falling onto a toy, only vertical or nearly vertical projections are required to be evaluated. The toy shall be tested in its most onerous position. Corners of structures do not fall under this category.

4.9 *Accessible Points*—Toys shall not have accessible, potentially hazardous sharp points that may occur because of the following: configuration of the toy; assembly devices such as wires, pins, nails, and staples that are fastened poorly; poorly sheared sheet metal; burrs on screws; and splintered wood. Toys that are intended to be assembled by an adult and may contain potentially hazardous sharp points in the unassembled state shall be labeled in accordance with 5.8.

4.9.1 Potentially hazardous sharp points are defined by 16 CFR 1500.48. Toys intended for use by children under 8 years of age are subject to this requirement before or after use and abuse testing, or both, as specified in 8.5-8.10. An illustration of a sharp-point tester is shown in Fig. 10.

ASTM F963-07e1

<https://standards.iteh.ai/catalog/standards/sist/2b160cb3-65ff-483b-9658-c1112632c2d6/astm-f963-07e1>

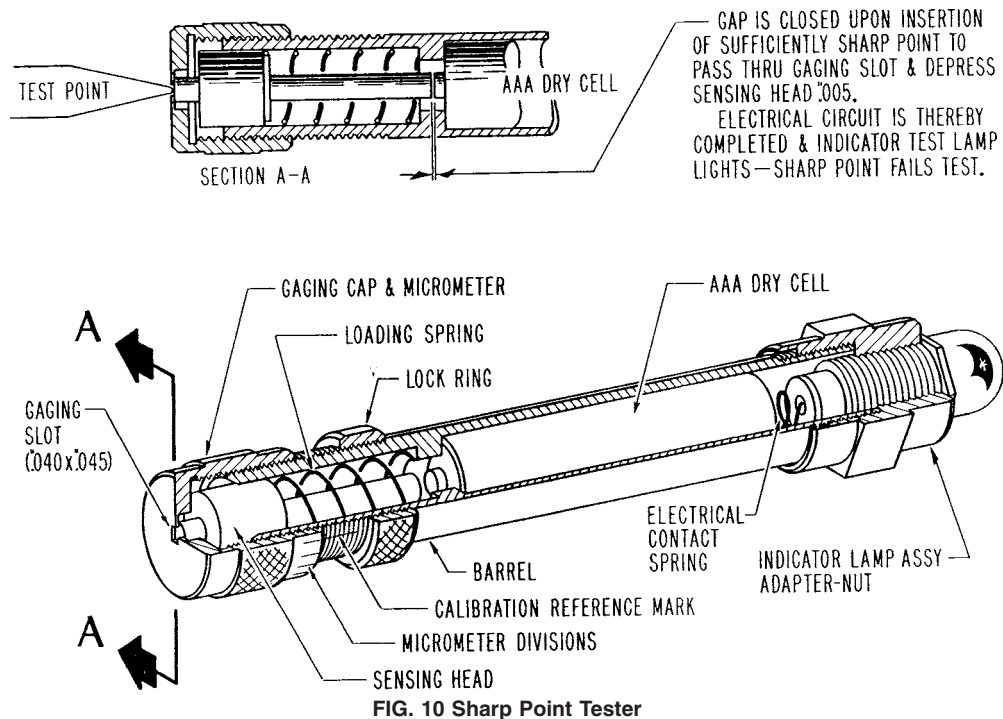

FIG. 10 Sharp Point Tester

4.9.2 Toys in which an accessible, potentially hazardous sharp point is a necessary function of the toy, such as a needle in a sewing kit, shall carry cautionary labeling as specified in 5.10, if the toy is intended for children from 48 to 96 months old. Toys intended for children less than 48 months old shall not have accessible hazardous functional points.

4.9.3 *Wood*—The accessible surfaces and edges of wood used in toys shall be free of splinters, both before and after being tested in accordance with the appropriate procedures described in 8.5-8.10.

4.10 *Wires or Rods*—Wires or rods used in the interior of toys shall have their ends finished to avoid potentially hazardous points and burrs, shall be turned back, or shall be covered with smoothly finished protective caps or covers, if they can become accessible after use or reasonably foreseeable abuse. Metal wires or other metal materials used for stiffening or for retention of form in toys shall not fracture to produce a hazardous point, edge, or projection hazard when tested in accordance with 8.12, if the component can be bent through a 60° arc by the applicable maximum force. When applied perpendicularly to the major axis of the component at a point 2 ± 0.05 in. (50 ± 1.3 mm) from the intersection of the component with the main body of the toy or at the end of the component if the component is less than 2 in. (50 mm) long, the maximum force shall be as follows (within a tolerance of ± 0.5 lb (± 0.02 kg)):

10 lbf (45 N)
15 lbf (67 N)

toys intended for use by children 18 months of age or less
toys intended for use by children over 18 but not over 96
months of age

The ends of spokes on toy umbrellas shall be protected. If the protection is removed when tested according to 8.9 (tension test) the ends of the spokes shall be free from sharp edges and sharp points when tested in accordance with 4.7.1 (sharp edge test) and 4.9.1 (sharp point test). Furthermore, if the protective components are removed by the tension test, the spokes shall have a minimum diameter of 0.08 in. (2 mm) and the ends shall be smooth, rounded, and approximately spherical with no burrs.

4.11 *Nails and Fasteners*—Nails and fasteners shall not present a point, edge, ingestion, or projection hazard. Points of nails or fasteners shall not protrude so as to be accessible. Additional requirements for nails and fasteners used as axles are given in 4.17.

4.12 *Packaging Film*—This requirement is intended to minimize the possibility of asphyxiation hazards that might be caused by thin packaging films. Flexible plastic film bags and flexible plastic sheets used as packaging materials for shelf packages or used with toys shall be at least 0.00150 in. (0.03810 mm) in nominal thickness, but the actual thickness shall never be less than 0.00125 in. (0.03175 mm). Alternatively, sheeting with an average thickness of less than 0.00150 in. (0.03810 mm) shall be perforated with defined holes so that a minimum of 1 % of the area has been removed over any area of 1.18×1.18 in. (30×30 mm). The thickness shall be determined using the test method in 8.22. This requirement does not apply to the following:

4.12.1 Shrink film in the form of an over wrap that would normally be destroyed when the package is opened by a consumer.

4.12.2 Bags or plastic film with a minor dimension of 3.94 in. (100 mm) or less. Bag dimensions shall be measured while in the form of a bag, not cut open into a single thickness sheet.

4.13 *Folding Mechanisms and Hinges*—These requirements are intended to eliminate possible crushing, laceration, or pinching hazards that might occur in folding mechanisms and hinges of toys intended to support the weight of a child. Toys shall meet the requirements specified in 4.13.1 and 4.13.2 after they are tested in accordance with 8.5-8.10. Requirements for toy chests are contained in 4.27.

4.13.1 *Folding Mechanisms*—Toy furniture and other toys in which a folding mechanism, arm, or bracing is intended to support a child shall have a safety stop or locking device to prevent unexpected or sudden movement or collapse of the article, or have adequate clearance to provide protection for the fingers, hands, and toes from crushing, laceration or pinching hazards in the event of sudden movement or collapse of the article.

4.13.2 *Hinge-Line Clearance*—Toys having a gap or clearance along the hinge line between a stationary portion and a moveable portion that weighs more than $\frac{1}{2}$ lb (0.2 kg) shall be so constructed that, if the accessible gap at the hinge line will admit a $\frac{3}{16}$ -in. (5-mm) diameter rod, it will also admit a $\frac{1}{2}$ -in. (13-mm) diameter rod at all positions of the hinge.

4.14 *Cords, Straps, and Elastics*—These requirements are intended to minimize the potential entanglement and strangulation hazards that might be caused by accessible cords, straps, and elastics. These requirements are applicable before and after use and abuse testing in accordance with 8.5-8.10.

4.14.1 *Cords, Straps, and Elastics in Toys*—Cords or elastics included with or attached to toys intended for children less than 18 months of age (excluding pull toys, see 4.14.3) shall be less than 12 in. (300 mm) long when measured to the maximum length in a free state and under a load of 5 lb (2.25 kg). If cords/straps/elastics or multiple cords/straps/elastics can tangle or form a loop in connection with any part of the toy, including beads or other attachments on the ends of cords/straps/elastics, the loop shall not permit the passage of the head probe (Fig. 11) when tested in accordance with 8.23. Specifically, the loop shall not allow the head probe to be inserted so deep that it admits the base of the probe. The configuration of the loop shall be determined by using all components that make up the loop. For example, the configuration of the loop for the product illustrated in Fig. 12 is comprised of Cord 1, Cord 2, and the toy part.

4.14.1.1 *Cords, Straps, and Elastics Containing a Breakaway Feature*—Cords, straps, and elastics on toys that have loops that admit the base of the head probe shall contain a functional breakaway feature that prevents entanglement by releasing at a force less than 5.0 lbf (22.2 N) when tested in accordance with 8.23.3. The free length of the individual released cord, strap, or elastic should not exceed a maximum length of 12 in. (300 mm). The breakaway feature shall be capable of being reattached without altering the characteristics of the attachment.