International Standard



1005/9

INTERNATIONAL ORGANIZATION FOR STANDARDIZATION • МЕЖДУНАРОДНАЯ ОРГАНИЗАЦИЯ ПО СТАНДАРТИЗАЦИИ • ORGANISATION INTERNATIONALE DE NORMALISATION

**Railway rolling stock material —
Part 9 : Axles for tractive and trailing stock —
Dimensional requirements**

Matériel roulant de chemin de fer — Partie 9 : Essieux-axes pour matériel moteur et matériel remorqué — Prescriptions dimensionnelles

iTeh STANDARD PREVIEW

First edition — 1986-11-15

(standards.iteh.ai)

[ISO 1005-9:1986](https://standards.iteh.ai/catalog/standards/sist/23599208-97a1-484c-857a-0a0415959305/iso-1005-9-1986)

<https://standards.iteh.ai/catalog/standards/sist/23599208-97a1-484c-857a-0a0415959305/iso-1005-9-1986>

UDC 629.4.027.11

Ref. No. ISO 1005/9-1986 (E)

Descriptors : railway equipment, railway rolling stock, steel products, axles, specifications, dimensions, acceptance testing.

Foreword

ISO (the International Organization for Standardization) is a worldwide federation of national standards bodies (ISO member bodies). The work of preparing International Standards is normally carried out through ISO technical committees. Each member body interested in a subject for which a technical committee has been established has the right to be represented on that committee. International organizations, governmental and non-governmental, in liaison with ISO, also take part in the work.

Draft International Standards adopted by the technical committees are circulated to the member bodies for approval before their acceptance as International Standards by the ISO Council. They are approved in accordance with ISO procedures requiring at least 75 % approval by the member bodies voting.

International Standard ISO 1005/9 was prepared by Technical Committee ISO/TC 17, *Steel*.

Users should note that all International Standards undergo revision from time to time and that any reference made herein to any other International Standard implies its latest edition, unless otherwise stated.

iTeh STANDARD PREVIEW
(standards.iteh.ai)

ISO 1005-9:1986
https://standards.iteh.ai/Standard/ISO/ISO-97a1-484c-857a-0a0415959305/iso-1005-9-1986

Railway rolling stock material — Part 9 : Axles for tractive and trailing stock — Dimensional requirements

1 Scope and field of application

1.1 This part of ISO 1005 specifies

- a) The dimensional requirements¹⁾ in the various stages, shown in figure 1 (see table 1) and figure 2 (see table 2), see also 5.1;
- b) the surface roughnesses, shown in figure 2 (see table 3), see also 5.2, of axles for tractive and trailing stock.

1.2 The quality requirements for axles for railway rolling stock are given in ISO 1005/3.

1.3 In addition to the requirements of this part of ISO 1005, the general technical delivery requirements of ISO 404 apply.

1.4 The dimensional requirements¹⁾ and surface finishes of heavy freight vehicle axles (i.e. exceeding 22 000 kg axle-load) or of axles for speeds under 100 km/h shall be subject to agreement between the purchaser and manufacturer at the time of enquiry and order.

2 References

ISO/R 286, *ISO system of limits and fits — Part 1: General, tolerances and deviations.*

ISO 404, *Steel and products — General technical delivery requirements.*

ISO 468, *Surface roughness — Parameters, their values and general rules for specifying requirements.*

ISO 1005, *Railway rolling stock material*

— *Part 3: Axles for tractive and trailing stock — Quality requirements.*

— *Part 7: Wheelsets for tractive and trailing stock — Quality requirements.*

ISO 1101, *Technical drawings — Geometrical tolerancing — Tolerancing of form, orientation, location and run-out — Generalities, definitions, symbols, indication on drawings.*

3 Information to be supplied by the purchaser

The purchaser shall supply the following information regarding dimensional and roughness requirements in his enquiry and order:

- a) the number of this part of ISO 1005;
- b) a dimensioned drawing;
- c) in which speed range it is intended that the axle will operate, i.e. normal (N) or high speed (H);
- d) the degree of finish (see clause 4);
- e) the dimensional requirements and surface finishes (see 1.4) and roughness values if they deviate from this part of ISO 1005;
- f) the roughness values if R_y is to be used [see table 3, footnote 2)];
- g) if specific geometrical tolerances are required (see 5.1.3.2 and 6.1);
- h) if one of the optional verifications is required (see 6.1 and table 2).

4 Terms for the degree of finish

The various conditions of axle and stages of manufacture referred to in this part of ISO 1005 are given in 4.1 to 4.5.

4.1 Unmachined

For forged or rolled axles, "unmachined" indicates the "black" axle with no subsequent machining other than that which may be carried out by the manufacturer to enable the axle to conform to the required standard.

4.2 Rough machined

In accordance with ISO 1005/3, "rough machined" indicates a condition in which the axle has received no final machining, but has been rough machined on all, or only certain portions, which have to be machined.

1) The term "dimensional requirements" covers machining allowances, dimensional tolerances and tolerances of form and position.

4.3 Half finished

In accordance with ISO 1005/3, "half finished" indicates a condition in which the axle has received final machining on certain portions which have to be machined and are considered as finished, whereas other portions are unmachined or rough-machined.

4.4 Finished

In accordance with ISO 1005/3, "finished" indicates the axle condition in which all portions of the axle which are required, by the order or drawing, to be machined have undergone all machining operations other than those normally carried out by the wheelset manufacturer immediately before mounting the wheel on the axle, for example finishing of wheelseat.

4.5 Ready for assembly

"Ready for assembly" indicates the axle condition in which all necessary machining operations have been carried out.

5 Requirements

5.1 Dimensional requirements

5.1.1 For "unmachined" portions of axles, the dimensional requirements shall be as indicated on figure 1 and in table 1.

5.1.2 For "rough machined" and "half finished" portions of axles, the dimensional requirements shall be agreed at the time of enquiry and order.

5.1.3 For "finished" portions of axles (see 4.4) and for axles in the "ready for assembly" condition (see 4.5), the dimensional requirements shall be as indicated in table 2 and in 5.1.3.1 and 5.1.3.2.

5.1.3.1 The manufacturer shall take care that for all relevant geometrical characteristics the tolerances are maintained such that, when the wheels are assembled on to the axle (see 1005/7) the tolerance values of the wheelset as required in ISO 1005/7 are achieved without further machining.

5.1.3.2 If in special cases, despite the difficulties mentioned in 6.1, instead of the requirements of 5.1.3.1 specific geometrical tolerances of the axle are required for the compliance of the axle with the order, this shall be agreed at the time of enquiry and order. In this case, the geometrical tolerances shown in table 2 shall apply, unless otherwise agreed.

5.2 Surface roughness

Unless otherwise agreed, the arithmetic mean deviation of the profile, R_a , for machined surfaces in the "finished" and "ready for assembly" conditions shall be as indicated on figure 2 and in table 3.

5.3 Turning centres

The axles shall, in "finished" and "ready for assembly" conditions, have turning centres machined in accordance with the purchaser's order or drawing accompanying the order.

6 Inspection

6.1 Dimensional characteristics

Where in tables 1 and 2, last column, an "m" is indicated, the verification of the corresponding dimensional requirement is mandatory. Because of the practical difficulties of verification of certain dimensional values under production conditions, the dimensional characteristics for which an "o" is indicated in the last column of table 2 shall only be verified if agreed at the time of enquiry and order (see also 5.1.3.2). Definition of the various geometrical tolerance terms are given in ISO 1101.

6.2 Surface roughness

If compliance with the requirements for the surface roughness is to be verified, the number of axles to be inspected and all other necessary details shall be agreed at the time of enquiry and order.

iTeh STANDARD PREVIEW
(standards.itel.f.ai)

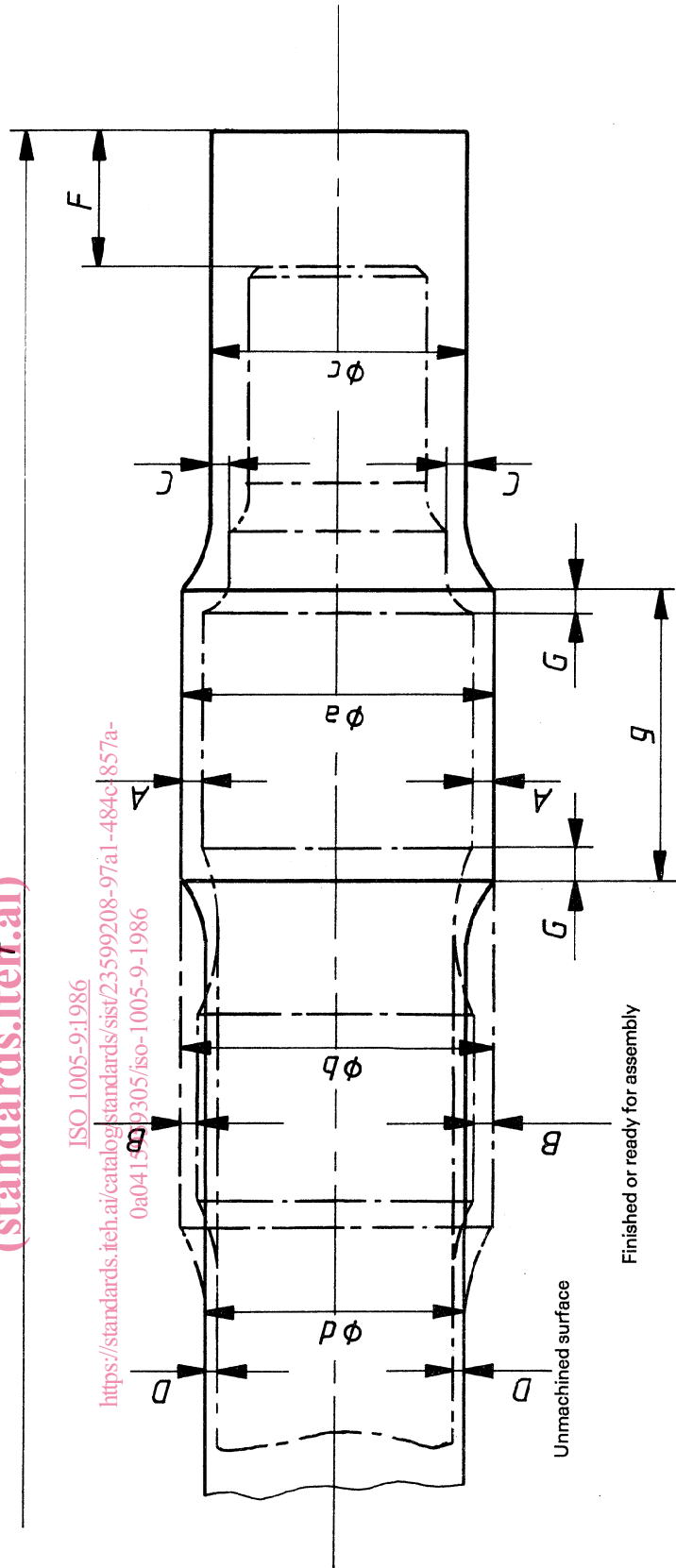

ISO 1005-9:1986
<https://standards.iteh.ai/catalog/standards/sist/23599208-97/a1-484c1857a-0a041599305/iso-1005-9-1986>

Figure 1 — Symbols for the dimensional characteristics, specified in table 1 for unmachined portions of forged or rolled axes

Table 1 — Dimensional requirements for "unmachined"¹⁾ forged and rolled²⁾ axles

Designation	Symbol in figure 1	Machining allowance (mm)	Tolerance (mm)	Verification ³⁾
Wheel seat diameter	<i>A</i>	5 ⁴⁾		m
	<i>a</i> ⁵⁾		+ 15 0	m
Gear wheel seat diameter, motor suspension bearing seat diameter, etc.	<i>B</i>	5		m
	<i>b</i> ⁵⁾		+ 15 0	m
Abutment and journal diameter	<i>C</i>	5		m
	<i>c</i>		+ 15 0	m
Axle body diameter	<i>D</i>	5		m
	<i>d</i>		+ 15 0	m
Length	<i>F</i>	15		m
	<i>f</i>		+ 140 0 ⁶⁾	m
Wheel seat length (also other seats, for example gear wheel seat, motor suspension bearing seats)	<i>G</i>	20		m
	<i>g</i>		+ 30 0	m
Straightness ⁷⁾				— ⁷⁾

1) Term is defined in 4.1.

2) In the case of axles manufactured from rolled bars, the machining allowance and the tolerance value for symbols *A* — *a*, *B* — *b*, *C* — *c* and *D* — *d* are understood to apply to the larger diameter.

3) m is mandatory.

4) Where a provision for "oversize" wheel seats is required, the machining allowance should be increased by the appropriate amount; if the provision is required but the amount is not specified, the machining allowance shall be 10 mm.

5) It is usual to forge the wheel seat and the gear wheel seat to the same diameter. In this case, the tolerance value is understood to apply to the large diameter only.

6) Normally "unmachined" axles are supplied with sawn ends, in this condition, the appropriate tolerance would be $\begin{matrix} + 10 \\ - 0 \end{matrix}$

7) The unmachined axle should, within the limitations of forging, be straight; in this condition, the accurate checking of this parameter is difficult and therefore no tolerance value for straightness is given. However, the manufacturer shall ensure that the unmachined axles are sufficiently straight to enable the finished axle to be produced from a rough forging, or rolling, to the minimum tolerance values given in the table.

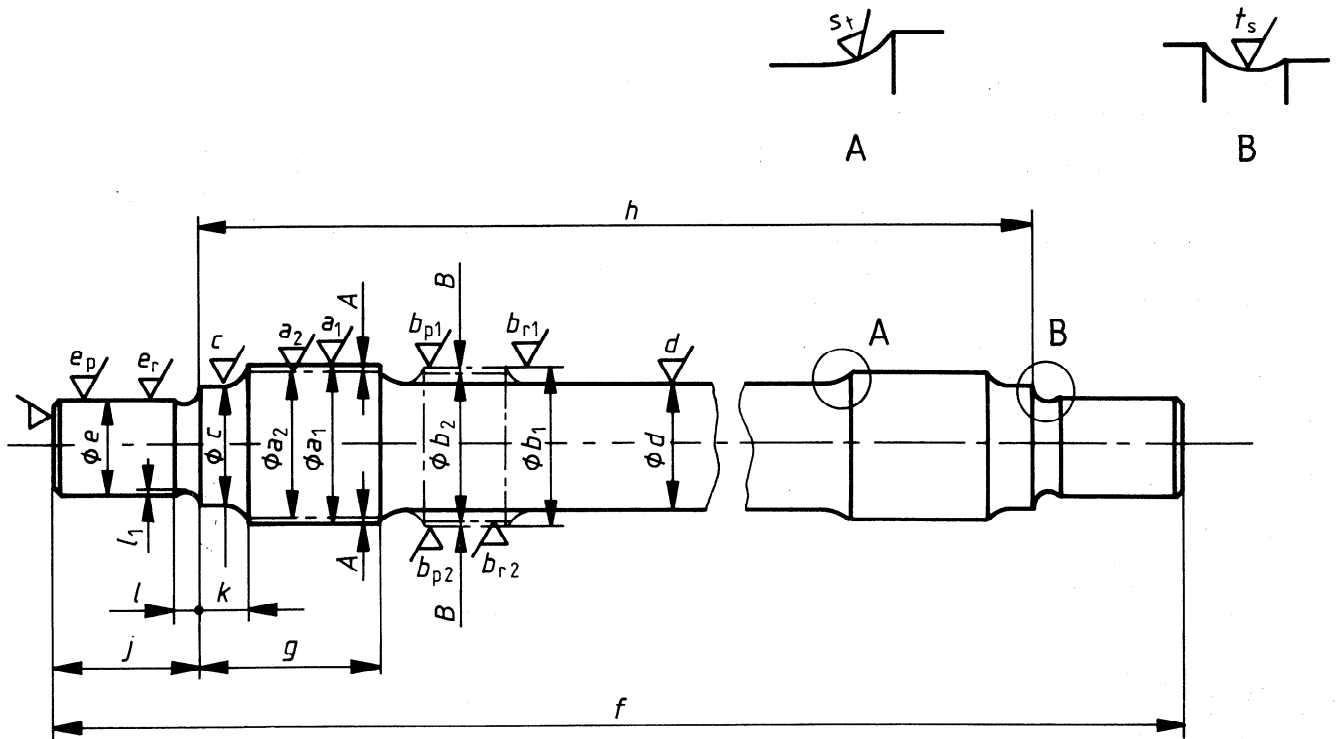

a) Symbols for the dimensional characteristics and surface roughness for "finished" and "ready for assembly" axes

iTeh STANDARD PREVIEW
(standards.iteh.ai)

ISO 1005-9:1986

<https://standards.iteh.ai/catalog/standards/sist/23599208-97a1-4847-857a-16a0415759305/iso-1005-9-1986>

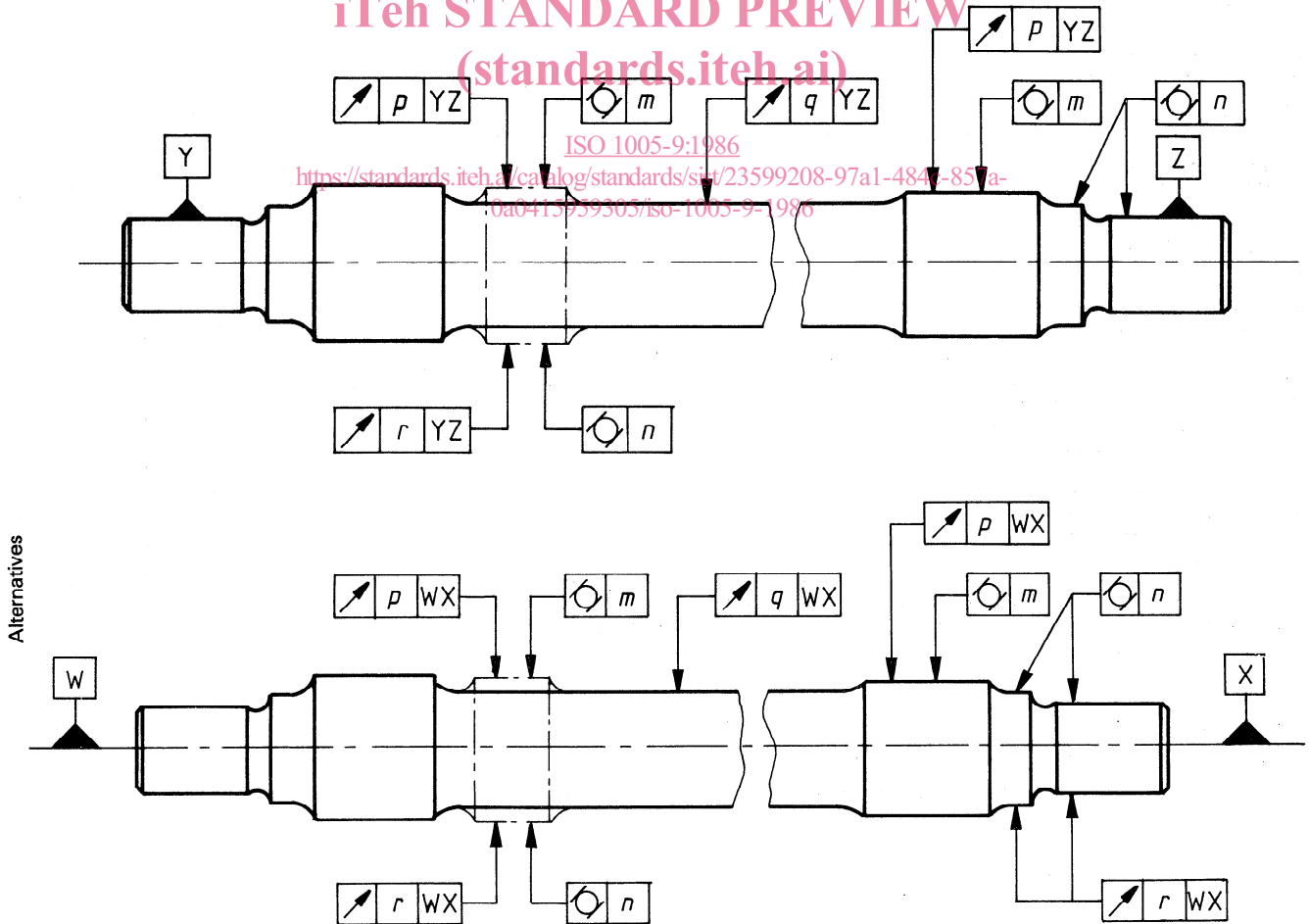

b) Geometrical tolerances relative to datum WX or YZ for "finished" and "ready for assembly" axes

Figure 2

Table 2 – Dimensional requirements¹⁾ for “finished” portions²⁾ and for the condition “ready for assembly”²⁾ of axles

Designation	Symbol in figure 2 a) and b) for dimensional geometrical tolerances		Tolerances (mm)				Verifi- cation ³⁾
			Finished		Ready for assembly		
			Normal speeds	High speeds	Normal speeds	High speeds	
Wheel seat diameter	a_1		+ 2 0	+ 2 0	—	—	m
	a_2		—	—	— ⁴⁾	— ⁴⁾	m
Gear wheel seat diameter, motor suspension bearing seat diameter, etc.	b_1		+ 2 0	+ 2 0	—	—	m
	b_2		—	—	— ⁵⁾	— ⁵⁾	m
Abutment diameter	c		± 0,25 ⁵⁾	± 0,25 ⁵⁾	± 0,25 ⁵⁾	± 0,25 ⁵⁾	m
Axle body diameter	d		+ 2 0	+ 2 0	+ 2 0	+ 2 0	m
Journal diameter (roller)	e_r		— ⁵⁾	— ⁵⁾	— ⁵⁾	— ⁵⁾	m
Journal diameter (plain)	e_p		± 0,1	—	± 0,1	—	m
Length of axle	f		± 1	± 1	± 1	± 1	m
Wheel seat length (including abutment; also other seats, for example gear wheel)	g		0 - 1	0 - 1	0 - 1	0 - 1	m
Length over abutments	h		± 0,5	± 0,5	± 0,5	± 0,5	m
Journal bearing seat length	j		± 0,5 ⁵⁾	± 0,5 ⁵⁾	± 0,5 ⁵⁾	± 0,5 ⁵⁾	m
Abutment length	k		+ 1 0	+ 1 0	+ 1 0	+ 1 0	m
Groove at journal to abutment transition (where applicable)	l		— ⁴⁾	— ⁴⁾	— ⁴⁾	— ⁴⁾	m
	l_1		— ⁴⁾	— ⁴⁾	— ⁴⁾	— ⁴⁾	m
Wheel seat cylindricity (also motor bearing seats)		m	—	—	0,015 ⁶⁾	0,015 ⁶⁾	m
Journal and abutment cylindricity (also motor bearing seats)		n	0,015	0,015	0,015	0,015	m
Wheel seat run-out (also gear wheel seat) relative to datums WX or YZ		p	1,5	1,5	0,05	0,03	o
Axle body run-out relative to datum WX or YZ		q	0,5	0,3	0,5	0,3	o
Journal and abutment run-out relative to datum WX (also motor bearing seats relative to datum WX or YZ)		r	0,05	0,03	0,05	0,03	o

1) The machining allowance A on wheel seat (also B if gear wheel seat is required) to be 3 mm, i.e. $a_1 - a_2 = 6$ mm. For tractive stock, the machining allowance, A, on the wheel seat shall be 5 mm (i.e. 10 mm on diameter).

2) Terms as defined in 4.4 and 4.5.

3) m is mandatory; o is optional.

4) According to the drawing and relevant documents (see also ISO 1005/7 and ISO/R 286).

5) According to the specification of the supplier of the bearings or customer.

6) Any slight taper within the permitted tolerance shall be such that the smaller diameter is at the outer end, i.e. entry to the bore of the wheel on assembly.

Table 3 – Average surface roughness for “finished”¹⁾ and “ready for assembly”¹⁾ axles

Designation	Symbol [see figure 2 a)]	Arithmetic mean deviation of the profile, ²⁾ R_a (μm)	
		Finished condition	Ready for assembly condition
Wheel seat diameter	a_1	$< 12,5$ ³⁾	—
	a_2	—	0,8 to 1,6 ³⁾
Gear wheel seat or motor bearing (roller) seats	b_{r1}	0,8 to 1,6 ³⁾	—
	b_{r2}	—	0,8 to 1,6 ³⁾
Motor bearing (plain) seats	b_{p1}	$< 0,8$ ³⁾	—
	b_{p2}	—	; 0,8 ³⁾
Abutment diameter	c	$\leq 1,6$ ³⁾	$\leq 1,6$ ³⁾
Axle body diameter	d	$\leq 6,3$ ³⁾	$\leq 6,3$ ³⁾
Journal (roller)	e_r	$< 0,8$ ³⁾	$< 0,8$ ³⁾
Journal (plain)	e_p	$< 0,8$ ³⁾	$< 0,8$ ³⁾
Axle end face and chamfer	f	$< 6,3$ ⁴⁾	$< 6,3$ ⁴⁾
Inner transitional radii to wheel seats	s_t	$< 1,6$ ^{3) 5)}	$< 1,6$ ^{3) 5)}
Stress relieving grooves	t_s	$< 0,8$ ³⁾	$< 0,8$ ³⁾

1) Terms as defined in 4.4 and 4.5.

2) If the maximum height of the profile, R_v , (see ISO 468), is used, the values shall be agreed between the interested parties.

3) As measured in direction of longitudinal axis.

4) As measured in direction of vertical axis.

5) For trailer axles, an arithmetical deviation of the profile $R_a < 3,2 \mu\text{m}$ may be applied with the agreement of the customer.