



Standard Test Method for Determination of the Sludging and Corrosion Tendencies of Inhibited Mineral Oils¹

This standard is issued under the fixed designation D 4310; the number immediately following the designation indicates the year of original adoption or, in the case of revision, the year of last revision. A number in parentheses indicates the year of last reapproval. A superscript epsilon (ϵ) indicates an editorial change since the last revision or reapproval.

1. Scope

1.1 This test method is used to evaluate the tendency of inhibited mineral oil based steam turbine lubricants and mineral oil based anti-wear hydraulic oils to corrode copper catalyst metal and to form sludge during oxidation in the presence of oxygen, water, and copper and iron metals at an elevated temperature. The test method is also used for testing circulating oils having a specific gravity less than that of water and containing rust and oxidation inhibitors.

NOTE 1—During round robin testing copper and iron in the oil, water and sludge phases were measured. However, the values for the total iron were found to be so low (that is, below 0.8 mg), that statistical analysis was inappropriate. The results of the cooperative test program are available.²

1.2 This test method is a modification of Test Method D 943 where the oxidation stability of the same kinds of oils is determined by following the acid number of oil. The number of test hours required for the oil to reach an acid number of 2.0 mg KOH/g is the *oxidation lifetime*.

1.3 The values stated in acceptable metric units are to be regarded as the standard.

1.4 *This standard does not purport to address all of the safety concerns, if any, associated with its use. It is the responsibility of the user of this standard to establish appropriate safety and health practices and determine the applicability of regulatory limitations prior to use.* For specific precautionary statements, see Section 7 and X1.1.5.

2. Referenced Documents

2.1 ASTM Standards:

- A 510 Specification for General Requirements for Wire Rods and Coarse Round Wire, Carbon Steel³
- B 1 Specification for Hard-Drawn Copper Wire⁴

- D 329 Specification for Acetone⁵
- D 770 Specification for Isopropyl Alcohol⁵
- D 874 Test Method for Sulfated Ash from Lubricating Oils and Additives⁶
- D 943 Test Method for Oxidation Characteristics of Inhibited Mineral Oils⁶
- D 1193 Specification for Reagent Water⁷
- D 4057 Practice for Manual Sampling of Petroleum and Petroleum Products⁸
- E 1 Specification for ASTM Thermometers⁹
- 2.2 *IP Standard*:¹⁰
Specification for IP Standard Thermometers
- 2.3 *British Standard*:¹¹
BS 1829

3. Terminology

3.1 Definition:

3.1.1 *sludge*—a precipitate or sediment from oxidized mineral oil and water.

4. Summary of Test Method

4.1 An oil sample is contacted with oxygen in the presence of water and an iron-copper catalyst at 95°C for 1000 h. The weight of insoluble material is determined gravimetrically by filtration of the oxidation tube contents through 5- μ m pore size filter disks. The total amount of copper in the oil, water, and sludge phases is also determined.

NOTE 2—Optionally, some operators may choose to: (a) assess the change in weight of the catalyst coil, or (b) determine the acid number at 1000 h, or both. The acid number may serve as a criterion to determine if measurement of insoluble material is warranted. Normally, further testing is not recommended on a highly oxidized oil (that is an oil which has attained an acid number >2.0 mg KOH/gm). Instructions for these optional

¹ This test method is under the jurisdiction of ASTM Committee D-2 on Petroleum Products and Lubricants and is the direct responsibility of Subcommittee D02.09 on Oxidation.

Current edition approved June 10, 1998. Published October 1998. Originally published as D 4310 – 83. Last previous edition D 4310 – 95.

² Available from ASTM Headquarters. Request RR: D02-1291 issued July 14, 1992.

³ *Annual Book of ASTM Standards*, Vol 01.03.

⁴ *Annual Book of ASTM Standards*, Vol 02.03.

⁵ *Annual Book of ASTM Standards*, Vol 06.04.

⁶ *Annual Book of ASTM Standards*, Vol 05.01.

⁷ *Annual Book of ASTM Standards*, Vol 11.01.

⁸ *Annual Book of ASTM Standards*, Vol 05.02.

⁹ *Annual Book of ASTM Standards*, Vol 14.03.

¹⁰ Available from The Institute of Petroleum, 61 New Cavendish St., London W1M, 8AR, England.

¹¹ Available from British Standards Institute, 2 Park St., London, England W1A285.

tests are not included in this test method.

5. Significance and Use

5.1 Insoluble material may form in oils that are subjected to oxidizing conditions.

5.2 Significant formation of oil insolubles or metal corrosion products, or both, during this test may indicate that the oil will form insolubles or corrode metals, or both, during field service. However, no correlation with field service has been established.

6. Apparatus

6.1 *Oxidation Cell*, of borosilicate glass, as shown in Fig. 1,

consisting of a test tube, condenser, and oxygen delivery tube. The test tube has a calibration line at 300 mL (maximum error 1 mL). This calibration applies to the test tube without inserts at 20°C.

6.2 *Heating Bath*, thermostatically controlled, capable of maintaining the oil sample in the oxidation cell at a temperature of $95 \pm 0.2^\circ\text{C}$, fitted with a suitable stirring device to provide a uniform temperature throughout the bath, and large enough to hold the desired number of oxidation cells immersed in the heating bath to a depth of 390 ± 10 mm and in the heating liquid itself to a depth of 355 ± 10 mm.

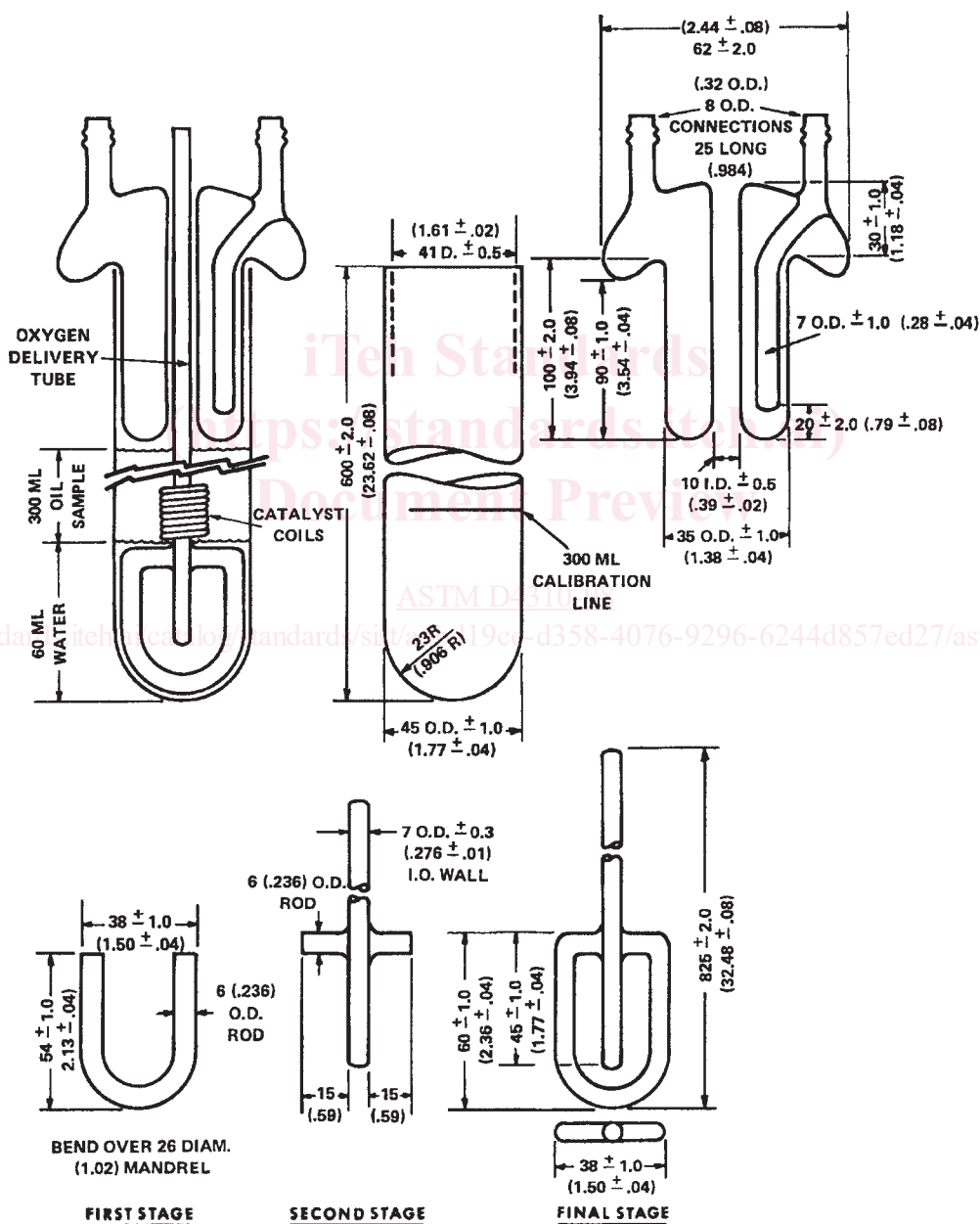

All dimensions are in millimetres (inches)

NOTE 1—The oxidation test tube has a calibration line at 300 ml. This calibration applies to the test tube alone at 20°C.

NOTE 2—Open tube ends to be ground and fire-polished.

FIG. 1 Oxidation Cell

6.2.1 Studies have suggested that direct sunlight or artificial light may adversely influence the results of this test.¹² To minimize effects of light exposure on the lubricant being tested, light shall be excluded from the lubricant by one or more of the following ways:

6.2.1.1 Use of heated liquid baths that are designed and constructed of metal, or combinations of metals and other suitable opaque materials, that prevent light from entering the test cell from the sides is preferred. If a *viewing window* is included in the design, this *viewing window* shall be fitted with a suitable opaque cover and be kept closed when no observation is being made.

6.2.1.2 If glass heating baths are used, the bath shall be wrapped with aluminum foil or other opaque material.

6.2.1.3 Bright light entering the test cell from directly overhead can be eliminated by use of an opaque shield.

6.3 *Flowmeter*, with a flow capacity of at least 3 L of oxygen/hour, and an accuracy of ± 0.1 L/h.

6.4 *Heating Bath Thermometer*—ASTM Solvents Distillation Thermometer having a range from 72 to 126°C and conforming to the requirements for Thermometer 40C as prescribed in Specification E 1, or for Thermometer 70C as prescribed in Specifications for IP Standard Thermometers. Alternatively, temperature-measuring devices of equal or better accuracy may be used.

6.5 *Oxidation Cell Thermometer*,¹³ having a range from 80 to 100°C, graduated in 0.1°C, total length—250 mm, stem diameter—6.0 to 7.0 mm, calibrated for 76-mm immersion.

6.6 *Wire Coiling Mandrel*, as shown in Fig. 2 .

6.7 *Thermometer Bracket*, for holding the oxidation cell thermometer, of 18-8 stainless steel, having the dimensions shown in Fig. 3 . The thermometer is held in the bracket by two fluoro-elastomer O-rings of approximately 5-mm inside diameter. Alternatively, thin stainless steel wire may be used.

6.8 *Abrasive Cloth*, silicon carbide, 100-grit with cloth backing.

6.9 *Flexible Tubing*, poly vinyl chloride approximately 6.4-mm (1/4-in.) inside diameter with a 3/32-in. wall for delivery of oxygen to the oxidation cell.

6.10 *Membrane Filters*,¹⁴ white, plain, 47 mm in diameter, pore size 5 μ m.

6.11 *Filter Holder*,¹⁵ 47 mm, consisting of a borosilicate glass funnel and a funnel base with a coarse grade (40 to 60- μ m) fritted-glass filter support or stainless steel screen support such that the filter can be clamped between the ground-glass sealing surfaces of the funnel and its base by means of a metal clamp.

6.12 *Weighing Bottle*,¹⁶ cylindrical body with ground-glass stopper; approximate inside diameter 45 mm, height of body 65 mm, capacity 60 mL.

6.13 *Vacuum Source*, to provide pressure reduction to 13.3 ± 0.7 kPa (100 ± 5 mm Hg) absolute pressure.

6.14 *Cooling Vessel*—A desiccator or other type of tightly covered vessel for cooling the weighing vessels before weighing. The use of a drying agent is not recommended.

6.15 *Drying Oven*, capable of maintaining a temperature of $105 \pm 2^\circ\text{C}$.

6.16 *Forceps*, having unserrated tips.

6.17 *Syringe*, 50-mL Luer-Lok with 12-in. needle.

6.18 *Separatory Funnels*, with a capacity of 1000 mL.

6.19 *Rubber Policeman*.

7. Reagents and Materials

7.1 *Purity of Reagents*—Reagent grade chemicals shall be used in all tests. Unless otherwise indicated, it is intended that all reagents conform to the specifications of the Committee on Analytical Reagents of the American Chemical Society where such specifications are available.¹⁷ Other grades may be used, provided it is first ascertained that the reagent is of sufficiently high purity to permit its use without lessening the accuracy of the determination.

7.2 *Purity of Water*—Unless otherwise indicated, references to water shall be understood to mean reagent water as defined by Type II of Specification D 1193.

7.3 *Acetone* (**Warning**—Health hazard, flammable.), 99.5 % Grade, conforming to Specification D 329.

7.4 *Cleaning Reagent*, cleaning by a 24-h soak at room temperature in either Nochromix¹⁸ (**Warning**—Corrosive, health hazard) or in Micro¹⁹ solution.

7.5 *n-Heptane*, Reagent grade. (**Warning**—Flammable. Harmful if inhaled.)

7.6 *Hydrochloric Acid* (**Warning**—Toxic and corrosive.), concentrated [(36 mass % (relative density 1.19)].

7.7 *Isopropyl Alcohol* (**Warning**—Flammable.), conforming to Specification D 770.

7.8 *Catalyst Wires*:

7.8.1 *Low-Metalloid Steel Wire*,²⁰ 1.59 mm (0.0625 in.) in diameter (No. 16 Washburn and Moen Gage).

7.8.2 *Electrolytic Copper Wire*, 1.63 mm (0.064 in.) in diameter (No. 16 Imperial Standard Wire Gage or No. 14

¹² A summary of the results of these studies is available from ASTM Headquarters. Request RR:D02-1365.

¹³ Brooklyn Thermometer No. 21276-RM, available from Brooklyn Thermometer Co., Farmingdale, NY, or equivalent has been found satisfactory for this purpose.

¹⁴ Millipore SM membrane filters (MF-type, cellulose esters), available from Millipore Filter Corp., Bedford MA, or equivalent have been found satisfactory.

¹⁵ Millipore Pyrex XX-10-047-00 or XX-10-047-30 filter holder, available from Millipore Filter Corp., or equivalent have been found satisfactory for this purpose.

¹⁶ Fisher 3-415 weighing bottle, size G, available from Fisher Scientific Co., Pittsburgh, PA., or equivalent, has been found satisfactory for this purpose.

¹⁷ *Reagent Chemicals, American Chemical Society Specifications*, American Chemical Society, Washington, DC. For suggestions on the testing of reagents not listed by the American Chemical Society, see *Analar Standards for Laboratory Chemicals*, BDH Ltd., Poole, Dorset, U.K., and the *United States Pharmacopeia and National Formulary*, U.S. Pharmacopeial Convention, Inc. (USPC), Rockville, MD.

¹⁸ Nochromix is available from Godax Laboratories, Inc., 720-B Erie Avenue, Takoma Park, MD 20912.

¹⁹ Micro is available from International Products Corp., P.O. Box 70, Burlington, NJ 08016.

²⁰ Carbon steel wire, soft bright annealed and free from rust of Grade 1008 as described in Specification A 510 is satisfactory. Similar wire conforming to BS1829, is also satisfactory. If these steels are not available, other equivalent steels may be used, provided they are found to be satisfactory in comparative tests using this Test Method D 4310.

ASTM D 4310 - 98

American Wire Gage), 99.9 % purity, conforming to Specification B 1. Soft copper wire of an equivalent grade may also be used.

NOTE 3—Alternatively, suitably prepared catalyst coils may be purchased from a supplier.

7.9 Detergent, water-soluble.²¹
 7.10 Oxygen—(Warning—Oxygen vigorously accelerates combustion) 99.5 % minimum purity, with pressure regulation

²¹ Alconox has been found satisfactory for this purpose.

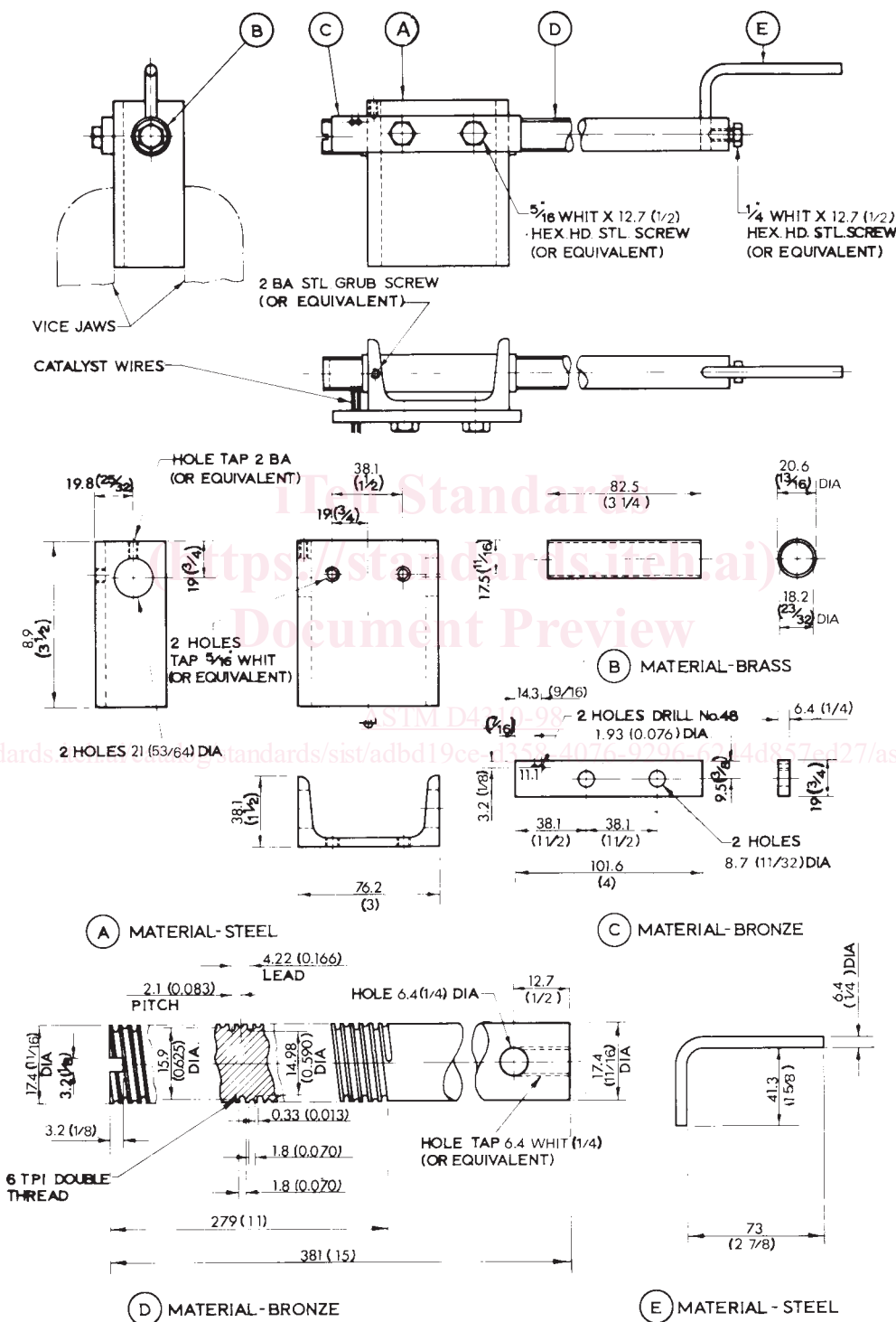

Dimensions are in millimetres (inches).
FIG. 2 Mandrel for Winding Catalyst Coils

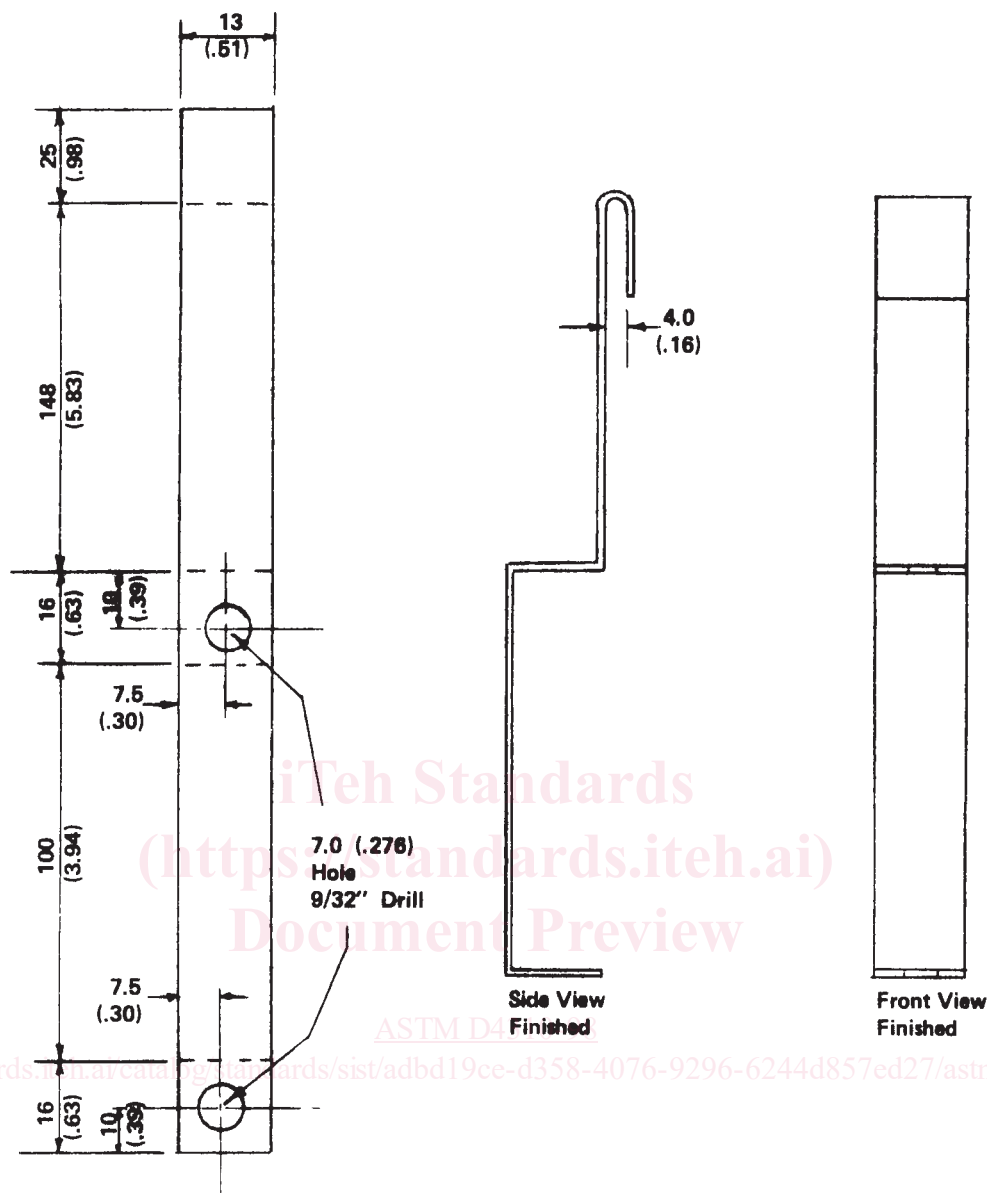

All dimensions are in millimetres (inches).
Material: 18-8 Stainless Steel, 22 Gage (0.792 mm).

FIG. 3 Thermometer Bracket

adequate to maintain a constant flow of gas through the apparatus. The use of a two-stage pressure regulator on tank oxygen is recommended.

8. Sampling

8.1 Samples for this test can come from tanks, drums, small containers, or even operating equipment. Therefore, use the applicable apparatus and techniques described in Test Method D 4057.

8.2 For one single determination the minimum required sample size is 300 mL.

9. Preparation of Apparatus

9.1 *Cleaning Catalyst*—Immediately prior to winding a catalyst coil, clean a 3.00 ± 0.01 -m length of iron wire and an

equal length of copper wire with wads of absorbent cotton wet with *n*-heptane and follow by abrasion with abrasive cloth until a fresh metal surface is exposed. Then wipe with dry absorbent cotton until all loose particles of metal and abrasive have been removed. In subsequent operations handle the catalyst wires with clean gloves (cotton, rubber, or plastic) to prevent contact with the skin.

9.2 *Preparation of Catalyst Coil*—Twist the iron and copper wires tightly together at one end for three turns and then wind them simultaneously alongside each other on a threaded mandrel (see Fig. 2), inserting the iron wire in the deeper thread. Remove the coil from the mandrel, twist the free ends of the iron and copper wires together for three turns, and bend the twisted ends to conform to the shape of the spiral coil. The

overall length of the finished coil should be 225 ± 5 mm (8.9 ± 0.2 in.). If necessary, the coil may be stretched to give the required length (Note 3 and Note 4).

NOTE 4—The finished catalyst coil is a double spiral of copper and iron wire, 225 ± 5 mm (8.9 ± 0.2 in.) overall length and 15.9 to 16.5 mm (0.625 to 0.650 in.) inside diameter. The turns of wire are evenly spaced, and two consecutive turns of the same wire are 3.96 to 4.22 mm (0.156 to 0.166 in.) apart, center to center. The mandrel shown in Fig. 2 is designed to produce such a coil. Using this mandrel, the iron wire is wound on a thread of 14.98 mm (0.590 in.) diameter, while the copper wire is wound on a thread of 15.9-mm (0.625-in.) diameter. The smaller diameter is to allow for “springback” of the steel wire after winding, so as to give 15.9-mm consistent inside diameter. Use of a very soft annealed steel wire may allow use of identical thread diameters for the two wires. Any arrangement that leads to the coil configuration described above is satisfactory.

9.3 *Catalyst Storage*—The catalyst coil may be stored in a dry, inert atmosphere prior to use. A suitable procedure for catalyst storage is given in Appendix X1. Before use it should be inspected to assure that no corrosion products or contaminating materials are present. For overnight storage (less than 24 h) the coil may be stored in *n*-heptane.

9.3.1 *n*-Heptane used for catalyst storage must be free of traces of water and corrosive materials. Redistilled *n*-heptane conforming to 7.5 and stored in a tightly sealed bottle is suitable.

9.4 *Cleaning New Glassware*—Wash new oxygen delivery tubes, condensers, and test tubes with a hot detergent solution and rinse thoroughly with tap water. Clean the interiors of the test tubes, exteriors of the condensers, and both interiors and exteriors of the oxygen delivery tubes with a cleaning reagent. Rinse thoroughly with tap water until all cleaning solution is removed. Rinse all parts with reagent water and allow to dry at room temperature or in an oven. The final reagent water rinse may be followed by an isopropyl alcohol rinse, or acetone rinse optionally followed by dry air blowing to hasten drying at room temperature.

9.5 *Cleaning Used Glassware*—Immediately following termination of a test, drain the oil completely from the test tube. Rinse all the glassware with *n*-heptane to remove traces of oil, wash with a hot detergent solution using a long-handled brush, and rinse thoroughly with tap water. If deposits still adhere to the glassware, a method that has been found useful is to fill the test tubes with detergent solution, insert the oxygen delivery tubes and condensers, and place the tubes in the bath at test temperature. Several hours soaking in this manner often serves to loosen all adhering deposits except iron oxide. Subsequent rinsing with hot (50°C) hydrochloric acid will serve to remove iron oxide. After all deposits are removed, rinse all glassware with a cleaning reagent. Rinse thoroughly with tap water until all cleaning reagent is removed. Rinse all parts with reagent water and allow to dry at room temperature or in an oven. The final reagent water rinse may be followed by an isopropyl alcohol rinse, or acetone rinse optionally followed by dry air blowing, to hasten drying at room temperature. Store glassware in a dry dust-free condition until ready to use.

10. Procedure for Oxidizing the Oil

10.1 Adjust the heating bath to a temperature high enough to maintain the oil in the oxidation test cell at the required temperature of $95 \pm 0.2^{\circ}\text{C}$.

10.2 Fill the empty oxidation test tube with 300 mL of the oil sample to the graduation mark. Slide the catalyst coil over the inlet of the oxygen delivery tube. If the wires are uneven at one end of the coil, position the coil so that this end is down. Place the oxygen delivery tube with the coil into the test tube. Place the condenser over the oxygen delivery tube and test tube. Immerse the test tube in the heating bath. Adjust the heating bath liquid level so that the tube is immersed in the liquid to a depth of 355 ± 10 mm. Connect the condenser to the cooling water. The temperature of the outlet water should not exceed 32°C at any time during the test.

10.3 Connect the oxygen delivery tube to the oxygen supply (see 7.10) through the flowmeter using new poly vinyl chloride flexible tubing no more than 600 mm in length. Before using, the interior of the new tubing should be rinsed with *n*-heptane and blown dry with air. Adjust the rate of flow to 3 ± 0.1 L and continue flow for 30 min.

10.4 Raise the condenser unit from the oxidation cell and add 60 mL of reagent water through the opening thus provided. The test is considered to start at this point.

10.5 Throughout the duration of the test, maintain the temperature of the oil-water mixture (sample temperature) at $95 \pm 0.2^{\circ}\text{C}$ in each test cell with oxygen flowing. Accomplish this by maintaining the bath at the temperature that is found necessary to give the required 95°C sample temperature. The temperature of the bath is always higher than the sample temperature due to the cooling effect of the oxygen gas flow, and depends on heating bath medium, capacity, circulation, and on the number of tests cells in the bath. Measure the sample temperature by a thermometer positioned in the oxidation cell by a thermometer bracket, as in Fig. 4 (see Note 5). Make temperature measurements only with new oil samples, and preferably with dummy cells used specifically for temperature measurement. When an actual test sample is used, remove the thermometer immediately after temperature measurement is complete. Check the temperature in this way in various parts of a multiple-cell bath to verify uniformity of temperature control. Once the required bath temperature is found, maintain at that temperature $\pm 0.2^{\circ}\text{C}$.

NOTE 5—With the arrangement shown in Fig. 4, the 76-mm immersion point of the thermometer is positioned at the oil surface. To allow for heating of the stem portion of the thermometer above the immersion point in the upper portion of the test cell, subtract 0.10°C from the thermometer reading to obtain the true test temperature.

10.6 Add additional reagent water to the oxidation cell as required (see Note 6), at least every 2 weeks during the test, to restore the water level to the shoulder of the oxygen delivery tube. Add the water using the sampling tube and the 50-mL capacity syringe.

NOTE 6—Under some circumstances, the level of water cannot be observed because of deposits or emulsion formation. Marking the upper oil level of the filled oxidation tube by some suitable means and maintaining this level by periodic water additions will keep the proper amount of water in the cell. The correct level for water additions may, if