



# SLOVENSKI STANDARD

## SIST ISO 2971:2014

01-januar-2014

Nadomešča:  
SIST ISO 2971:1998

---

**Cigarete in filtri - Določevanje nazivnega premera - Metoda uporabe nekontaktnih optičnih merilnih naprav**

Cigarettes and filter rods - Determination of nominal diameter - Method using a non-contact optical measuring apparatus

**iTeh STANDARD PREVIEW**  
**(standards.iteh.ai)**

Cigarettes et bâtonnets-filtres - Détermination du diamètre nominal - Méthode utilisant un instrument de mesure optique sans contact

<https://standards.iteh.ai/catalog/standards/sist/7a76c116-a219-4740-a20a-4cc46e0e8cbd/sist-iso-2971-2014>

**Ta slovenski standard je istoveten z: ISO 2971:2013**

---

**ICS:**

65.160

Tobak, tobačni izdelki in oprema

Tobacco, tobacco products and related equipment

**SIST ISO 2971:2014**

**en,fr**

**iTeh STANDARD PREVIEW**  
**(standards.iteh.ai)**

SIST ISO 2971:2014

<https://standards.iteh.ai/catalog/standards/sist/7a76c116-a219-4740-a20a-4cc46e0e8cbd/sist-iso-2971-2014>

INTERNATIONAL  
STANDARD

ISO  
2971

Fourth edition  
2013-04-01

---

---

**Cigarettes and filter rods —  
Determination of nominal diameter —  
Method using a non-contact optical  
measuring apparatus**

*Cigarettes et bâtonnets-filtres — Détermination du diamètre nominal —  
Méthode utilisant un instrument de mesure optique sans contact*

**iTeh STANDARD PREVIEW**  
**(standards.iteh.ai)**

[SIST ISO 2971:2014](https://standards.iteh.ai/catalog/standards/sist/7a76c116-a219-4740-a20a-4cc46e0e8cbd/sist-iso-2971-2014)

<https://standards.iteh.ai/catalog/standards/sist/7a76c116-a219-4740-a20a-4cc46e0e8cbd/sist-iso-2971-2014>



Reference number  
ISO 2971:2013(E)

© ISO 2013

## iTeh STANDARD PREVIEW (standards.iteh.ai)

SIST ISO 2971:2014

<https://standards.iteh.ai/catalog/standards/sist/7a76c116-a219-4740-a20a-4cc46e0e8cbd/sist-iso-2971-2014>



### **COPYRIGHT PROTECTED DOCUMENT**

© ISO 2013

All rights reserved. Unless otherwise specified, no part of this publication may be reproduced or utilized otherwise in any form or by any means, electronic or mechanical, including photocopying, or posting on the internet or an intranet, without prior written permission. Permission can be requested from either ISO at the address below or ISO's member body in the country of the requester.

ISO copyright office  
Case postale 56 • CH-1211 Geneva 20  
Tel. + 41 22 749 01 11  
Fax + 41 22 749 09 47  
E-mail [copyright@iso.org](mailto:copyright@iso.org)  
Web [www.iso.org](http://www.iso.org)

Published in Switzerland

# Contents

Page

Foreword.....	iv
<b>1 Scope.....</b>	<b>1</b>
<b>2 Normative references.....</b>	<b>1</b>
<b>3 Terms and definitions.....</b>	<b>1</b>
<b>4 Principle.....</b>	<b>2</b>
<b>5 Apparatus.....</b>	<b>2</b>
<b>6 Sampling.....</b>	<b>3</b>
<b>7 Procedure.....</b>	<b>3</b>
7.1 Preparation of test pieces.....	3
7.2 Adjustment and calibration.....	4
7.3 Measurement.....	4
<b>8 Expression of results.....</b>	<b>4</b>
<b>9 Repeatability and reproducibility.....</b>	<b>5</b>
<b>10 Test report.....</b>	<b>5</b>
<b>Annex A (normative) Calibration standards.....</b>	<b>7</b>
<b>Annex B (informative) Measurement principle and required number of scans.....</b>	<b>8</b>
<b>Annex C (informative) Information on possible source of measurement error.....</b>	<b>10</b>
<b>Annex D (informative) Non-contact measurement techniques.....</b>	<b>12</b>
<b>Annex E (informative) Alternative measurement techniques for the determination of nominal diameter of cigarettes and filter rods.....</b>	<b>15</b>
<b>Annex F (informative) Protocol for ISO/TC 126/SC 1/WG 2 interlaboratory diameter measurement uncertainty study.....</b>	<b>17</b>

**ISO 2971:2013(E)****Foreword**

ISO (the International Organization for Standardization) is a worldwide federation of national standards bodies (ISO member bodies). The work of preparing International Standards is normally carried out through ISO technical committees. Each member body interested in a subject for which a technical committee has been established has the right to be represented on that committee. International organizations, governmental and non-governmental, in liaison with ISO, also take part in the work. ISO collaborates closely with the International Electrotechnical Commission (IEC) on all matters of electrotechnical standardization.

International Standards are drafted in accordance with the rules given in the ISO/IEC Directives, Part 2.

The main task of technical committees is to prepare International Standards. Draft International Standards adopted by the technical committees are circulated to the member bodies for voting. Publication as an International Standard requires approval by at least 75 % of the member bodies casting a vote.

Attention is drawn to the possibility that some of the elements of this document may be the subject of patent rights. ISO shall not be held responsible for identifying any or all such patent rights.

ISO 2971 was prepared by Technical Committee ISO/TC 126, *Tobacco and tobacco products*, Subcommittee SC 1, *Physical and dimensional tests*.

This fourth edition cancels and replaces the third edition (ISO 2971:1998), which has been technically revised.

**iTeh STANDARD PREVIEW**  
**(standards.iteh.ai)**

[SIST ISO 2971:2014](https://standards.iteh.ai/catalog/standards/sist/7a76c116-a219-4740-a20a-4cc46e0e8cbd/sist-iso-2971-2014)

<https://standards.iteh.ai/catalog/standards/sist/7a76c116-a219-4740-a20a-4cc46e0e8cbd/sist-iso-2971-2014>

# Cigarettes and filter rods — Determination of nominal diameter — Method using a non-contact optical measuring apparatus

## 1 Scope

This International Standard specifies a non contact, optical method of gauging for determination of the mean, minimum and maximum diameters and the ovality (or roundness) of rod-shaped objects with a nominally circular or oval cross section that is convex curvilinear. The method is applicable, in particular, to cigarettes and filter rods.

NOTE 1 Non-contact measurement techniques are discussed in [Annex D](#).

NOTE 2 Alternative contact or pneumatic methods may be used but should be considered as secondary methods and do not come within the scope of the standard. These alternative measurement techniques are discussed in [Annex E](#).

## 2 Normative references

The following documents, in whole or in part, are normatively referenced in this document and are indispensable for its application. For dated references, only the edition cited applies. For undated references, the latest edition of the referenced document (including any amendments) applies.

ISO 3402, *Tobacco and tobacco products — Atmosphere for conditioning and testing*

ISO 5725-2:1994, *Accuracy (trueness and precision) of measurement methods and results — Part 2: Basic method for the determination of repeatability and reproducibility of a standard measurement method*

## 3 Terms and definitions

For the purposes of this International Standard, the following terms and definitions apply.

### 3.1

#### **diameter**

arithmetic mean value of  $n$  apparent diameters measured on a test piece following the method specified in this International Standard, which represents the diameter of a circle with the same circumference as the perimeter of the sample being measured, provided that the boundary of its cross section is convex

Note 1 to entry: The result of the measurement can be affected by  $n$ , the number of readings taken.

### 3.2

#### **convex cross section**

a cross section where the straight line between any two points from the section is also included within the section

### 3.3

#### **perimeter**

length of the line that is the boundary of the cross section

Note 1 to entry: Errors will exist in the estimated value of the perimeter if the sample is not circular. The error will increase as the ovality increases.

### 3.4

#### **circumference**

perimeter of a circular cross section

## ISO 2971:2013(E)

## 3.5

**minimum diameter**

minimum value obtained from the results of  $n$  individual readings performed on a test piece

## 3.6

**maximum diameter**

maximum value obtained from the results of  $n$  individual readings performed on a test piece

## 3.7

**absolute ovality**

expression of the out-of-roundness of a rod-like test piece, which is obtained from the arithmetic difference between the maximum and minimum diameters obtained from  $n$  individual readings

## 3.8

**relative ovality**

ratio of the absolute ovality and the diameter, expressed as a percentage

## 3.9

**relative roundness**

100 minus relative ovality

Note 1 to entry: Caution should be exercised in interpreting maximum diameters, absolute ovality, relative ovality and relative roundness as these can be affected by the quality of the gum line (raised laps) or other product defects, generating erroneous individual readings.

## 4 Principle

## iTeh STANDARD PREVIEW

(standards.iteh.ai)

The principle of measurement of the mean diameter of a shape having a convex cross section follows the generalization of 'Barbier's Theorem', which states that the mean diameter of a section is equal to the arithmetic mean of the apparent (or projected) diameters of the section as it is rotated at equiangular intervals in the field of view. It is required that the section is rotated by an integer multiple of  $180^\circ$ .

NOTE The principle is demonstrated in [Annex B.1](#).

## 5 Apparatus

5.1 **Sample conditioning enclosure**, to be capable of maintaining the conditions given in ISO 3402.

5.2 **Optical measuring apparatus**, to consist of the following.

5.2.1 **Optical measuring instrument**

This must have an uncertainty of no more than 0,01 mm and be suitable for the determination of the diameter of rod-like test pieces with a nearly circular cross section. A schematic diagram of such an instrument is presented in [Figure 1](#) and three different implementations are described in [Annex D](#).

The scanning rate of the instrument shall be such that no eccentric motion of the test piece parallel to the longitudinal axis, within the measurement area, shall affect the accuracy of the measurement of mean diameter.

The ratio between the scanning rate of the apparatus and the rotational speed of the test piece shall be constant and high enough to ensure that the measured diameter, as well as the minimum and maximum values, shall be determined with sufficient accuracy, despite the possible ovality of the test piece.

The length of the scan path shall be sufficiently greater than the maximum diameter to be measured to avoid errors due to test piece eccentricity. The test piece shall be scanned a minimum of 32 times during a half-rotation ( $180^\circ$ ) or 64 times during a full ( $360^\circ$ ) rotation.

NOTE The rationale for the required number of scans is presented in [Annex B.2](#).



## 5.2.2 Apparatus or fixture for rotating the test piece or scan path

This shall rotate the test piece within the measurement area or rotate the direction of view around the test piece while maintaining the longitudinal axis of the test piece perpendicular to the measurement area during a full 360° rotation.

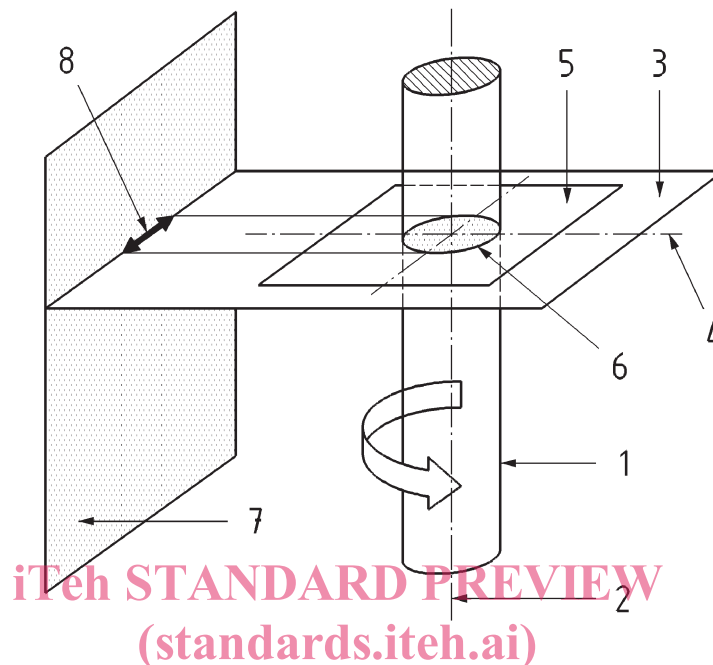

### Key

- 1 test piece
- 2 test piece longitudinal axis and axis of rotation
- 3 plane of the measurement
- 4 measurement centreline
- 5 measurement area
- 6 test piece cross section
- 7 projection plane
- 8 apparent diameter (orthogonal projection or image) of the test piece cross section

**Figure 1 — Diagram of a generic non-contact optical gauging system**

## 6 Sampling

Take a statistically representative sample of the population of test pieces to be characterized.

Samples shall be free of obvious visible defects which may affect the measurement.

## 7 Procedure

### 7.1 Preparation of test pieces

Condition the test pieces, prior to measurement, in a conditioning enclosure in accordance with ISO 3402.

Select at random, from the sample taken in accordance with [Clause 6](#), the number of test pieces required for the test.

**ISO 2971:2013(E)**

The time required for the curing of filter rods and the duration of conditioning for both filter rods and cigarettes are not specified in this International Standard and are to be determined by practical experience. They shall be reported in the test report together with the results.

**7.2 Adjustment and calibration**

Working standards are routinely used to adjust calibrate or check the calibration of the measurement system. Calibration shall be performed in accordance with the manufacturer's instructions.

NOTE The essential properties of calibration standards are given in [Annex A](#).

**7.3 Measurement**

In accordance with the manufacturer's instructions, position the test piece within the measurement area, as close as possible to the centre of the measurement area.

The test piece, or the measuring apparatus, shall be capable of being rotated around the rotation axis such that any eccentric motion of the test piece, relative to the plane of the measurement, remains in parallel with the plane of the measurement and perpendicular to the longitudinal axis of the test piece.

Adjust the instrument and/or feeding and rotational apparatus for the plane of the measurement to measure the required section of the test piece.

Operate the apparatus in accordance with the manufacturer's instructions and accurately record the mean, minimum and maximum diameters.

At least 10 test pieces from one sample shall be used to determine the mean value of the diameter for the sample.

NOTE 1 In practice, laboratories often take a different number of measurements depending on the application of the measurement.

NOTE 2 Possible sources of error in measurement of diameter are given in [Annex C](#).

**8 Expression of results**

The value of the sample mean diameter shall be the mean value of the individual measurements. See [7.3](#).

The results shall be expressed as follows:

- a) diameter, the arithmetic average of at least 64 individual scans per full revolution or 32 scans per half revolution, is expressed in millimetres to the nearest 0,01 mm ;
- b) sample mean diameter, the average of  $x$  diameter measurements ( $x$  is normally 10 but may vary; see note 1 in 7.3) is expressed in millimetres to the nearest 0,001 mm ;
- c) sample maximum diameter, the maximum diameter obtained from a sample of  $x$  test pieces, is expressed in millimetres to the nearest 0,01 mm ;
- d) sample minimum diameter, the minimum diameter obtained from a sample of  $x$  test pieces, is expressed in millimetres to the nearest 0,01 mm ;
- e) absolute ovality is expressed in millimetres to the nearest 0,01 mm ;
- f) relative ovality is expressed as a percentage to the nearest 0,1 % ;
- g) relative roundness is expressed as a percentage to the nearest 0,1 %.

## 9 Repeatability and reproducibility

An international collaborative study involving 14 laboratories was conducted according to ISO 5725-2:1994 in 2009 on matched samples of both filter rods and cigarettes covering a range of approximately 5 mm to 9 mm diameter.

Each measured sample was drawn randomly from a population of typically 3000 rods that, as far as was possible, represented a consistent production process. Three samples of 10 rods, plus spares, were distributed to each participant. Each sample of 10 rods was measured once only. The measurement position for the cigarettes was specified to be on the tobacco column. The measurement position for the filters was not specified.

NOTE 1 Specific details of the measurement protocol are given in [Annex E](#).

The study gave the following values (see Table 1) for mean diameter, repeatability standard deviation ( $s_r$ ), reproducibility standard deviation ( $s_R$ ), repeatability limit ( $r$ ) and reproducibility limit ( $R$ ). The values derived from this interlaboratory study may not be applicable to values and matrices other than those given because the samples being used did not cover all available products.

**Table 1 — Summary of results of collaborative study**

Product type	Mean diameter	$s_r$	$s_R$	$r$	$R$	Comment
	mm	mm	mm	mm	mm	
Mono acetate filter rods, nominally circular cross section	5,335	0,0039	0,0157	0,011	0,044	Non porous
	6,026	0,0031	0,0105	0,009	0,029	Non porous
	6,780	0,0055	0,0137	0,015	0,038	Porous
	7,715	0,0035	0,0131	0,010	0,037	Non porous
	8,511	0,0059	0,0110	0,017	0,031	High porosity
White paper cigarettes, nominally circular cross section	5,428	0,0104	0,0205	0,029	0,057	Unpacked
	6,102	0,0072	0,0156	0,020	0,044	Unpacked
	6,826	0,0035	0,0066	0,010	0,018	Packed
	7,828	0,0047	0,0105	0,013	0,029	Unpacked
	8,612	0,0060	0,0111	0,017	0,031	Unpacked

NOTE 2 The comment for filters refers to the porosity of the filter plug wrap papers, which were in the following ranges: Non porous: < 10 CORESTA Units ; Porous: < 10000 CORESTA Units ; High porosity: > 10000 CORESTA Units

## 10 Test report

The test report shall indicate the method used and the results obtained. It shall also mention any operating conditions not specified in this International Standard, or regarded as optional, as well as any circumstances that may have influenced the results. The test report shall include all details required for complete identification of the sample.

Specifically the test report shall contain:

- date of sampling and sampling method;
- identification and full description of the samples tested, stating the properties (nature, size) of samples;
- date of measurement;
- precise and full measuring conditions, particularly those deviating from the specifications of this International Standard, and any events likely to have affected the results;
- test atmosphere and duration of conditioning (see [7.1](#));