**Pipes and fittings made of crosslinked
polyethylene (PE-X) — Estimation of the
degree of crosslinking by determination
of the gel content**

*Tubes et raccords en polyéthylène réticulé (PE-X) — Estimation du
degré de réticulation par le mesurage du taux de gel*

iTeh STANDARD PREVIEW
(standards.iteh.ai)

ISO 10147:2011

<https://standards.iteh.ai/catalog/standards/sist/fa8eb109-f97e-40ea-a276-e729a34e2ef9/iso-10147-2011>



iTeh STANDARD PREVIEW (standards.iteh.ai)

ISO 10147:2011

<https://standards.iteh.ai/catalog/standards/sist/fa8eb109-f97e-40ea-a276-e729a34e2ef9/iso-10147-2011>



COPYRIGHT PROTECTED DOCUMENT

© ISO 2011

All rights reserved. Unless otherwise specified, no part of this publication may be reproduced or utilized in any form or by any means, electronic or mechanical, including photocopying and microfilm, without permission in writing from either ISO at the address below or ISO's member body in the country of the requester.

ISO copyright office
Case postale 56 • CH-1211 Geneva 20
Tel. + 41 22 749 01 11
Fax + 41 22 749 09 47
E-mail copyright@iso.org
Web www.iso.org

Published in Switzerland

Foreword

ISO (the International Organization for Standardization) is a worldwide federation of national standards bodies (ISO member bodies). The work of preparing International Standards is normally carried out through ISO technical committees. Each member body interested in a subject for which a technical committee has been established has the right to be represented on that committee. International organizations, governmental and non-governmental, in liaison with ISO, also take part in the work. ISO collaborates closely with the International Electrotechnical Commission (IEC) on all matters of electrotechnical standardization.

International Standards are drafted in accordance with the rules given in the ISO/IEC Directives, Part 2.

The main task of technical committees is to prepare International Standards. Draft International Standards adopted by the technical committees are circulated to the member bodies for voting. Publication as an International Standard requires approval by at least 75 % of the member bodies casting a vote.

Attention is drawn to the possibility that some of the elements of this document may be the subject of patent rights. ISO shall not be held responsible for identifying any or all such patent rights.

ISO 10147 was prepared by Technical Committee ISO/TC 138, *Plastics pipes, fittings and valves for the transport of fluids*, Subcommittee SC 5, *General properties of pipes, fittings and valves of plastic materials and their accessories — Test methods and basic specifications*.

This third edition cancels and replaces the second edition (ISO 10147:2004), which has been technically revised. It also incorporates the Amendment ISO 10147:2004/Amd.1:2008.

iTeh STANDARD PREVIEW (standards.iteh.ai)

[ISO 10147:2011](https://standards.iteh.ai/catalog/standards/sist/fa8eb109-f97e-40ea-a276-e729a34e2ef9/iso-10147-2011)

<https://standards.iteh.ai/catalog/standards/sist/fa8eb109-f97e-40ea-a276-e729a34e2ef9/iso-10147-2011>

iTeh STANDARD PREVIEW
(standards.iteh.ai)

ISO 10147:2011

<https://standards.iteh.ai/catalog/standards/sist/fa8eb109-f97e-40ea-a276-e729a34e2ef9/iso-10147-2011>

Pipes and fittings made of crosslinked polyethylene (PE-X) — Estimation of the degree of crosslinking by determination of the gel content

1 Scope

This International Standard specifies a method for the assessment of the degree of crosslinking in crosslinked polyethylene (PE-X) pipes and fittings by determination of the gel content by solvent extraction.

2 Principle

The mass of a test piece taken from a pipe or a fitting is measured before and after immersion of the test piece in a solvent for a specified period of time. The degree of crosslinking is expressed as the percentage by mass of the insoluble material.

For the minimum applicable values for the degree of crosslinking refer to the product or system standards.

3 Solvent

3.1 Xylene, an isomeric mixture with a purity ≥ 98 % volume fraction and a boiling range of 137 °C to 144 °C, to which a 1 % volume fraction of antioxidant has been added.

The antioxidant may be either 2,2-methylene-bis(4-methyl-6-tert-butylphenol) or antioxidants based on 3-(3,5-di-tert-butyl-4-hydroxyphenyl) propionate or a combination of these.

WARNING — Xylene is a harmful and inflammable solvent that can be absorbed through the skin and, as such, should be handled carefully. Attention is drawn to any relevant regulations and associated exposure limits. Use only in a ventilated hood. Check the effectiveness of the hood before starting the test. Do not inhale the vapour. The appropriate safety equipment should be worn. Excessive inhalation of the vapour may cause dizziness, headache or both. In the event of excessive vapour inhalation, seek fresh, clean air.

4 Apparatus

The following apparatus is required in order to carry out the test.

- 4.1 Reflux condenser**, of the general type shown in Figure 1.
- 4.2 Round-bottomed flask**, of at least 500 ml capacity.
- 4.3 Heating mantle**, to fit the flask (4.2), and with sufficient heating capacity to boil xylene (boiling range: 137 °C to 144 °C).
- 4.4 Cage**, with lid, large enough to contain a test piece (see Clause 5).

The cage shall be made of wire cloth or mesh, of aluminium or stainless steel, with a pore size of (125 ± 25) μm and sufficient to retain the sample. The wire cloth or mesh shall be free of grease, oil or other contaminants soluble in xylene. If not, it shall be washed with acetone and dried before use.

- 4.5 Lathe with automatic feed**, for machining out test pieces, or **microtome** or **other suitable cutting tool**.

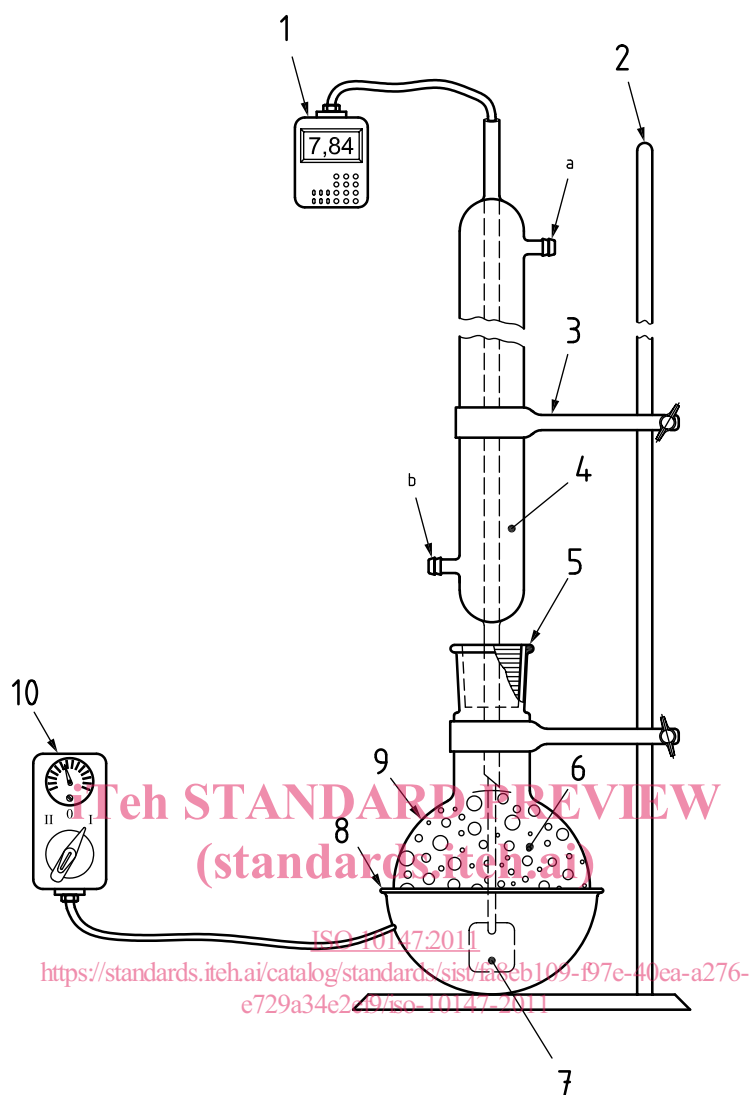

Key

- 1 identification tag and fine wire attached to cage
 - 2 stand
 - 3 ring clamp
 - 4 reflux condenser
 - 5 ground-glass joint or cork
 - 6 xylene
 - 7 wire cage enclosing test piece
 - 8 heating mantle
 - 9 wide-necked round-bottomed flask
 - 10 variable transformer
- a Water out.
b Water in.

Figure 1 — Extraction apparatus

4.6 Vacuum oven or forced-ventilation oven, capable of maintaining the specified conditions (see 6.6).

4.7 Balance, capable of weighing the cage, with or without a test piece, to an accuracy of 1 mg.

5 Preparation of test pieces

The test pieces are prepared in accordance with the following instructions.

Any protective layer on the pipe or test sample shall be removed prior to preparation of test pieces.

Unless otherwise specified in the referring standard, at least two test pieces shall be prepared.

Each test piece shall comprise a slice or shaving having a thickness of $(0,2 \pm 0,02)$ mm, taken from a cross-section of the pipe or fitting to include the full wall thickness round at least one circumference unless specified otherwise by the referring standard. The mass of the test piece shall be $\geq 0,2$ g.

The degree of crosslinking can vary through the wall thickness of a pipe or fitting and therefore, for surface or midwall measurements, test pieces shall be machined accordingly.

It is recommended that a lathe be used to machine test pieces from pipe. Alternatively, a microtome or other suitable cutting tool can be used to obtain the test pieces from fittings.

6 Procedure

6.1 Weigh a clean, dry cage including the lid (see 4.4), to an accuracy of 1 mg (mass m_1).

6.2 Place a test piece in the cage, close the lid and weigh the cage and test piece together to an accuracy of 1 mg (mass m_2).

6.3 Place the cage and test piece in the flask (4.2) and ensure that there is sufficient xylene solvent to maintain total immersion and to provide a ratio by mass of solvent to test piece of at least 200:1.

The solvent can be re-used after distillation with the addition of a further 1 % volume fraction of antioxidant (3.1). In case of dispute, use a new or freshly distilled solution.

6.4 Boil the solvent vigorously to ensure good agitation for $8 \text{ h} \pm 30 \text{ min}$.

6.5 Carefully remove the cage and the residue of the test piece from the solution after the time specified in 6.4.

CAUTION — Take care when removing the cage from the boiling solution (see 3.1).

6.6 Complete the drying of the residue, or cage, lid and residue, by placing them for at least 3 h in:

- a) either a vacuum oven (see 4.6), kept at $(90 \pm 2)^\circ\text{C}$ under a vacuum (negative pressure) of at least 0,85 bar (85 kPa), i.e. approximately 0,15 bar absolute pressure or less; or
- b) a forced-ventilation oven (see 4.6), with an adequate extraction facility, kept at $(140 \pm 2)^\circ\text{C}$.

6.7 Allow to cool to ambient temperature and weigh the residue (mass m_4) or the cage, lid and residue (mass m_3) to an accuracy of 1 mg.

7 Calculation and expression of results

Calculate the degree of crosslinking, G , of the material in the individual test pieces as the percentage by mass of the insoluble material, using one of the following equations as appropriate:

when only the residue was weighed:

$$G = \frac{m_4}{m_2 - m_1} \times 100$$

when the cage, lid and residue were weighed:

$$G = \frac{m_3 - m_1}{m_2 - m_1} \times 100$$

where

- m_1 is the mass of the cage and lid, in milligrams;
- m_2 is the mass of the original test piece, the cage and the lid, in milligrams;
- m_3 is the mass of the residue, cage and lid, in milligrams;
- m_4 is the mass of the residue, in milligrams.

Express the result to the nearest whole number.

The mass of any filler present in the material shall be taken into account.

The average degree of crosslinking, G_a , can be calculated from the individual results of a number of samples.

iTeh STANDARD PREVIEW
(standards.iteh.ai)

8 Test report

The test report shall include the following information:

- a) a reference to this International Standard, i.e. ISO 10147, and, if applicable, to the standards making reference to this one;
- b) all details necessary for the identification of the test piece;
- c) the degree of crosslinking, G , for the individual test pieces and the average, G_a , stating the number of samples tested;
- d) details of any variation in the specified procedure and of any abnormal behaviour observed during the test;
- e) the date of the test.

iTeh STANDARD PREVIEW
(standards.iteh.ai)

ISO 10147:2011

<https://standards.iteh.ai/catalog/standards/sist/fa8eb109-f97e-40ea-a276-e729a34e2ef9/iso-10147-2011>