



# SLOVENSKI STANDARD

## SIST ES 202 740 V1.8.1:2020

01-julij-2020

---

**Kakovost prenosa govora in večpredstavnih vsebin (STQ) - Prenosne zahteve za širokopasovne zvočniške in prostoročne terminale VoIP glede na kakovost storitev (QoS), kot jo dojema uporabnik**

Speech and multimedia Transmission Quality (STQ) - Transmission requirements for wideband VoIP loudspeaking and handsfree terminals from a QoS perspective as perceived by the user

**iTeh STANDARD PREVIEW**  
**(standards.iteh.ai)**

[SIST ES 202 740 V1.8.1:2020](https://standards.iteh.ai/catalog/standards/sist/4f0a149a-01e4-4323-be24-fef045ca79c0/sist-es-202-740-v1-8-1-2020)

[https://standards.iteh.ai/catalog/standards/sist/4f0a149a-01e4-4323-be24-](https://standards.iteh.ai/catalog/standards/sist/4f0a149a-01e4-4323-be24-fef045ca79c0/sist-es-202-740-v1-8-1-2020)

[fe045ca79c0/sist-es-202-740-v1-8-1-2020](https://standards.iteh.ai/catalog/standards/sist/4f0a149a-01e4-4323-be24-fef045ca79c0/sist-es-202-740-v1-8-1-2020)

**Ta slovenski standard je istoveten z: ETSI ES 202 740 V1.8.1 (2020-05)**

---

**ICS:**

33.050.01	Telekomunikacijska terminalska oprema na splošno	Telecommunication terminal equipment in general
-----------	--	---

**SIST ES 202 740 V1.8.1:2020**

**en**

**iTeh STANDARD PREVIEW**  
**(standards.iteh.ai)**

[SIST ES 202 740 V1.8.1:2020](https://standards.iteh.ai/catalog/standards/sist/4f0a149a-01e4-4323-be24-fef045ca79c0/sist-es-202-740-v1-8-1-2020)

<https://standards.iteh.ai/catalog/standards/sist/4f0a149a-01e4-4323-be24-fef045ca79c0/sist-es-202-740-v1-8-1-2020>

# ETSI ES 202 740 V1.8.1 (2020-05)



**Speech and multimedia Transmission Quality (STQ);  
Transmission requirements for wideband  
VoIP loudspeaking and handsfree terminals  
from a QoS perspective as perceived by the user**

<https://standards.iteh.ai/catalog/standards/sist/4f0a149a-01e4-4323-be24-fef045ca79c0/sist-es-202-740-v1-8-1-2020>

---

**Reference**

RES/STQ-277

---

**Keywords**handsfree, loudspeaking, quality, speech,  
terminal, VoIP, wideband**ETSI**650 Route des Lucioles  
F-06921 Sophia Antipolis Cedex - FRANCE

Tel.: +33 4 92 94 42 00 Fax: +33 4 93 65 47 16

Siret N° 348 623 562 00017 - NAF 742 C  
Association à but non lucratif enregistrée à la  
Sous-Préfecture de Grasse (06) N° 7803/88

**iTeh STANDARD PREVIEW**  
**(standards.iteh.ai)**

---

**Important notice**

<https://standards.iteh.ai/catalog/standards/sist/4f0a149a-01e4-4323-bc24-1a453a9c158e/sist-2020-140-11-1-2020>  
The present document can be downloaded from:  
<http://www.etsi.org/standards-search>

The present document may be made available in electronic versions and/or in print. The content of any electronic and/or print versions of the present document shall not be modified without the prior written authorization of ETSI. In case of any existing or perceived difference in contents between such versions and/or in print, the prevailing version of an ETSI deliverable is the one made publicly available in PDF format at [www.etsi.org/deliver](http://www.etsi.org/deliver).

Users of the present document should be aware that the document may be subject to revision or change of status. Information on the current status of this and other ETSI documents is available at <https://portal.etsi.org/TB/ETSIDeliverableStatus.aspx>

If you find errors in the present document, please send your comment to one of the following services:  
<https://portal.etsi.org/People/CommiteeSupportStaff.aspx>

---

**Copyright Notification**

No part may be reproduced or utilized in any form or by any means, electronic or mechanical, including photocopying and microfilm except as authorized by written permission of ETSI.

The content of the PDF version shall not be modified without the written authorization of ETSI.

The copyright and the foregoing restriction extend to reproduction in all media.

© ETSI 2020.

All rights reserved.

**DECT™**, **PLUGTESTS™**, **UMTS™** and the ETSI logo are trademarks of ETSI registered for the benefit of its Members.

**3GPP™** and **LTE™** are trademarks of ETSI registered for the benefit of its Members and of the 3GPP Organizational Partners.

**oneM2M™** logo is a trademark of ETSI registered for the benefit of its Members and of the oneM2M Partners.

**GSM®** and the GSM logo are trademarks registered and owned by the GSM Association.

# Contents

Intellectual Property Rights .....	5
Foreword.....	5
Modal verbs terminology.....	5
Introduction .....	5
1 Scope .....	6
2 References .....	6
2.1 Normative references .....	6
2.2 Informative references.....	7
3 Definition of terms, symbols and abbreviations.....	8
3.1 Terms.....	8
3.2 Symbols.....	9
3.3 Abbreviations .....	9
4 General considerations .....	10
4.1 Coding algorithm.....	10
4.2 End-to-end considerations .....	10
5 Test equipment .....	11
5.1 IP half channel measurement adaptor.....	11
5.2 Environmental conditions for tests .....	11
5.3 Accuracy of measurements and test signal generation .....	11
5.4 Network impairment simulation.....	12
5.5 Acoustic environment.....	12
5.6 Influence of terminal delay on measurements .....	12
6 Requirements and associated measurement methodologies.....	12
6.1 Notes .....	12
6.2 Test setup.....	13
6.2.1 General.....	13
6.2.2 Setup for terminals.....	13
6.2.2.1 Hands-free measurements .....	13
6.2.2.2 Measurements in loudspeaking mode .....	18
6.2.3 Test signal levels.....	18
6.2.3.1 Send.....	18
6.2.3.2 Receive.....	19
6.2.4 Setup of background noise simulation .....	19
6.2.5 Setup for variable echo path .....	20
6.3 Coding independent parameters .....	20
6.3.1 Send sensitivity/frequency response .....	20
6.3.2 Send Loudness Rating (SLR).....	21
6.3.3 Mic mute.....	22
6.3.4 Send distortion .....	22
6.3.5 Out-of-band signals in send direction .....	23
6.3.6 Send noise .....	23
6.3.7 Terminal Coupling Loss (TCL) .....	24
6.3.8 Stability loss.....	25
6.3.9 Receive frequency response.....	25
6.3.10 Receive Loudness Rating (RLR) .....	27
6.3.11 Receive distortion .....	28
6.3.12 Out-of-band signals in receive direction.....	29
6.3.13 Receive noise .....	29
6.3.14 Double talk performance .....	30
6.3.14.1 General .....	30
6.3.14.2 Attenuation range in send direction during double talk $A_{H,S,dt}$ .....	30
6.3.14.3 Attenuation range in receive direction during double talk $A_{H,R,dt}$ .....	31

6.3.14.4	Detection of echo components during double talk .....	32
6.3.14.5	Minimum activation level and sensitivity of double talk detection.....	33
6.3.15	Switching characteristics .....	34
6.3.15.1	Note.....	34
6.3.15.2	Activation in send direction .....	34
6.3.15.3	Silence suppression and comfort noise generation.....	34
6.3.16	Background noise performance .....	35
6.3.16.1	Performance in send direction in the presence of background noise.....	35
6.3.16.2	Speech quality in the presence of background noise.....	35
6.3.16.3	Quality of background noise transmission (with far end speech).....	36
6.3.17	Quality of echo cancellation .....	37
6.3.17.1	Temporal echo effects .....	37
6.3.17.2	Spectral echo attenuation .....	37
6.3.17.3	Occurrence of artefacts .....	38
6.3.17.4	Variable echo path.....	38
6.3.18	Variant impairments .....	38
6.3.18.1	Clock accuracy send.....	38
6.3.18.2	Clock accuracy receive .....	39
6.3.18.3	Send packet delay variation.....	39
6.3.19	Send and receive delay - round trip delay.....	40
6.4	Codec specific requirements.....	41
6.4.1	Objective listening speech quality MOS-LQO in send direction.....	41
6.4.2	Objective listening speech quality MOS-LQO in receive direction.....	42
6.4.3	Quality of jitter buffer adjustment .....	44
<b>Annex A (informative):</b>	<b>Processing delays in VoIP terminals .....</b>	<b>46</b>
<b>Annex B (informative):</b>	<b>Bibliography.....</b>	<b>49</b>
History .....		50

[SIST ES 202 740 V1.8.1:2020](https://standards.iteh.ai/catalog/standards/sist/4f0a149a-01e4-4323-bc24-fef045ca79c0/sist-es-202-740-v1-8-1-2020)  
<https://standards.iteh.ai/catalog/standards/sist/4f0a149a-01e4-4323-bc24-fef045ca79c0/sist-es-202-740-v1-8-1-2020>

---

## Intellectual Property Rights

### Essential patents

IPRs essential or potentially essential to normative deliverables may have been declared to ETSI. The information pertaining to these essential IPRs, if any, is publicly available for **ETSI members and non-members**, and can be found in ETSI SR 000 314: "*Intellectual Property Rights (IPRs); Essential, or potentially Essential, IPRs notified to ETSI in respect of ETSI standards*", which is available from the ETSI Secretariat. Latest updates are available on the ETSI Web server (<https://ipr.etsi.org/>).

Pursuant to the ETSI IPR Policy, no investigation, including IPR searches, has been carried out by ETSI. No guarantee can be given as to the existence of other IPRs not referenced in ETSI SR 000 314 (or the updates on the ETSI Web server) which are, or may be, or may become, essential to the present document.

### Trademarks

The present document may include trademarks and/or tradenames which are asserted and/or registered by their owners. ETSI claims no ownership of these except for any which are indicated as being the property of ETSI, and conveys no right to use or reproduce any trademark and/or tradename. Mention of those trademarks in the present document does not constitute an endorsement by ETSI of products, services or organizations associated with those trademarks.

---

## Foreword

This ETSI Standard (ES) has been produced by ETSI Technical Committee Speech and Multimedia Transmission Quality (STQ).

---

## Modal verbs terminology

In the present document "**shall**", "**shall not**", "**should**", "**should not**", "**may**", "**need not**", "**will**", "**will not**", "**can**" and "**cannot**" are to be interpreted as described in clause 3.2 of the [ETSI Drafting Rules](https://standards.iteh.ai/catalog/standards/sist/4f0a149a-01e4-4323-be24-1e645ca79c03/sist-es-202-740-v1-8-1-2020) (Verbal forms for the expression of provisions).

"**must**" and "**must not**" are **NOT** allowed in ETSI deliverables except when used in direct citation.

---

## Introduction

Traditionally, analogue and digital telephones were interfacing switched-circuit 64 kbit/s PCM networks. With the fast growth of IP networks, wideband terminals providing higher audio-bandwidth and directly interfacing packet-switched networks (VoIP) are being rapidly introduced. Such IP network edge devices may include gateways, specifically designed IP phones, soft phones or other devices connected to the IP based networks and providing telephony service. Due to the unique characteristics of the IP networks including packet loss, delay, etc., new performance specification, as well as appropriate measurement methods, will have to be developed. Terminals are getting increasingly complex.

The advanced signal processing of terminals is targeted to speech signals. Therefore, wherever possible speech signals are used for testing in order to achieve mostly realistic test conditions and meaningful results.

The present document provides speech transmission performance requirements for wideband VoIP loudspeaking and hands-free terminals.

NOTE: Requirement limits are given in tables, the associated curve when provided is given for illustration.

---

# 1 Scope

The present document provides speech transmission performance requirements for 8 kHz wideband VoIP loudspeaking and hands-free terminals; it addresses all types of IP based terminals, including wireless, softphones and group audio terminals. DECT terminals are covered in ETSI EN 300 175-8 [i.6] and ETSI EN 300 176-2 [i.7].

In contrast to other standards which define minimum performance requirements it is the intention of the present document to specify terminal equipment requirements which enable manufacturers and service providers to enable good quality end-to-end speech performance as perceived by the user.

In addition to basic testing procedures, the present document describes advanced testing procedures taking into account further quality parameters as perceived by the user.

NOTE: The present document does not concern headset terminals.

---

# 2 References

## 2.1 Normative references

References are either specific (identified by date of publication and/or edition number or version number) or non-specific. For specific references, only the cited version applies. For non-specific references, the latest version of the referenced document (including any amendments) applies.

Referenced documents which are not found to be publicly available in the expected location might be found at <https://docbox.etsi.org/Reference>.

NOTE: While any hyperlinks included in this clause were valid at the time of publication, ETSI cannot guarantee their long term validity.

The following referenced documents are necessary for the application of the present document.

- [1] ETSI I-ETS 300 245-6: "Integrated Services Digital Network (ISDN); Technical characteristics of telephony terminals; Part 6: Wideband (7 kHz), loudspeaking and hands free telephony".
- [2] Recommendation ITU-T G.108: "Application of the E-model: A planning guide".
- [3] Recommendation ITU-T G.109: "Definition of categories of speech transmission quality".
- [4] Recommendation ITU-T G.722: "7 kHz audio-coding within 64 kbit/s".
- [5] Recommendation ITU-T G.722.1: "Low-complexity coding at 24 and 32 kbit/s for hands-free operation in systems with low frame loss".
- [6] Recommendation ITU-T G.722.2: "Wideband coding of speech at around 16 kbit/s using Adaptive Multi-Rate Wideband (AMR-WB)".
- [7] Recommendation ITU-T G.729.1: "G.729 based embedded variable bit-rate coder: An 8-32 kbit/s scalable wideband coder bitstream interoperable with G.729".
- [8] Recommendation ITU-T P.56: "Objective measurement of active speech level".
- [9] Recommendation ITU-T P.58: "Head and torso simulator for telephonometry".
- [10] Recommendation ITU-T P.79: "Calculation of loudness ratings for telephone sets".
- [11] Recommendation ITU-T P.310: "Transmission characteristics for narrow-band digital handset and headset telephones".
- [12] Recommendation ITU-T P.340: "Transmission characteristics and speech quality parameters of hands-free terminals".



- [13] Recommendation ITU-T P.341: "Transmission characteristics for wideband digital loudspeaking and hands-free telephony terminals".
- [14] Recommendation ITU-T P.501: "Test signals for use in telephony".
- [15] Recommendation ITU-T P.502: "Objective test methods for speech communication systems using complex test signals".
- [16] Recommendation ITU-T P.581: "Use of head and torso simulator for hands-free and handset terminal testing".
- [17] IEC 61260-1: "Electroacoustics - Octave-band and fractional-octave-band filters - Part 1: Specifications".
- [18] Recommendation ITU-T P.800.1: "Mean Opinion Score (MOS) terminology".
- [19] ETSI TS 103 224: "Speech and multimedia Transmission Quality (STQ); A sound field reproduction method for terminal testing including a background noise database".
- [20] Recommendation ITU-T P.863.1: "Application guide for Recommendation ITU-T P.863".
- [21] Recommendation ITU-T P.863: "Perceptual objective listening quality prediction".
- [22] ETSI ES 202 737: "Speech and multimedia Transmission Quality (STQ); Transmission requirements for narrowband VoIP terminals (handset and headset) from a QoS perspective as perceived by the user".
- [23] Recommendation ITU-T P.1010: "Fundamental voice transmission objectives for VoIP terminals and gateways".
- [24] IETF RFC 3550: "RTP: A Transport Protocol for Real-Time Applications".
- [25] TIA-920.130: "Telecommunications Communications Products Transmission Requirements for Digital Interface Communications Devices with Headsets".
- [26] Recommendation ITU-T G.122: "Influence of national systems on stability and talker echo in international connections".
- [27] IETF RFC 5481: "Packet Delay Variation Applicability Statement".
- [28] Recommendation ITU-T G.711: "Pulse code modulation (PCM) of voice frequencies".
- [29] Recommendation ITU-T G.729: "Coding of speech at 8 kbit/s using conjugate-structure algebraic-code-excited linear prediction (CS-ACELP)".
- [30] Recommendation ITU-T G.723.1: "Dual rate speech coder for multimedia communications transmitting at 5.3 and 6.3 kbit/s".

## 2.2 Informative references

References are either specific (identified by date of publication and/or edition number or version number) or non-specific. For specific references, only the cited version applies. For non-specific references, the latest version of the referenced document (including any amendments) applies.

NOTE: While any hyperlinks included in this clause were valid at the time of publication, ETSI cannot guarantee their long term validity.

The following referenced documents are not necessary for the application of the present document but they assist the user with regard to a particular subject area.

- [i.1] ETSI EG 202 425: "Speech Processing, Transmission and Quality Aspects (STQ); Definition and implementation of VoIP reference point".

- [i.2] ETSI EG 202 396-3: "Speech and multimedia Transmission Quality (STQ); Speech Quality performance in the presence of background noise; Part 3: Background noise transmission - Objective test methods".
- [i.3] Netem™.
- NOTE: Information available at <https://wiki.linuxfoundation.org/networking/netem>.
- [i.4] ETSI EG 201 377-1: "Speech and multimedia Transmission Quality (STQ); Specification and measurement of speech transmission quality; Part 1: Introduction to objective comparison measurement methods for one-way speech quality across networks".
- [i.5] IETF RFC 4737: "Packet Reordering Metrics".
- [i.6] ETSI EN 300 175-8: "Digital Enhanced Cordless Telecommunications (DECT); Common Interface (CI); Part 8: Speech and audio coding and transmission".
- [i.7] ETSI EN 300 176-2: "Digital Enhanced Cordless Telecommunications (DECT); Test specification; Part 2: Audio and speech".

## 3 Definition of terms, symbols and abbreviations

### 3.1 Terms

For the purposes of the present document, the following terms apply:

**artificial ear:** device for the calibration of earphones incorporating an acoustic coupler and a calibrated microphone for the measurement of the sound pressure and having an overall acoustic impedance similar to that of the median adult human ear over a given frequency band

**codec:** combination of an analogue-to-digital encoder and a digital-to-analogue decoder operating in opposite directions of transmission in the same equipment

**ear-Drum Reference Point (DRP):** point located at the end of the ear canal, corresponding to the ear-drum position

**freefield equalization:** artificial head is equalized in such a way that for frontal sound incidence in anechoic conditions the frequency response of the artificial head is flat

**freefield reference point:** point located in the free sound field, at least in 1,5 m distance from a sound source radiating in free air

NOTE: In case of a head and torso simulator (HATS) in the centre of the artificial head with no artificial head present.

**group-audio terminal:** handsfree terminal primarily designed for use by several users which will not be equipped with a handset

**handsfree telephony terminal:** telephony terminal using a loudspeaker associated with an amplifier as a telephone receiver and which can be used without a handset

**HATS Hands-Free Reference Point (HATS HFRP):** reference point "n" from Recommendation ITU-T P.58 [9] "n" is one of the points numbered from 11 to 17 and defined in table 6a of Recommendation ITU-T P.58 [9], (coordinates of far field front point)

NOTE: The HATS HFRP depends on the location(s) of the microphones of the terminal under test: the appropriate axis lip-ring/HATS HFRP is to be as close as possible to the axis lip-ring/HFT microphone under test.

**Head And Torso Simulator (HATS) for telephonometry:** manikin extending downward from the top of the head to the waist, designed to simulate the sound pick-up characteristics and the acoustic diffraction produced by a median human adult and to reproduce the acoustic field generated by the human mouth

**loudspeaking function:** function of a handset telephone using a loudspeaker associated with an amplifier as a telephone receiver

**Mouth Reference Point (MRP):** point located on axis and 25 mm in front of the lip plane of a mouth simulator

**nominal setting of the volume control:** setting which is closest to the nominal RLR

**reordering:** packet order changes during transfer over the network [i.5], packets arrive out of order at the receiver (i.e. RTP packets)

**softphone:** speech communication system based upon a computer

## 3.2 Symbols

Void.

## 3.3 Abbreviations

For the purposes of the present document, the following abbreviations apply:

AM-FM	Amplitude Modulation - Frequency Modulation
AMR-WB	Adaptative Multi Rate - Wideband
CS	Composite Source
CSS	Composite Source Signal
DRP	ear-Drum Reference Point
DUT	Devise Under Test
EC	Echo Canceller
EL	Echo Loss
ERP	Ear Reference Point
FFT	Fast Fourrier Transform
G-MOS-LQOw	Overall transmission quality wideband
GSM	Global System for Mobile communications
HATS	Head And Torso Simulator
HFRP	Hands Free Reference Point
HFT	Hands Free Terminal
IEC	International Electrotechnical Commission
IP	Internet Protocol
IPDV	IP Packet Delay Variation
ITU-T	International Telecommunication Union -Telecommunication standardization sector
LE	Earphone coupling Loss
MOS	Mean Opinion Score
MOS-LQOy	Mean Opinion Score - Listening Quality Objective

NOTE: y being N for narrowband, M for mixed, S for super-wideband and F for fullband. See Recommendation ITU-T P.800.1 [18].

MRP	Mouth Reference Point
N-MOS-LQOw	Transmission quality of the background noise wideband
NLP	Non Linear Processor
PBX	Private Branch eXchange
PC	Personal Computer
PCM	Pulse Code Modulation
PDA	Personal Digital Assistant
PMRP	Sound Pressure at the Mouth Reference Point
PN	Pseudo Noise
POI	Point Of Interconnection
QoS	Quality of Service
RLR	Receive Loudness Rating
RMS	Root Mean Square
RTP	Real-Time Transport Protocol
S-MOS-LQOw	Transmission quality of the speech wideband

SLR	Send Loudness Rating
TCL	Terminal Coupling Loss
TDM	Time Division Multiplex
TELR	Talker Echo Loudness Rating
TOSQA	Telecommunications Objective Speech Quality Assessment
VAD	Voice Activity Detection
VoIP	Voice over Internet Protocol

---

## 4 General considerations

### 4.1 Coding algorithm

The coding algorithm assumed in the present document is according to Recommendation ITU-T G.722 [4]. VoIP terminals may support other coding algorithms.

NOTE: Associated Packet Loss Concealment, e.g. as defined in Recommendation ITU-T G.722 [4], appendixes 3 and 4, should be used.

### 4.2 End-to-end considerations

In order to achieve a desired end-to-end speech transmission performance (mouth-to-ear) it is recommended that general rules of transmission planning tasks are carried out with the E-model taking into account that E-model does not directly address handsfree or loudspeaking terminals; this includes the a-priori determination of the desired category of speech transmission quality as defined in Recommendation ITU-T G.109 [3].

While, in general, the transmission characteristics of single circuit-oriented network elements, such as switches or terminals can be assumed to have a single input value for the planning tasks of Recommendation ITU-T G.108 [2], this approach is not applicable in packet based systems and thus there is a need for the transmission planner's specific attention.

In particular the decision as to which delay measured according to the present document should be acceptable or representative for the specific configuration is the responsibility of the individual transmission planner.

Recommendation ITU-T G.108 [2] with its amendments provides further guidance on this important issue.

The following optimum terminal parameters from a user's perspective need to be considered:

- Minimized delay in send and receive direction.
- Optimum loudness rating (RLR, SLR).
- Compensation for network delay variation.
- Packet loss recovery performance.
- Maximized terminal coupling loss.
- Some more basic (ETSI I-ETS 300 245-6 [1]) parameters are applicable, if Recommendation ITU-T G.722 [4] is used.

## 5 Test equipment

### 5.1 IP half channel measurement adaptor

The IP half channel measurement adaptor is described in ETSI EG 202 425 [i.1].

### 5.2 Environmental conditions for tests

The following conditions shall apply for the testing environment:

- a) ambient temperature: 15 °C to 35 °C;
- b) relative humidity: 5 % to 85 %;
- c) air pressure: 86 kPa to 106 kPa (860 mbar to 1 060 mbar).

### 5.3 Accuracy of measurements and test signal generation

Unless specified otherwise, the accuracy of measurements made by test equipment shall be equal to or better than:

**Table 1: Measurement accuracy**

Item	Accuracy
Electrical signal level	$\pm 0,2$ dB for levels $\geq -50$ dBV $\pm 0,4$ dB for levels $< -50$ dBV
Sound pressure	$\pm 0,7$ dB
Frequency	$\pm 0,2$ %
Time	$\pm 0,2$ %
Application force	$\pm 2$ %
Measured maximum frequency	20 kHz

NOTE: The measured maximum frequency is due to Recommendation ITU-T P.58 [9] limitations.

Unless specified otherwise, the accuracy of the signals generated by the test equipment shall be better than:

**Table 2: Accuracy of test signal generation**

Quantity	Accuracy
Sound pressure level at Mouth Reference Point (MRP)	$\pm 3$ dB for frequencies from 100 Hz to 200 Hz $\pm 1$ dB for frequencies from 200 Hz to 4 000 Hz $\pm 3$ dB for frequencies from 4 000 Hz to 8 000 Hz
Electrical excitation levels	$\pm 0,4$ dB across the whole frequency range
Frequency generation	$\pm 2$ % (see note)
Time	$\pm 0,2$ %
Specified component values	$\pm 1$ %
NOTE:	This tolerance may be used to avoid measurements at critical frequencies, e.g. those due to sampling operations within the terminal under test.

For terminal equipment which is directly powered from the mains supply, all tests shall be carried out within  $\pm 5$  % of the rated voltage of that supply. If the equipment is powered by other means and those means are not supplied as part of the apparatus, all tests shall be carried out within the power supply limit declared by the supplier. If the power supply is alternate current, the test shall be conducted within  $\pm 4$  % of the rated frequency.

## 5.4 Network impairment simulation

At least one set of requirements is based on the assumption of an error free packet network, and at least one other set of requirements is based on a defined simulated loss of performance of the packet network.

An appropriate network simulator has to be used, for example Netem™ [i.3]. The key points of Netem™ can be summarized as follows:

- Netem™ is part of the networking function of Linux™. With Netem™, there can be generated loss, duplication, delay, jitter and reordering (and the distribution of jitter can be chosen during runtime). Netem™ can be run on a Linux™-PC running as a bridge or a router.
- It is not advised to define specific distortion patterns for testing in standards, because it will be easy to adapt devices to these patterns (as it is already done for test signals). But if a pattern is unknown to a manufacturer, the same pattern can be used by a test lab for different devices and gives comparable results.

NOTE: Netem™ and Linux™ are examples of suitable products available commercially. This information is given for the convenience of users of the present document and does not constitute an endorsement by ETSI of these product(s).

Requirements for the network impairment simulation can be found in annex D of ETSI ES 202 737 [22].

## 5.5 Acoustic environment

Unless stated otherwise measurements shall be conducted under quiet and "anechoic" conditions. Depending on the distance of the transducers from mouth and ear a quiet office room may be sufficient e.g. for handsets where artificial mouth and artificial ear are located close to the acoustical transducers. But this is not applicable for handsfree and loudspeaking terminals.

In cases where real or simulated background noise is used as part of the testing environment, the original background noise shall not be noticeably influenced by the acoustical properties of the room.

In all cases where the performance of acoustic echo cancellers shall be tested, a realistic room, which represents the typical user environment for the terminal shall be used.

In case where an anechoic room is not available the test room has to be an acoustically treated room with few reflections and a low noise level.

Considering this, test laboratory, in the case where its test room does not conform to anechoic conditions as given in Recommendation ITU-T P.341 [13], has to present difference in results for measurements due to its test room.

## 5.6 Influence of terminal delay on measurements

As delay is introduced by the terminal, care shall be taken for all measurements where exact position of the analysis window is required. It shall be checked that the test is performed on the test signal and not on any other signal.

---

# 6 Requirements and associated measurement methodologies

## 6.1 Notes

NOTE 1: In general the test methods as described in the present document apply. If alternative methods exist they may be used if they have been proven to give the same result as the method described in the present document. This will be indicated in the test report.

NOTE 2: Due to time variant nature of IP connection, delay variation may impair the measurement. In such case, the measurement has to be repeated until a valid measurement can be achieved.

## 6.2 Test setup

### 6.2.1 General

In order to use a compatible test system for all types of speech terminals a HATS (Head And Torso Simulator) will be used instead of freefield microphone (for receive measurement) and artificial mouth (for send measurement). HATS is described in Recommendation ITU-T P.58 [9].

The preferred way of testing a terminal is to connect it to a network simulator with exact defined settings and access points. The test sequences are fed in either electrically, using a reference codec or using the direct signal processing approach or acoustically using ITU-T specified devices.

When a coder with variable bit rate is used for testing the terminal parameters, the bit rate recognized giving the best characteristics and/or the ones commonly used should be selected, e.g.:

- Recommendation ITU-T G.722 [4]: 64 kbit/s.
- Recommendation ITU-T G.722.2 [6]: 12,65 kbit/s and/or 23,85 kbit/s.
- Recommendation ITU-T G.729.1 [7]: 32 kbit/s.

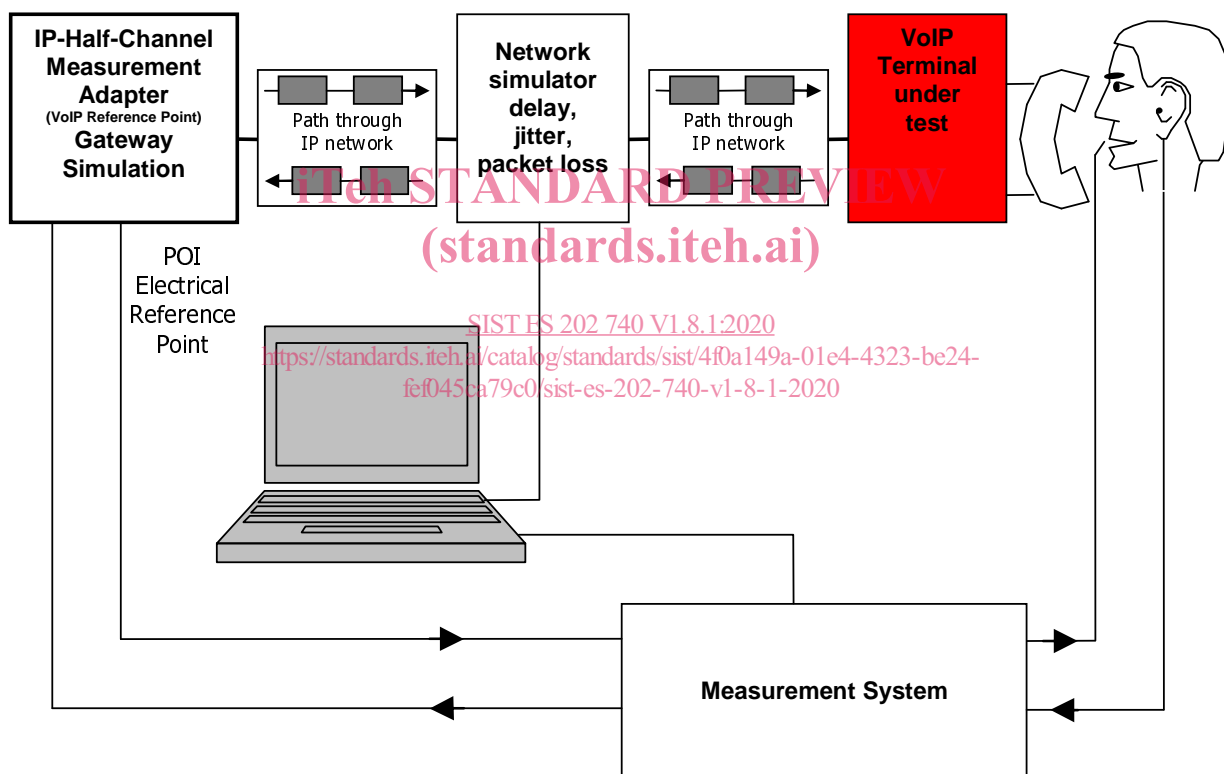

Figure 1: Half channel terminal measurement

### 6.2.2 Setup for terminals

#### 6.2.2.1 Hands-free measurements

The ear used for measurement will be indicated in the test report.

##### Desktop operated hands-free terminal

For HATS test equipment, definition of hands-free terminal and setups for hands-free terminal can be found in Recommendation ITU-T P.581 [16].