**Hydraulic fluid power — Dimensions
and requirements for screw-to-
connect quick-action couplings for
general purpose**

*Transmissions hydrauliques — Dimensions et exigences des raccords
rapides de type à visser pour usage général*

iTeh STANDARD PREVIEW
(standards.iteh.ai)

[ISO 14541:2013](#)

<https://standards.iteh.ai/catalog/standards/sist/8119d1e3-60da-41eb-ad4b-d18d630984a3/iso-14541-2013>



iTeh STANDARD PREVIEW
(standards.iteh.ai)

ISO 14541:2013

<https://standards.iteh.ai/catalog/standards/sist/8119d1e3-60da-41eb-ad4b-d18d630984a3/iso-14541-2013>



COPYRIGHT PROTECTED DOCUMENT

© ISO 2013

All rights reserved. Unless otherwise specified, no part of this publication may be reproduced or utilized otherwise in any form or by any means, electronic or mechanical, including photocopying, or posting on the internet or an intranet, without prior written permission. Permission can be requested from either ISO at the address below or ISO's member body in the country of the requester.

ISO copyright office
Case postale 56 • CH-1211 Geneva 20
Tel. + 41 22 749 01 11
Fax + 41 22 749 09 47
E-mail copyright@iso.org
Web www.iso.org

Published in Switzerland

Contents

	Page
Foreword	iv
Introduction	v
1 Scope	1
2 Normative references	1
3 Terms and definitions	1
4 Dimensional requirements	1
5 Performance requirements	3
6 Assembly instruction	3
7 Designation	4
8 Marking	4
9 Identification statement (reference to this International Standard)	4
Bibliography	5

iTeh STANDARD PREVIEW (standards.iteh.ai)

[ISO 14541:2013](https://standards.iteh.ai/catalog/standards/sist/8119d1e3-60da-41eb-ad4b-d18d630984a3/iso-14541-2013)

<https://standards.iteh.ai/catalog/standards/sist/8119d1e3-60da-41eb-ad4b-d18d630984a3/iso-14541-2013>

Foreword

ISO (the International Organization for Standardization) is a worldwide federation of national standards bodies (ISO member bodies). The work of preparing International Standards is normally carried out through ISO technical committees. Each member body interested in a subject for which a technical committee has been established has the right to be represented on that committee. International organizations, governmental and non-governmental, in liaison with ISO, also take part in the work. ISO collaborates closely with the International Electrotechnical Commission (IEC) on all matters of electrotechnical standardization.

The procedures used to develop this document and those intended for its further maintenance are described in the ISO/IEC Directives, Part 1. In particular the different approval criteria needed for the different types of ISO documents should be noted. This document was drafted in accordance with the editorial rules of the ISO/IEC Directives, Part 2. www.iso.org/directives

Attention is drawn to the possibility that some of the elements of this document may be the subject of patent rights. ISO shall not be held responsible for identifying any or all such patent rights. Details of any patent rights identified during the development of the document will be in the Introduction and/or on the ISO list of patent declarations received. www.iso.org/patents

Any trade name used in this document is information given for the convenience of users and does not constitute an endorsement.

The committee responsible for this document is ISO/TC 131, *Fluid power systems*, Subcommittee SC 4, *Connectors and similar products and components*.

PREVIEW
(standards.iteh.ai)

[ISO 14541:2013](https://standards.iteh.ai/catalog/standards/sist/8119d1e3-60da-41eb-ad4b-d18d630984a3/iso-14541-2013)

<https://standards.iteh.ai/catalog/standards/sist/8119d1e3-60da-41eb-ad4b-d18d630984a3/iso-14541-2013>

Introduction

In hydraulic fluid power systems, power is transmitted and controlled through a liquid under pressure within an enclosed circuit.

Quick-action couplings, including the screw-to-connect type, are used to join or separate fluid conductors either by hand or the use of a tool.

iTeh STANDARD PREVIEW (standards.iteh.ai)

[ISO 14541:2013](https://standards.iteh.ai/catalog/standards/sist/8119d1e3-60da-41eb-ad4b-d18d630984a3/iso-14541-2013)

<https://standards.iteh.ai/catalog/standards/sist/8119d1e3-60da-41eb-ad4b-d18d630984a3/iso-14541-2013>

iTeh STANDARD PREVIEW
(standards.iteh.ai)

ISO 14541:2013

<https://standards.iteh.ai/catalog/standards/sist/8119d1e3-60da-41eb-ad4b-d18d630984a3/iso-14541-2013>

Hydraulic fluid power — Dimensions and requirements for screw-to-connect quick-action couplings for general purpose

1 Scope

This International Standard specifies the dimensional and performance requirements for hydraulic screw-to-connect quick-action couplings for general use.

2 Normative references

The following documents, in whole or in part, are normatively referenced in this document and are indispensable for its application. For dated references, only the edition cited applies. For undated references, the latest edition of the referenced document (including any amendments) applies.

ISO 724, *ISO General-purpose metric screw threads — Basic dimensions*

ISO 965-1, *ISO General-purpose metric screw threads — Tolerances — Part 1: Principles and basic data*

ISO 1302, *Geometrical Product Specifications (GPS) — Indication of surface texture in technical product documentation*

ISO 5598, *Fluid power systems and components — Vocabulary*

ISO 7241-2, *Hydraulic fluid power — Quick-action couplings — Part 2: Test methods*

ISO 14541:2013

3 Terms and definitions

<https://standards.iteh.ai/catalog/standards/sist/8119d1e3-60da-41eb-ad4b-d18d630984a3/iso-14541-2013>

For the purposes of this document, the terms and definitions given in ISO 5598 and the following apply.

3.1

fluid loss

fluid that exits the coupling when it is disconnected

3.2

male half

part of the coupling with rotating sleeve

3.3

residual static pressure

static pressure remaining in the circuit without flow

3.4

sleeve

part that connects with female thread

4 Dimensional requirements

4.1 Couplings shall conform to the dimensions shown in [Figure 1](#) and given in [Table 1](#).

Surface roughness values in micrometres and in accordance with ISO 1302

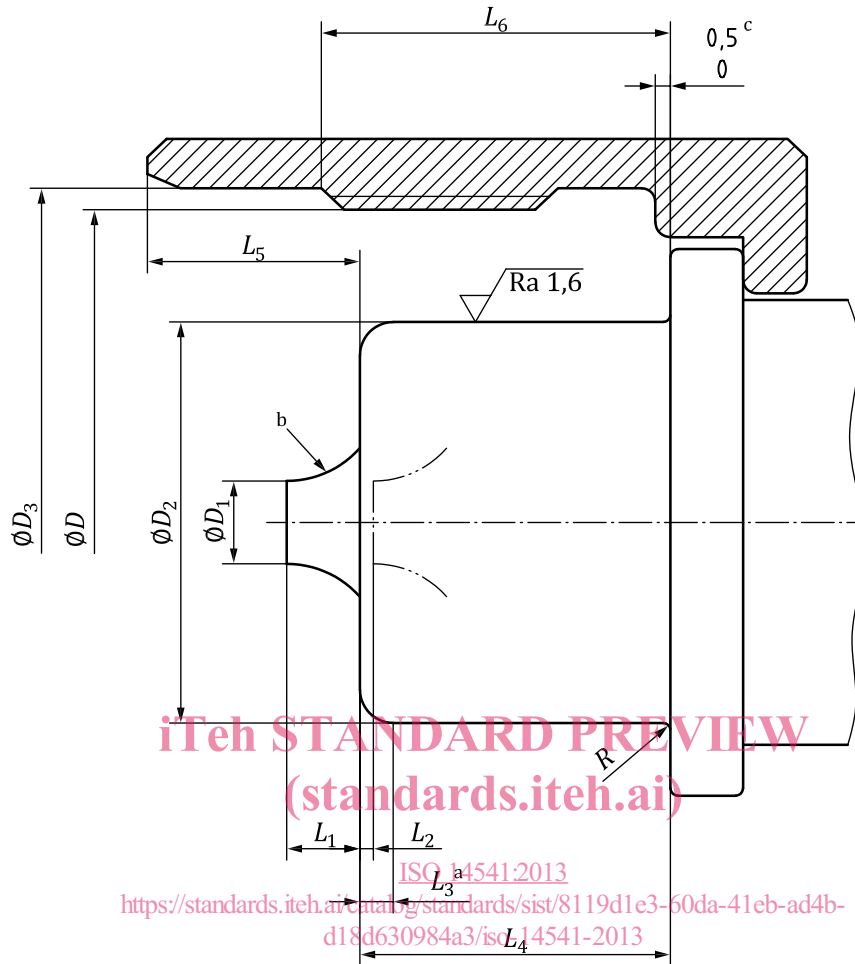

- a Radius or combined radius-chamfer.
- b The valve shape is optional.
- c See 4.4.

Figure 1 — Dimensional requirements

Table 1 — Dimensional requirements

Dimensions in millimetres

Coupling size	D^a	ΦD_1 min	ΦD_2	ΦD_3	L_1 max	L_2 max	L_3	L_4	L_5 min	L_6 $\pm 0,3$	R max
6,3	M24 x 2	2,5	12,85 12,95	24,40 24,50	3,5	0,5	1 1,5	14,65 14,75	11,5	15,2	0,5
10	M28 x 2	3,0	17,35 17,45	28,45 28,55	3,8	0,5	1 2	14,95 15,05	12,1	14,1	0,5
12,5	M36 x 2	4,5	21,90 22,00	36,50 36,70	4,5	0,5	1,5 2,5	16,95 17,05	11,3	16,3	0,5
20	M42 x 2	5,4	27,85 27,95	42,70 42,80	7,5	0,5	1,5 2,5	20,85 21,00	11,0	21,5	0,5

^a Thread D conforms to ISO 724; tolerances conform to ISO 965-1, grade 7G.

4.2 The size designation corresponds to the nominal hose size of the hose recommended for use with the coupling; see ISO 4397.

4.3 The shape of the sleeve can be round with wrench flats or hexagonal.

4.4 The female half and the male sleeve should be designed to guarantee relative rotation between the connected halves.

5 Performance requirements

5.1 Couplings conforming to this International Standard shall meet or exceed the performance requirements specified in [Table 2](#).

Table 2 — Performance requirements

Coupling size	Maximum working pressure	Minimum burst pressure		Rated flow rate	Maximum pressure drop at rated flow rate	Rated surge flow rate	Maximum fluid spillage
		Coupled	Uncoupled				
	MPa (bar) ^a	MPa (bar)	MPa (bar)	l/min	kPa (bar)	l/min	ml
6,3	35 (350)	140 (1 400)	140 (1 400)	12	250 (2,5)	36	0,8
10	30 (300)	120 (1 200)	120 (1 200)	23	200 (2)	69	1,4
12,5	30 (300)	120 (1 200)	120 (1 200)	45	150 (1,5)	135	2,7
20	25 (250)	100 (1 000)	100 (1 000)	106	220 (2,2)	318	9,3

^a 1 bar = 100 kPa = 10⁵ Pa = 0,1 MPa; 1 Pa = 1 N/m².

5.2 The performance requirements apply to couplings made from carbon steel. The use of any combination of other materials and the related performance requirements shall be agreed between the customer and the manufacturer.

5.3 The maximum working pressure shall be verified by a pressure impulse test conducted in accordance with ISO 7241-2 for 200 000 cycles in the uncoupled condition and 500 000 cycles in the coupled condition. The type, size, and tolerance class of the thread used on the counterpart of the coupling should be recorded in the test report.

5.4 The minimum burst pressure shall be verified in the coupled and uncoupled conditions by testing in accordance with ISO 7241-2.

5.5 The pressure drop at rated flow rate, fluid loss, and surge flow rate capability shall be verified by testing in accordance with ISO 7241-2.

5.6 Couplings shall be designed to be connected at 33 % of the maximum working pressure, which is considered to be the residual working pressure in one coupling half. Couplings shall pass the endurance test specified in ISO 7241-2 by connecting 100 times with an internal pressure of 33 % of the maximum working pressure without any damage to the coupling's functionality.

6 Assembly instruction

6.1 During coupling and uncoupling, torsion of hydraulic hoses shall be avoided. The use of a suitable tool is recommended to provide proper assembly; for example, a wrench or grip can be used to fix one half of the coupling during coupling and uncoupling.