



Designation: F2546 – 07

Standard Test Method for Snowboard Step-in Bindings¹

This standard is issued under the fixed designation F2546; the number immediately following the designation indicates the year of original adoption or, in the case of revision, the year of last revision. A number in parentheses indicates the year of last reapproval. A superscript epsilon (ϵ) indicates an editorial change since the last revision or reapproval.

1. Scope

1.1 This test method specifies the essential requirements for a snowboard step-in binding—boot system (see 3.1.2); hereafter referred to as step-in snowboard bindings.

1.2 This test method is applicable to step-in snowboard bindings for adults and children. This type of binding system utilizes a mechanical interlocking mechanism, and the interlock mechanism of the system will be specific to the particular manufacturer. Compatibility between different systems is not expected or anticipated thus each potential combination of boot and binding requires testing.

1.3 For snowboard boots interfacing with ski binding, see [ISO 11634](#).

1.4 For snowboard plate bindings, see [ISO 14790](#).

1.5 For snowboard strap bindings made for soft boots, see [ISO 14573](#).

1.6 For snowboard step-in bindings, see [ISO 15344](#).

1.7 This standard does not address how or under what circumstances a snowboard binding with programmable release modes should release in its intended modes nor does it

address the safety, desirability, or efficacy of any programmable release mode for snowboard bindings; any testing of such bindings to this standard must be performed with the release modes disabled or adjusted to their highest release value.

1.8 *This standard does not purport to address all of the safety concerns, if any, associated with its use. It is the responsibility of the user of this standard to establish appropriate safety and health practices and determine the applicability of regulatory limitations prior to use.*

2. Referenced Documents

2.1 *ASTM Standards*:²

[F1107 Terminology Relating to Snowboarding](#)

2.2 *ISO Standards*:³

[ISO 554:1976](#) Standard Atmospheres for Conditioning and/or Testing—Specifications

[ISO 6004](#) Alpine Skis—Ski Binding Screws—Requirements

¹ This test method is under the jurisdiction of ASTM Committee F27 on Snow Skiing and is the direct responsibility of Subcommittee F27.85 on Snowboarding.

Current edition approved June 1, 2007. Published July 2007. Originally approved in 2006. Last previous edition approved in 2006 as F2546 – 06. DOI: 10.1520/F2546-07.

² For referenced ASTM standards, visit the ASTM website, www.astm.org, or contact ASTM Customer Service at service@astm.org. For *Annual Book of ASTM Standards* volume information, refer to the standard's Document Summary page on the ASTM website.

³ Available from American National Standards Institute (ANSI), 25 W. 43rd St., 4th Floor, New York, NY 10036.

- ISO 10958-1 Snowboards—Binding Mounting Area—Part 1: Requirements and Test Methods for Snowboards without Inserts
- ISO 10958-2 Snowboards—Binding Mounting Area—Part 2: Requirements and Test Methods for Snowboards with Inserts
- ISO 11634 Snowboard Boots—Interface with Ski Binding
- ISO 14573 Snowboard Strap Bindings for Soft Boots
- ISO 14790 Snowboard Plate Bindings
- ISO 15344 Snowboard Step-in Bindings—Requirements and Test Methods

3. Terminology

3.1 Definitions:

3.1.1 *snowboard plate binding for hard boots*—a connecting system between a hard boot and a snowboard that is accomplished by means of a plate binding system. For reference only—not covered by this test method.

3.1.2 *snowboard step-in binding—boot system*—an interlocking system that connects a snowboard boot and a snowboard that utilizes a step-in interface.

3.1.3 *snowboard step-in binding type A*—binding suitable for riders over 45 kg body mass (adults).

3.1.4 *snowboard step-in binding type C*—binding suitable exclusively for a body mass up to 45 kg (children).

3.1.5 *snowboard strap binding for soft boots*—a connecting system between a soft boot and a snowboard that is accomplished by means of compression straps or other similar devices. For reference only—not covered by this test method.

3.2 Refer to Terminology F1107 for terminology specific to snowboarding.

4. Testing Parameters

4.1 This test method describes the steps required to evaluate a step-in snowboard binding system function. The test method consists of a series of laboratory tests that evaluate resistance to static and dynamic loading, function under cold and icy conditions, impact and fatigue behavior and assessment of potential false positive release. All tests must be passed.

4.2 All possible strains on the boot can be attributed to one torque M and one force F each on every axis X , Y , Z of a system of coordinates (see Fig. 1). The point of origin of the coordinates is agreed to be in the center of the ankle joint which is located approximately 100 mm from the plantar surface and 80 mm from the back of the heel.

4.3 The torques and forces illustrated in the drawing in Fig. 1 are positive. The corresponding parameters acting in opposite direction are given negative signs. The arrowheads indicate the sense of rotation of the snowboard boot movement.

5. Apparatus

5.1 One artificial leg with fixed ankle joint of 80° without toe section (see Fig. 2). Test size appropriate to the mid range of the sizing for the boot-binding system being tested.

5.2 A rigid plate (for example, steel plate of at least 10-mm thickness) with the appropriate mounting hole pattern for mounting the binding capable of supporting the applied loads and moments.

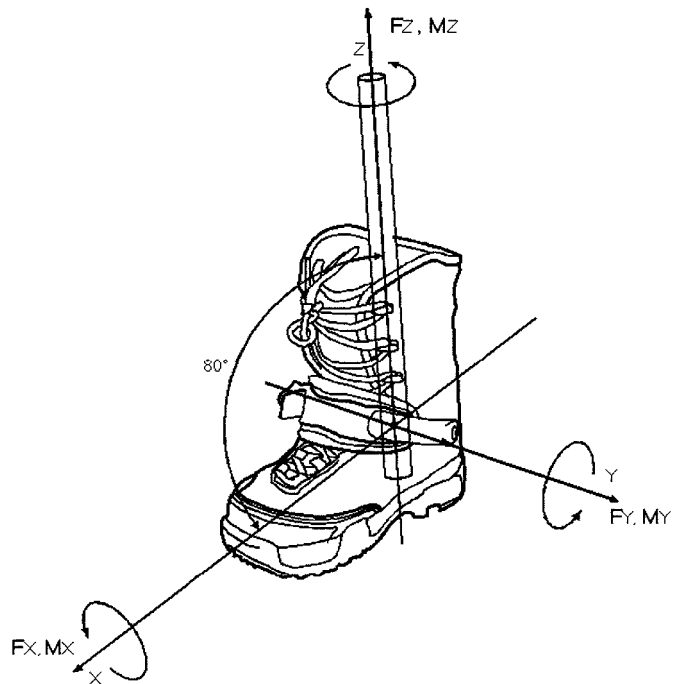

FIG. 1 Torques and Forces

5.3 Test device capable of applying the described forces and moments. The test device shall be designed to allow application of a torque (see Table 1) with a force applied at the upper part of a 1000-mm shaft connected to the artificial leg (see Fig. 2).

5.4 Fatigue test device for cyclic loading at the prescribed rates.

5.5 Impact test device capable of delivering a minimum of 120 J of energy at impact speeds up to 6 m/s.

6. Sampling and Conditioning

6.1 Three sample pairs of snowboard boots and bindings are to be used for lab testing. Use one new sample for each potentially destructive test method.

6.2 Unless otherwise noted, all tests shall be performed at room temperature (see ISO 554:1976). All sample boots and bindings shall be preconditioned at -20°C for a minimum of 90 min prior to testing. Unless otherwise noted, each test shall start within 2 min from when samples were removed from the cold. Surface temperature measurements should be made to ensure that sufficient conditioning time had been achieved.

7. Loading Rates

7.1 Perform the test quasi-statically, ensuring that the following indicative values of the torque gradient are respected:

7.1.1 *Torsion Values:*

$$\frac{dM_z}{dt} \leq 50 \text{ Nm/s} \quad (1)$$

7.1.2 *Forward Bending Value:*

$$\frac{dM_y}{dt} \leq 220 \text{ Nm/s} \quad (2)$$

7.1.3 *Lateral Bending:*