

---

---

**Garden equipment — Safety  
requirements for  
combustion-engine-powered  
lawnmowers —**

Part 3:

**Ride-on lawnmowers with seated  
operator**

(standards.iteh.ai)

*Matériel de jardinage — Exigences de sécurité pour les tondeuses à  
gazon à moteur à combustion interne —*

<https://standards.iteh.ai/catalog/standards/sist/b8553c8-b122-4d11-a70a-40fd32cf8441/iso-5395-3-2013>  
**Partie 3: Tondeuses à gazon à conducteur assis**



**iTeh STANDARD PREVIEW**  
**(standards.iteh.ai)**

ISO 5395-3:2013

<https://standards.iteh.ai/catalog/standards/sist/bfb553c8-b122-4df1-a70a-40fd32cf8441/iso-5395-3-2013>



**COPYRIGHT PROTECTED DOCUMENT**

© ISO 2013

All rights reserved. Unless otherwise specified, no part of this publication may be reproduced or utilized otherwise in any form or by any means, electronic or mechanical, including photocopying, or posting on the internet or an intranet, without prior written permission. Permission can be requested from either ISO at the address below or ISO's member body in the country of the requester.

ISO copyright office  
Case postale 56 • CH-1211 Geneva 20  
Tel. + 41 22 749 01 11  
Fax + 41 22 749 09 47  
E-mail [copyright@iso.org](mailto:copyright@iso.org)  
Web [www.iso.org](http://www.iso.org)

Published in Switzerland

# Contents

	Page
<b>Foreword</b> .....	<b>iv</b>
<b>Introduction</b> .....	<b>v</b>
<b>1 Scope</b> .....	<b>1</b>
<b>2 Normative references</b> .....	<b>1</b>
<b>3 Terms and definitions</b> .....	<b>2</b>
<b>4 Requirements for ride-on lawnmowers</b> .....	<b>2</b>
4.1 General.....	2
4.2 Controls.....	2
4.3 Operator presence control (OPC).....	6
4.4 Brakes.....	6
4.5 Guards.....	9
4.6 Stability.....	11
4.7 Rollover protective structure (ROPS).....	12
4.8 Seat belts.....	12
4.9 Seats and foot rests.....	13
4.10 Transport position of the cutting-means assembly.....	14
4.11 Separate fan for grass collection.....	14
4.12 Hot surfaces.....	15
4.13 Exhaust fumes.....	15
4.14 Pressurized components of hydraulic systems.....	15
4.15 Liquid spillage.....	15
4.16 Electrical system.....	16
4.17 Electromagnetic immunity.....	16
4.18 Noise.....	17
4.19 Vibration.....	17
<b>5 Particular requirements for ride-on rotary lawnmowers</b> .....	<b>18</b>
5.1 Cutting means.....	18
5.2 Impact of the cutting means.....	19
5.3 Cutting-means enclosure.....	19
5.4 Structural integrity.....	23
5.5 Thrown objects.....	23
5.6 Grass catchers.....	24
<b>6 Particular requirements for ride-on cylinder lawnmowers</b> .....	<b>24</b>
6.1 Cutting-means enclosure.....	24
6.2 Throw line.....	27
6.3 Stopping time of the cutting means.....	27
<b>7 Information for use</b> .....	<b>27</b>
7.1 Instruction handbook.....	27
7.2 Markings and warnings.....	30
<b>Annex A (normative) Ride-on lawnmower stability test</b> .....	<b>33</b>
<b>Annex B (normative) Determination of contact with moving power-driven components</b> .....	<b>36</b>
<b>Annex C (informative) List of significant hazards</b> .....	<b>40</b>
<b>Bibliography</b> .....	<b>42</b>

## Foreword

ISO (the International Organization for Standardization) is a worldwide federation of national standards bodies (ISO member bodies). The work of preparing International Standards is normally carried out through ISO technical committees. Each member body interested in a subject for which a technical committee has been established has the right to be represented on that committee. International organizations, governmental and non-governmental, in liaison with ISO, also take part in the work. ISO collaborates closely with the International Electrotechnical Commission (IEC) on all matters of electrotechnical standardization.

International Standards are drafted in accordance with the rules given in the ISO/IEC Directives, Part 2.

The main task of technical committees is to prepare International Standards. Draft International Standards adopted by the technical committees are circulated to the member bodies for voting. Publication as an International Standard requires approval by at least 75 % of the member bodies casting a vote.

Attention is drawn to the possibility that some of the elements of this document may be the subject of patent rights. ISO shall not be held responsible for identifying any or all such patent rights.

ISO 5395-3 was prepared by the European Committee for Standardization (CEN) Technical Committee CEN/TC 144, *Tractors and machinery for agriculture and forestry* in collaboration with ISO Technical Committee TC 23, *Tractors and machinery for agriculture and forestry*, Subcommittee SC 13, *Powered lawn and garden equipment*, in accordance with the Agreement on technical cooperation between ISO and CEN (Vienna Agreement).

This second edition of ISO 5395-3, together with ISO 5395-1 and ISO 5395-2, cancels and replaces ISO 5395:1990, which has been technically revised. These three parts also incorporate the Amendment ISO 5395:1990/Amd.1:1992.

ISO 5395 consists of the following parts, under the general title *Garden equipment – Safety requirements for combustion-engine-powered lawnmowers*:

- Part 1: Terminology and common tests
- Part 2: Pedestrian-controlled lawnmowers
- Part 3: Ride-on lawnmowers with seated operator

## Introduction

This document is a type-C standard as stated in ISO 12100.

The machinery concerned and the extent to which hazards, hazardous situations or hazardous events are covered are indicated in the scope of this document.

When requirements of this type-C standard are different from those which are stated in type-A or type-B standards, the requirements of this type-C standard take precedence over the requirements of the other standards for machines that have been designed and built according to the requirements of this type-C standard.

## iTeh STANDARD PREVIEW (standards.iteh.ai)

[ISO 5395-3:2013](https://standards.iteh.ai/catalog/standards/sist/bfb553c8-b122-4df1-a70a-40fd32cf8441/iso-5395-3-2013)

<https://standards.iteh.ai/catalog/standards/sist/bfb553c8-b122-4df1-a70a-40fd32cf8441/iso-5395-3-2013>

**iTeh STANDARD PREVIEW**  
**(standards.iteh.ai)**

ISO 5395-3:2013

<https://standards.iteh.ai/catalog/standards/sist/bfb553c8-b122-4df1-a70a-40fd32cf8441/iso-5395-3-2013>

# Garden equipment — Safety requirements for combustion-engine-powered lawnmowers —

## Part 3: Ride-on lawnmowers with seated operator

### 1 Scope

**1.1** This part of ISO 5395 specifies safety requirements and their verification for combustion-engine-powered ride-on (seated) rotary lawnmowers and cylinder lawnmowers (hereafter named “lawnmower”), and equipped with:

- metallic cutting means; and/or
- non-metallic cutting means with one or more cutting elements pivotally mounted on a generally circular drive unit, where these cutting elements rely on centrifugal force to achieve cutting, and have a kinetic energy for each single cutting element of 10 J or more.

This part of ISO 5395 does not apply to:

- robotic and remote-controlled lawnmowers, flail mowers, grassland mowers, sickle bar mowers, towed/semi-mounted grass-cutting machines, and scrub-clearing machines;
- cutting-means assembly when used in combination with an agricultural tractor;
- electrically powered and battery-powered lawnmowers.

**1.2** This part of ISO 5395 deals with all significant hazards, hazardous situations or events (see [Annex C](#)) relevant to lawnmowers when used as intended and under the conditions of misuse which are reasonably foreseeable by the manufacturer.

**1.3** This part of ISO 5395 is not applicable to lawnmowers which are manufactured before the date of publication of this document.

### 2 Normative references

The following documents, in whole or in part, are normatively referenced in this document and are indispensable for its application. For dated references, only the edition cited applies. For undated references, the latest edition of the referenced document (including any amendments) applies.

IEC 61032:1997, *Protection of persons and equipment by enclosures — Probes for verification*

ISO 3776-2:2013, *Tractors and machinery for agriculture — Seat belts — Part 2: Anchorage strength requirements*

ISO 3776-3:2009, *Tractors and machinery for agriculture — Seat belts — Part 3: Requirements for assemblies*

ISO 5353, *Earth-moving machinery, and tractors and machinery for agriculture and forestry — Seat index point*

ISO 5395-1:2013, *Garden equipment — Safety requirements for combustion-engine-powered lawnmowers — Part 1: Terminology and common tests*

ISO 12100:2010, *Safety of machinery — General principles for design — Risk assessment and risk reduction*

ISO 13849-1:2006, *Safety of machinery — Safety-related parts of control systems — Part 1: General principles for design*

ISO 13857:2008, *Safety of machinery — Safety distances to prevent hazard zones being reached by upper and lower limbs*

ISO 14119:1998, *Safety of machinery — Interlocking devices associated with guards — Principles for design and selection*

ISO 14982:1998, *Agricultural and forestry machinery — Electromagnetic compatibility — Test methods and acceptance criteria*

ISO 17398:2004, *Safety colours and safety signs — Classification, performance and durability of safety signs*

ISO 21299:2009, *Powered ride-on turf care equipment — Roll-over protective structures (ROPS) — Test procedures and acceptance criteria*

### **3 Terms and definitions**

For the purposes of this document, the terms and definitions given in ISO 12100 and ISO 5395-1 apply.

## **4 Requirements for ride-on lawnmowers**

### **4.1 General**

The lawnmower shall comply with the safety requirements and/or protective measures of this clause. The lawnmower shall be marked and carry warnings according to 7.2 and shall be provided with an instruction handbook which complies with 7.1.

In addition, the lawnmower shall be designed according to the principles of ISO 12100 for relevant but not significant hazards which are not dealt with by this part of ISO 5395. An audible warning device (for example, a horn) is not required.

Unless otherwise stated, all tests shall be carried out at an ambient temperature between 15 °C and 35 °C.

If not otherwise specified within this part of ISO 5395, the tests may be carried out in any order and on separate machines, cutting-means enclosures, and cutting-means components.

When the order in which tests should be carried out and the number of permitted machines are not defined in this part of ISO 5395, these conditions should be determined by agreement between the persons carrying out the tests and the manufacturer.

Where it is specified that the engine shall run during the test, it shall be operated at the maximum operating engine speed (see definition in ISO 5395-1). If the measured engine speed is not within the limits specified in the instruction handbook, the engine speed shall be adjusted in accordance with the manufacturer's instructions.

### **4.2 Controls**

#### **4.2.1 General**

Separate controls shall be provided for the traction drive and cutting-means engagement.

Directional control mechanisms that cause forward and reverse propulsion as well as forward and reverse speed control shall have a neutral position.

Except for lever-steer lawnmowers, when released, a traction drive speed control shall automatically return to the neutral position or shall be capable of being overridden by the service brake.

Foot control pedals shall have slip-resistant surfaces or other means of minimizing the possibility of the operator's foot slipping off the control pedal.



Except for lever-steer lawnmowers, forward/reverse directional controls shall require at least one of the following:

- a) a distinct change in direction of the control actuation (for example, right angle to general path of control motion) at a point before a change in direction occurs; or
- b) a distinct change in force level at the point of entry into the selected direction; or
- c) a positive means of retarding machine acceleration, for example hydrostatic control with valves operated by rigid linkages.

The traction drive and cutting means shall automatically stop or disengage when the operator leaves the operating position.

*Compliance shall be checked by functional test and inspection to demonstrate that it meets the above requirements.*

The location of operator controls, to be operated from the operator's position during grass cutting, shall be within the zones of [Figure 1](#) for an operator in the required operator position.

The operator control zone defined in [Figure 1](#) includes the maximum movement range of the controls but is not intended to represent preferred operator control positions.

For the seated operator, the operator control zone is established with the seat in the rear-most position.

NOTE ISO/TS 15079<sup>[10]</sup> gives useful information about location and operation of operator controls.

For the purpose of this clause, the following shall not be considered as operator controls that are operated during grass cutting: **(standards.iteh.ai)**

- height-of-cut setting;
- fixed cutting-means setting or adjustment;
- grass catcher discharge opening;
- hydrostatic bypass valve;
- engine-starting controls which meet [4.2.3](#);
- engine-stopping controls if separate from cutting-means stopping control;
- parking brake.

*Compliance shall be checked by inspection and measurement.*

Dimensions in millimetres, tolerances  $\pm 3$  mm

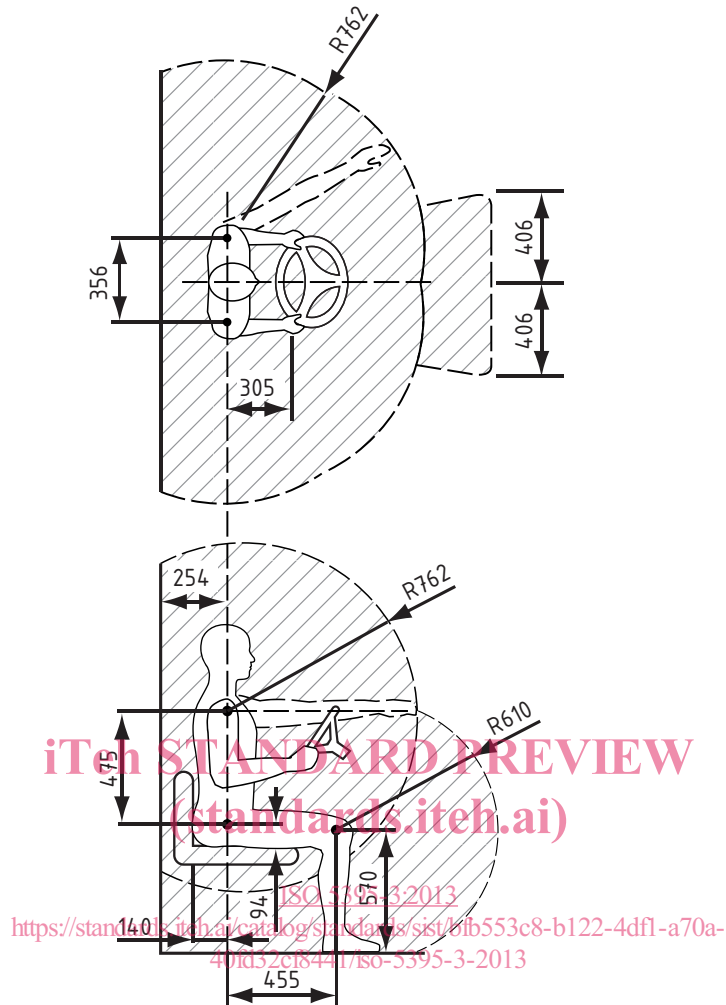

**Figure 1 — Operator control zone for seated operator**

NOTE The operator control zone, illustrated in [Figure 1](#) is the area into which the extremities of a 95th percentile male can reach from the normal operator position.

**4.2.2 Engine speed**

The lawnmower shall be designed so that it is not possible to sustain an engine speed greater than the maximum operating engine speed (see definition in ISO 5395-1) by the use of any control or without replacing or reconfiguring engine speed control components.

*Compliance shall be checked by inspection and measurement.*

**4.2.3 Engine-starting device**

Any engine-starting device (e.g. start switch, recoil rope starter) shall require intentional activation in order to start the engine.

A starter operated by means of a loose rope is not allowed.

For battery started engines, the start switch shall be operated by a removable key or a similar device to prevent unauthorized starting.

The engine shall only start if the:

- operator is in position or parking brake is applied; and
- traction drive and cutting means are disengaged.

*Compliance shall be checked by functional test and inspection.*

#### 4.2.4 Engine-stopping device

An engine-stopping device shall be provided. The device shall not depend on sustained manual pressure for its continued operation.

NOTE An emergency stop device is not required.

*Compliance shall be checked by functional test and inspection.*

#### 4.2.5 Steering wheel

If the lawnmower is equipped with a steering wheel, when moving forward a clockwise rotation shall effect a right turn and counter-clockwise rotation shall effect a left turn.

During operation, the steering mechanism shall not lock in any position.

*Compliance shall be checked by functional test and inspection.*

#### 4.2.6 Lever steering and motion controls

##### 4.2.6.1 General

If the lawnmower is equipped with lever(s) for directional control, movement of the lever(s) forward shall result in forward motion, and movement of the lever(s) rearward shall result in rearward motion. If the operator releases the levers while in the rearward position, the directional controls shall automatically return to the neutral position or the machine's rearward motion shall stop.

*Compliance shall be checked by functional test and inspection.*

##### 4.2.6.2 Lawnmower with two control levers

Movement of the right lever shall control the right drive wheel. Movement of the left lever shall control the left drive wheel. The lawnmower shall turn right when the left lever is displaced further in the direction of the machine travel than the right lever. The lawnmower shall turn left when the right lever is displaced further in the direction of the machine travel than the left lever.

*Compliance shall be checked by functional test and inspection.*

##### 4.2.6.3 Lawnmower with a single control lever

For the lawnmower with lateral displacement for the steering control, the lawnmower shall turn right when the lever is moved to the right. The lawnmower shall turn left when the lever is moved to the left.

For the lawnmower with rotational displacement for the steering control, a clockwise movement of the control about its axis shall effect a clockwise turn of the machine about its axis, and a counter clockwise movement shall effect a counter clockwise turn.

*Compliance shall be checked by functional test and inspection.*

#### 4.2.7 Traction speed and braking control

If the lawnmower is equipped with lever(s) for traction speed and braking, then increased displacement of the lever(s) shall produce increased traction speed. A neutral position shall be provided. Lever motion in a direction opposite that of machine travel shall be accepted as engagement of the service brakes.

*Compliance shall be checked by functional test and inspection and tested according to the brake test in 4.4.1.*

### 4.3 Operator presence control (OPC)

#### 4.3.1 General

The lawnmower shall be fitted with an operator presence control device which:

- meets the category 1 requirements in ISO 13849-1:2006, Clause 6; and,
- requires activation by the operator before the lawnmower's traction and cutting-means drive systems can be started; and
- requires continuous activation by the operator to allow rotation of the cutting means and the activation of the traction drive; and
- automatically activates the stopping of the cutting-means rotation and traction drive when the operator leaves the operating position used when cutting grass.

NOTE The hazards from failure of the OPC system, use of performance level (PL) and difficulty to neutralize the OPC, as well as the use of a slope indicator, are under review.

From a complete stop position, restarting of cutting-means rotation shall require two separate and distinct actions. Activation of the OPC shall be one of the actions. If these actions are to be carried out using the same hand, then the actions shall be separate and dissimilar to prevent accidental restarting of the cutting means.

If the OPC is reactivated without the operator leaving the operator's position and before the cutting means and/or traction drive have stopped, the cutting-means and/or traction drive can resume operation if there is sufficient kinetic energy to restart the engine.

Automatic or single-action stopping and starting of the cutting means shall be allowed during continuous operation of the OPC.

*Compliance shall be checked by functional test and inspection.*

### 4.4 Brakes

#### 4.4.1 Service brake performance

##### 4.4.1.1 Requirements

The lawnmower shall be equipped with a service brake.

The service brake shall meet the following requirements:

- the service brake performance shall only rely on the effectiveness of the braking system; and
- the service brake control device shall be located within the operator control zone (see [Figure 1](#)) and its position shall not interfere with the position of other controls; and
- if the lawnmower is equipped with combined traction clutch and brake controls, the service brake engagement shall simultaneously disengage the traction clutch; and

- for lawnmowers with a maximum speed up to and including 13 km/h, the service brake shall be capable of stopping the lawnmower's motion so that the average measured stopping distance does not exceed 0,19 m for each 1 km/h of the maximum forward speed and maximum reverse speed, if a reverse traction drive is provided; and
- for lawnmowers with a maximum speed greater than 13 km/h, the service brake shall be capable of stopping the lawnmower's motion so that the average measured stopping distance in metres does not exceed  $0,015 \cdot v^2$  where  $v$  is the maximum speed in km/h forward speed and maximum reverse speed, if a reverse traction drive is provided.

The service brake system can be provided by a hydrostatic, electric or mechanical drive.

*Compliance shall be checked by functional test and inspection and tested in accordance with [4.4.1.2](#).*

#### 4.4.1.2 Service brake test

- a) The tests shall be conducted on a lawnmower:
  - 1) in its heaviest design configuration as available from the manufacturer, with grass catcher filled to its maximum volumetric capacity with material of density  $150 \text{ kg/m}^3 \pm 10 \text{ kg/m}^3$ ; and
  - 2) with full fuel tanks; and
  - 3) with pneumatic tyres inflated to the maximum recommended pressures for the lawnmower; and
  - 4) with brakes adjusted in accordance with the manufacturer's instructions; and,
  - 5) with a  $90 \text{ kg} \pm 0,5 \text{ kg}$  operator, or an equivalent weight. The operator, if present, shall sit or stand upright without any intentional leaning in any direction during the test.
- b) The tests shall be conducted on a dry, smooth, hard concrete (or equivalent) surface with a maximum slope of 1 %. <https://standards.iteh.ai/catalog/standards/sist/bfb553c8-b122-4df1-a70a-40f132cf8441/iso-5395-3-2013>
- c) First condition the service brake system by running the lawnmower for 10 min during which 10 stops shall be performed from the maximum forward speed. If a reverse traction drive is provided, this break-in period shall be extended to 20 min during which the service brakes shall be applied to stop the machine 10 times from maximum forward speed, and 10 times from maximum reverse speed.
- d) If the lawnmower is equipped with separate traction clutch and service brake controls, the traction clutch shall be simultaneously disengaged with the service brake engagement.
- e) After the conditioning procedure has been completed, the service brake test shall be conducted three times in the forward direction of travel and, if provided with a reverse traction drive, repeated three times in the reverse direction of travel.
- f) Operate the lawnmower at its maximum ground speed and apply a maximum force of:
  - 1) 220 N to the centre of the grip area of the hand control; or
  - 2) 450 N for a foot-operated service brake on lawnmowers not having a backrest on the seat; or
  - 3) 600 N for a foot-operated service brake on lawnmowers with a backrest on the seat.

NOTE The forces 220 N, 450 N and 600 N are considered as maximum forces that can be applied to meet the test requirements. The operating forces during normal use would, in general, be less.
- g) Measure the stopping distances for each brake test and calculate the average value for each direction tested.

## 4.4.2 Service brake strength

### 4.4.2.1 Requirement

Except for hydrostatic or electric drive systems the service brake system shall, without loss of function, withstand an overload of applied force which shall be:

- 1 670 N  $\pm$  50 N for foot-operated brakes; or
- 625 N  $\pm$  25 N for hand-operated brakes.

Compliance is verified by applying the force for 5 s on each brake control, in the direction of brake actuation. After release of the applied force on the brake control, the service brake system shall meet the requirements of [4.4.1.1](#).

## 4.4.3 Parking brake

### 4.4.3.1 Requirements

Lawnmowers equipped with a service brake shall also be equipped with a parking brake. The parking brake shall be capable of holding the lawnmower on a slope up to and including 16,7° (30 %) facing both up hill and downhill.

To allow the removal of initial slack in the system, a distance of 50 mm movement is allowed during the first 30 s, after the parking brake has been applied. There shall be no further movement after the 30 s.

The parking brake can be combined with the service brake.

The maximum force to actuate the parking brake shall not exceed:

- 220 N for a hand-grip parking brake, actuated by hand gripping motion only; or
- 330 N for a hand-lever parking brake, actuated by arm motion with a hand on a lever; or
- 450 N for a foot-operated parking brake on lawnmowers not having a backrest on the seat; or
- 600 N for a foot-operated parking brake on lawnmowers with a backrest on the seat.

NOTE The forces 220 N, 330 N, 450 N and 600 N are considered as maximum forces that can be applied to meet the test requirements of [4.4.3.2](#). The operating forces during normal use would, in general, be less.

The unlocking force shall be minimum 100 N and shall not exceed the maximum specified actuating force or shall require two dissimilar actions.

*Compliance shall be checked by functional test and inspection and tested in accordance with [4.4.3.2](#).*

### 4.4.3.2 Parking brake test

- a) The tests shall be conducted on the same lawnmower and under the same conditions as in the service brake test. The transmission shall be in neutral and the engine shall be stopped. If so equipped, the hydrostatic bypass valve shall be in the normal working position of the machine.
- b) The tests shall be conducted on a smooth flat surface with 16,7° (30 %) slope, and a coefficient of friction such that the lawnmower does not slide down the slope.
- c) A 90 kg  $\pm$  0,5 kg operator, or equivalent weight, shall be positioned on the lawnmower seat. If an equivalent weight is used, it shall be securely fastened to the seat to simulate an operator. The centre of gravity of the mass shall be 150 mm  $\pm$  5 mm above the lowest point of the operator supporting surface of the seat and 250 mm  $\pm$  5 mm forward of the seat back. If a seat back is not used, the forward measurement of 250 mm  $\pm$  5 mm shall be measured from the back of an actual seated operator.

- d) The parking brake shall be applied.
- e) The test shall be conducted for a period of 5 min, or if the parking brake is hydrostatic, the test period shall be 60 min.

## 4.5 Guards

### 4.5.1 Detaching or opening of guards

The opening or detaching of guards shall require the use of a tool except for:

- a) interlocked guards, in accordance with ISO 14119, which prevent access before the moving parts have come to a complete stop. While the hazardous part is exposed, it shall not be possible to apply power to it;
- b) the opening of automatically closing guards for grass discharge chutes. Such a guard shall remain in its operating position when:
  - 1) the lawnmower is operated on the coconut matting of ISO 5395-1:2013, E.6; and
  - 2) the cutting means are engaged and operated at maximum operating engine speed; and
  - 3) the cutting means are adjusted to the lowest and highest cutting positions;
- c) engine compartment access of machines where the operator presence control stops the engine.

Fixed guards shall be fixed by systems that can be opened or removed only with tools. A fixed guard that has to be removed as a part of maintenance procedures as described in the instruction handbook, shall be retained by fixing system that shall remain attached to the guard or to the machinery when the guard is removed.

Where possible, fixed guards shall be incapable of remaining in place without their fixings.

*Compliance shall be checked by functional test and inspection. Compliance via the foot protection test in [5.3.2](#) shall be determined with the lawnmower engine and cutting means stopped.*

### 4.5.2 Prevention of contact with a power-driven component

Power-driven components, except the cutting means and ground-contacting parts, shall be guarded so they are not accessible according to [Annex B](#).

Requirements for cutting means are given in [Clause 5](#) for rotary lawnmowers and [Clause 6](#) for cylinder lawnmowers.

Outside the testing zones defined in [Annex B](#), access to moving power-driven components shall comply with the requirements of ISO 13857:2008, 4.2.4.1 or 4.2.4.3, Table 4.

*Compliance shall be checked by inspection and functional test in accordance with [Annex B](#).*

### 4.5.3 Prevention of operator contact with moving power-driven components from the driving position

All moving power-driven components, except the cutting means and ground-contacting parts, shall be guarded to prevent contact with these components during normal operation for grass cutting.

Requirements for cutting means are given in [Clause 5](#) for rotary lawnmowers and [Clause 6](#) for cylinder lawnmowers.