Testing of ceramic raw and basic materials — Determination of sulfur in powders and granules of non-oxidic ceramic raw and basic materials —

Part 2:

Inductively coupled plasma optical emission spectrometry (ICP/OES) or ion chromatography after burning in an oxygen flow

[https://standards.iteh.ai/catalog/standards/sist/c5a967b2-b676-4a76-b973-](https://standards.iteh.ai/catalog/standards/sist/c5a967b2-b676-4a76-b973-10047822013)

Essais des matières premières pour produits réfractaires — Dosage du soufre dans les matières premières non oxydantes sous forme de poudre et de granulés —

Partie 2: Spectrométrie d'émission optique avec plasma induit par haute fréquence (ICP/OES) ou chromatographie ionique après combustion dans un courant d'oxygène



iTeh STANDARD PREVIEW
(standards.iteh.ai)

ISO 14720-2:2013

<https://standards.iteh.ai/catalog/standards/sist/c5a967b2-b676-4a76-b973-a73bc08099b5/iso-14720-2-2013>



COPYRIGHT PROTECTED DOCUMENT

© ISO 2013

All rights reserved. Unless otherwise specified, no part of this publication may be reproduced or utilized otherwise in any form or by any means, electronic or mechanical, including photocopying, or posting on the internet or an intranet, without prior written permission. Permission can be requested from either ISO at the address below or ISO's member body in the country of the requester.

ISO copyright office
Case postale 56 • CH-1211 Geneva 20
Tel. + 41 22 749 01 11
Fax + 41 22 749 09 47
E-mail copyright@iso.org
Web www.iso.org

Published in Switzerland

Contents

	Page
Foreword	iv
1 Scope	1
2 Normative references	1
3 Terms and definitions	1
4 Principle	1
5 Interferences	2
5.1 ICP/OES	2
5.2 Ion chromatography	2
6 Apparatus	3
7 Reagents	3
8 Sampling and sample preparation	4
9 Preparation	4
9.1 Combustion device	4
9.2 Oxygen (7.10)	4
9.3 Inductively coupled plasma optical emission spectrometer (6.7)	4
9.4 Ion chromatograph (6.8)	4
10 Calibration	4
10.1 Inductively coupled plasma optical emission spectrometer	4
10.2 Ion chromatograph	4
11 Performance	5
11.1 Determination of the blank value	5
11.2 Determination of the sulfur content	5
12 Calculation and report of the results	5
13 Precision	6
13.1 Repeatability	6
13.2 Reproducibility	6
14 Test report	6
Annex A (informative) Example of a combustion device	7
Annex B (informative) Example for suitable operating parameters for the determination of sulfur by ion chromatography	8
Annex C (informative) Example for suitable operating parameters for the determination of sulfur by inductively coupled plasma optical emission spectroscopy	9
Annex D (informative) Results of the round-robin test	10
Annex E (informative) Information regarding the validation of the uncertainty of the mean value	13
Annex F (informative) Commercial Certified Reference Materials (CRM)	14
Bibliography	15

Foreword

ISO (the International Organization for Standardization) is a worldwide federation of national standards bodies (ISO member bodies). The work of preparing International Standards is normally carried out through ISO technical committees. Each member body interested in a subject for which a technical committee has been established has the right to be represented on that committee. International organizations, governmental and non-governmental, in liaison with ISO, also take part in the work. ISO collaborates closely with the International Electrotechnical Commission (IEC) on all matters of electrotechnical standardization.

International Standards are drafted in accordance with the rules given in the ISO/IEC Directives, Part 2.

The main task of technical committees is to prepare International Standards. Draft International Standards adopted by the technical committees are circulated to the member bodies for voting. Publication as an International Standard requires approval by at least 75 % of the member bodies casting a vote.

Attention is drawn to the possibility that some of the elements of this document may be the subject of patent rights. ISO shall not be held responsible for identifying any or all such patent rights.

ISO 14720-2 was prepared by Technical Committee ISO/TC 33, *Refractories*.

ISO 14720 consists of the following parts, under the general title *Testing of ceramic raw and basic materials — Determination of sulfur in powders and granules of non-oxidic ceramic raw and basic materials*:

- *Part 1: Infrared measurement methods*
- *Part 2: Inductively coupled plasma optical emission spectrometry (ICP/OES) or ion chromatography after burning in an oxygen flow*

STANDARD PREVIEW
(standards.iteh.ai)
<https://standards.iteh.ai/catalog/standards/sist/c5a967b2-b676-4a76-b973-a73bc08099b5/iso-14720-2-2013>

Testing of ceramic raw and basic materials — Determination of sulfur in powders and granules of non-oxidic ceramic raw and basic materials —

Part 2:

Inductively coupled plasma optical emission spectrometry (ICP/OES) or ion chromatography after burning in an oxygen flow

1 Scope

This part of ISO 14720 defines a method for the determination of sulfur in powdered and granular non-oxidic ceramic raw materials and materials, which are completely oxidized at a higher temperature in an oxygen atmosphere, e.g. carbon and graphite materials.

For materials which are not completely oxidizable under these conditions, it is possible to determine sulfur that can be released under these conditions, e.g. the adherent sulfur.

This part of ISO 14720 is applicable for materials with mass fractions of sulfur $\leq 10\%$ and mass fractions of ash $< 20\%$. The defined method is limited for materials with mass fractions of barium $< 10\text{ mg/kg}$, because the sulfur bonded in barium sulfate is not detectable with this method.

For the lower detection limit of this method, a mass fraction of sulfur of $0,5\text{ mg/kg}$ in the case of inductively coupled plasma optical emission spectrometry (ICP/OES) and 5 mg/kg in the case of ion chromatography (IC) has to be considered as a recommended value.

2 Normative references

The following referenced documents are indispensable for the application of this document. For dated references, only the edition cited applies. For undated references, the latest edition of the referenced document (including any amendments) applies.

ISO 11885, *Water quality — Determination of selected elements by inductively coupled plasma optical emission spectrometry (ICP-OES)*

ISO 10304-1, *Water quality — Determination of dissolved anions by liquid chromatography of ions — Part 1: Determination of bromide, chloride, fluoride, nitrate, nitrite, phosphate and sulfate*

3 Terms and definitions

For the purposes of this document, the following terms and definitions apply.

3.1

sulfur content

mass fraction of inorganic and organic bound sulfur

4 Principle

The dried sample is oxidized in a flow of oxygen at a temperature of $1\ 100\text{ °C}$ using a porcelain crucible. The resulting sulfur oxides are absorbed in a solution of sodium hydroxide and hydrogen peroxide. The

remaining material (ash) is dissolved and combined with the absorption liquid in the case of calcium-sulfate-containing sample material. The concentration of sulfur in the sample solution is determined by inductively coupled plasma optical emission spectrometry (ICP/OES) according to ISO 11885 or by ion chromatography (IC) as sulfate according to ISO 10304-1.

5 Interferences

5.1 ICP/OES

5.1.1 Spectral interferences

The compensation of spectral interferences is performed according to the manual of the manufacturer of the spectrometer.

NOTE 1 Spectral interferences can be caused by:

- a) Overlapping with the emission line of another element;
- b) Overlapping with molecular bands;
- c) Unspecific background (e.g. scattering, recombinations).

Overlapping of lines can be compensated for by arithmetical correction of the raw data if applicable.

Correction factors are determined by measuring at least one undisturbed additional emission line of the interfering element and considering the relation of the intensity of this emission line to the emission line which interferes with the analyte element.

In the case of overlapping with molecular bands, an alternative emission line has to be chosen.

NOTE 2 Unspecific background is usually compensated for by measuring the background signal in the surroundings of the analyte emission line.

5.1.2 Physical interferences

To compensate physical interferences, suitable measures shall be taken.

NOTE Physical interferences occur as plasma interferences or as transport interferences. Both are caused by a different behaviour of the calibration solution compared to the sample solution based on a different chemical composition. Plasma interferences are caused by changes in plasma conditions, e.g. temperature distribution and electron density, leading to a changed excitation of emission lines. Transport interferences are caused by differences in physical characteristics of the calibration solution and sample solution, mainly density, viscosity and surface tension.

Some of the transport interferences can be reduced by using appropriate (peristaltic) pumps. Plasma interferences as well as transport interferences can be reduced significantly by using suitable reference lines of a reference element with the same concentration in both the calibration and analyte solution (internal standard). Other possibilities are to equalize the chemical composition of the calibration and sample solution as much as possible (matrix matching) or to use a standard addition procedure or a standard addition calibration procedure instead of the standard calibration procedure.

5.2 Ion chromatography

To avoid cross-interferences by additional anions, suitable measures shall be taken.

NOTE Anions like chloride, bromide, fluoride, nitrite, nitrate, formate and acetate in the absorption liquid may lead to cross-interferences. By using the chromatographic parameters given in [Annex B](#), the sulfate signal usually can be separated completely from the signals of the other anions.

6 Apparatus

6.1 Combustion device, adjustable to $(1\ 100 \pm 20)$ °C, suitable for oxidizing the sample in an oxygen flow and suitable to absorb the reaction gases completely.

NOTE For an example of a suitable device see [Annex A](#).

6.2 Porcelain boat, unglazed.

6.3 Gas-washing bottles, standard type, nominal volume 100 ml, filled with 25 ml of absorption solution (7.6 and [Annex A](#)).

6.4 Filtration adaptor, with a membrane filter with a pore width of 0,45 µm, connectable to the outlet of the disposable syringe ([6.5](#)).

6.5 Disposable syringe, nominal volume 5 ml.

6.6 Ultrasonic bath, preferably with a volume of ≥ 1 l and an ultrasonic power of ≥ 150 W.

6.7 Inductively coupled plasma optical emission spectrometer, sequential or simultaneous spectrometer with a lower wavelength limit of at least 180 nm.

6.8 Ion chromatograph with a column for anions and conductivity detector, if available with suppressor technique.

iTech STANDARD PREVIEW
(standards.iteh.ai)

7 Reagents

[ISO 14720-2:2013](#)

<https://standards.iteh.ai/catalog/standards/sist/c5a967b2-b676-4a76-b973-a73bc08099b5/iso-14720-2-2013>

7.1 General

Reagents of known analytical grade shall be used, provided it is first ascertained that the reagent is of sufficiently high purity to permit its use without lessening the accuracy of the determination.

7.2 Hydrogen peroxide solution, H_2O_2 , $w(\text{H}_2\text{O}_2) = 30\%$.

7.3 Sodium hydroxide solution, NaOH, $c(\text{NaOH}) = 0,001$ mol/l.

7.4 Hydrochloric acid, HCl, $w(\text{HCl}) = 18\%$.

7.5 Ultrapure water, with a specific resistance of $18\ \text{M}\Omega \cdot \text{cm}$ (at 25 °C).

7.6 Absorption solution, sodium hydroxide solution ([7.3](#)) and hydrogen peroxide solution ([7.2](#)) mixed in a ratio of 9:1.

7.7 Sulfate standard stock solution, certified single- or multi-element standard stock solution, preferably with a concentration of 1 000 µg/ml for sulfur.

7.8 Calibration solution, at least two calibration solutions have to be prepared by dilution of the standard stock solution ([7.7](#)) with water ([7.5](#)) according to the expected sulfur concentrations.

7.9 Eluent, exclusively for IC; for its use the instructions of the manufacturer have to be followed.

NOTE Depending on the column different eluents are used. For a suitable eluent see [Annex B](#).

7.10 **Oxygen**, from a compressed gas cylinder, purity $\geq 99,998\%$ V/V.

8 Sampling and sample preparation

Sampling shall be performed in such a way that the sample to be analysed is representative for the total amount of material, for example according to ISO 8656-1.^[1]

The sample material shall have a particle size of $\leq 160\ \mu\text{m}$; if necessary, it shall be crushed and homogenized. Samples which incinerate completely can be used without crushing provided they fit into the porcelain boat (6.2).

In an unknown drying state, the sample shall be dried at $(110 \pm 5)\text{ }^\circ\text{C}$ to constant mass. The sample is cooled down to ambient temperature in a desiccator and stored therein.

It is important to avoid any contamination of the sample by improper handling (e.g. touching by fingers).

9 Preparation

9.1 Combustion device

The temperature of the combustion zone has to be adjusted to $(1\ 100 \pm 20)\text{ }^\circ\text{C}$.

9.2 Oxygen (7.10)

Oxygen from the compressed gas cylinder is taken out by using a pressure-reduction valve. The oxygen flow is adjusted to $(20 \pm 10)\text{ l/h}$ with a gas flow controller.

9.3 Inductively coupled plasma optical emission spectrometer (6.7)

Use the procedures recommended by the manufacturer of the instrument as set down in the operating procedure. The wavelength for sulfur at 180,731 nm and 182,034 nm should be used.

NOTE For recommendations for operating the inductively coupled plasma optical emission spectrometer (6.7), see Annex C.

9.4 Ion chromatograph (6.8)

Use the procedures recommended by the manufacturer of the instrument as set down in the operating procedure.

NOTE For recommendations for operating the ion chromatograph (6.8), see Annex B.

10 Calibration

10.1 Inductively coupled plasma optical emission spectrometer

The calibration shall be performed according to the manufacturer's manual using the calibration solutions according to 7.8. The concentration of the calibration solutions shall be adjusted according to the sulfur concentration in the sample solutions. The concentration of the sample solution shall be in the (quasi-)linear range of the calibration curve. If necessary the analysis solution shall be diluted.

10.2 Ion chromatograph

The calibration shall be performed according to the manufacturer's manual. At least a two-point calibration with the calibration solutions according to 7.8 shall be carried out.

11 Performance

11.1 Determination of the blank value

The blank value shall be determined with an empty porcelain boat before the sample measurements. The same procedure as described in 11.2 shall be used. After a measurement series, the occurrence of memory effects shall be checked by performing an additional blank measurement.

NOTE If samples with high and low sulfur content (<50 mg/kg) have to be analysed, it is recommended to use separate sets of equipment.

11.2 Determination of the sulfur content

Two gas-washing bottles (6.3) are filled with 25 ml of absorption solution (7.6) each and connected to the outlet of the combustion device (6.1) (Annex A). The sample prepared according to Clause 8 is weighed into the porcelain boat (6.2) to the nearest 0,1 mg. Afterwards the porcelain boat (6.2) is inserted into the combustion device (6.1) and moved to the combustion zone. If there is a danger of vigorously reacting materials, e.g. for carbon materials, the porcelain boat (6.2) has to be shifted step by step into the combustion zone by moving the whole combustion tube.

NOTE 1 Another possibility to avoid a vigorous reaction is blending of the sample with an inert substance like aluminium oxide to distribute the heat to a larger volume.

NOTE 2 The sub-sample mass has to be adjusted by considering the sulfur content of the sample as well as the sensitivity and the linear range of ICP/OES and IC. Recommended values are:

- 10 g sub-sample mass for samples with a mass fraction of sulfur up to 500 mg/kg;
- 0,5 g sub-sample mass for samples with a mass fraction of sulfur from 500 mg/kg to 1 %;
- 0,5 g sub-sample mass and dilution of the sample solution to the factor of 10 for samples with a mass fraction of sulfur from 1 % to 10 %.

When the combustion is finished, which will be the case after approximately 30 min, the absorption solutions of both gas-washing bottles (6.3) were transferred to a 100 ml volumetric flask. Each gas-washing bottle is rinsed twice with 10 ml of water (7.5) into the volumetric flask. To degas the liquid in the volumetric flask, the solution is placed in the ultrasonic bath (6.6) for 5 min. Afterwards the volumetric flask is diluted with water (7.5) to volume.

The sulfur content of this solution is determined by ICP/OES and IC, respectively. For IC determination, the sample solution is filled in a disposable syringe (6.5) and passed through a filtration adaptor (6.4) before measurement. If the sulfur concentration of the sample solution is not within the calibration range, the sample solution has to be diluted accordingly.

In the case of calcium sulfate in the sample material, the residue in the porcelain boat (6.2) has to be boiled with 5 ml of hydrochloric acid (7.4). This extract is added to the absorption solution (7.6).

Measure the solution using ICP/OES.

Each sample has to be analysed at least two times. If the single values of the double-test deviate more than a given degree, depending on the repeatability of the method, then the analysis has to be repeated according to this Clause.

NOTE 3 The accuracy of the ICP/OES and IC analysis method can be checked using a certified reference material as the sample. See Annex F.

12 Calculation and report of the results

The sulfur content of the sample shall be calculated according to Equation (1) under consideration of sample mass and blank values. The sulfur content as a mean of the corrected single values of the

multiple determinations shall be expressed as mass fractions and rounded off in accordance with the uncertainty of measurement ([Annex E](#)).

$$w(S) = \frac{\beta(S) \cdot V}{m} \cdot F \quad (1)$$

where

- $w(S)$ is the mass fraction of sulfur in the sample, in milligrams per kilogram;
- $\beta(S)$ is the sulfur concentration of the sample solution, corrected with the blank value, in milligrams per litre;
- V is the volume of the sample solution, in litres;
- m is the mass of the dried sub-sample, in kilograms;
- F is the dilution factor of the sample solution.

13 Precision

13.1 Repeatability

The repeatability limit r will not be exceeded in more than 5 % of cases by the absolute difference between two single test results, determined in rapid succession by the same analyst with the same sample material using the same analytical procedure and the same equipment in the same laboratory.

NOTE The repeatability limit r depends on the examined material type and the determined mass of sulfur.

The precision data determined within a round-robin test are listed in [Annex D](#).

13.2 Reproducibility

The reproducibility R will not be exceeded in more than 5 % of cases by the absolute difference between two single test results, determined by different analysts with the same sample material using the same analytical procedure and different equipment in different laboratories.

NOTE The reproducibility R depends on the examined material type and the determined mass of sulfur.

The precision data determined within a round-robin test are listed in [Annex D](#).

14 Test report

Test reports shall include the following information

- a) sample identification;
- b) a reference to this part of ISO 14720;
- c) test results for the sulfur content, expressed as the mean of the single values of the multiple determinations;
- d) if required, uncertainty of the mean (see [Annex E](#)) or standard deviation;
- e) if required, information for calibration;
- f) any discrepancy of the procedure used for sample testing according to this part of ISO 14720;
- g) name and address of the laboratory, analysis date and, if required, signature of the responsible person.

Annex A (informative)

Example of a combustion device

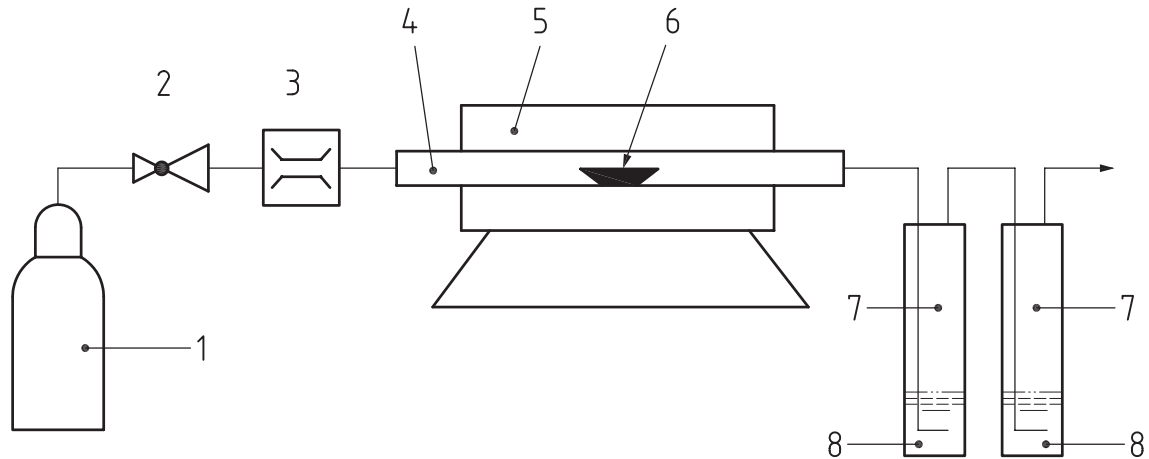

Key

- 1 Oxygen compressed gas cylinder
- 2 Pressure-reducing valve for the adjustment of 0 MPa to 1 MPa
- 3 Flow-measuring device, measuring range 0 l/h to 50 l/h
- 4 Combustion tube made out of fused silica with a grinding (inner diameter approx. 25 mm, length approx. 600 mm) and gas-tight inlet and outlet
- 5 Tube furnace, adjustable to $(1\ 100 \pm 20)^\circ\text{C}$, heating zone approx. 200 mm
- 6 Porcelain boat, unglazed
- 7 Gas-washing bottle, nominal volume 100 ml
- 8 Absorption solution, 25 ml

Figure A.1 — Example of a combustion device