**Ophthalmic instruments — Eye
refractometers**

Instruments ophtalmiques — Réfractomètres

iTeh STANDARD PREVIEW
(standards.iteh.ai)

ISO 10342:2010

<https://standards.iteh.ai/catalog/standards/sist/e7a17798-bc77-4f9e-97b4-7b2ccde56c8a/iso-10342-2010>



PDF disclaimer

This PDF file may contain embedded typefaces. In accordance with Adobe's licensing policy, this file may be printed or viewed but shall not be edited unless the typefaces which are embedded are licensed to and installed on the computer performing the editing. In downloading this file, parties accept therein the responsibility of not infringing Adobe's licensing policy. The ISO Central Secretariat accepts no liability in this area.

Adobe is a trademark of Adobe Systems Incorporated.

Details of the software products used to create this PDF file can be found in the General Info relative to the file; the PDF-creation parameters were optimized for printing. Every care has been taken to ensure that the file is suitable for use by ISO member bodies. In the unlikely event that a problem relating to it is found, please inform the Central Secretariat at the address given below.

iTeh STANDARD PREVIEW
(standards.iteh.ai)

ISO 10342:2010

<https://standards.iteh.ai/catalog/standards/sist/e7a17798-bc77-4f9e-97b4-7b2ccde56c8a/iso-10342-2010>



COPYRIGHT PROTECTED DOCUMENT

© ISO 2010

All rights reserved. Unless otherwise specified, no part of this publication may be reproduced or utilized in any form or by any means, electronic or mechanical, including photocopying and microfilm, without permission in writing from either ISO at the address below or ISO's member body in the country of the requester.

ISO copyright office
Case postale 56 • CH-1211 Geneva 20
Tel. + 41 22 749 01 11
Fax + 41 22 749 09 47
E-mail copyright@iso.org
Web www.iso.org

Published in Switzerland

Contents

Page

Foreword	iv
1 Scope	1
2 Normative references	1
3 Terms and definitions	1
4 Requirements	2
4.1 General	2
4.2 Optical requirements	2
4.3 Measuring range	2
4.4 Eyepiece (if applicable)	3
5 Test methods	3
5.1 General	3
5.2 Checking the vertex power	3
5.3 Checking the cylinder axis	3
6 Accompanying documents	3
7 Marking	4
Annex A (normative) Test device for eye refractometers	5

iTeh STANDARD PREVIEW
 (standards.iteh.ai)
 ISO 10342:2010
<https://standards.iteh.ai/catalog/standards/sist/e7a17798-bc77-4f9e-97b4-7b2ccde56c8a/iso-10342-2010>

Foreword

ISO (the International Organization for Standardization) is a worldwide federation of national standards bodies (ISO member bodies). The work of preparing International Standards is normally carried out through ISO technical committees. Each member body interested in a subject for which a technical committee has been established has the right to be represented on that committee. International organizations, governmental and non-governmental, in liaison with ISO, also take part in the work. ISO collaborates closely with the International Electrotechnical Commission (IEC) on all matters of electrotechnical standardization.

International Standards are drafted in accordance with the rules given in the ISO/IEC Directives, Part 2.

The main task of technical committees is to prepare International Standards. Draft International Standards adopted by the technical committees are circulated to the member bodies for voting. Publication as an International Standard requires approval by at least 75 % of the member bodies casting a vote.

Attention is drawn to the possibility that some of the elements of this document may be the subject of patent rights. ISO shall not be held responsible for identifying any or all such patent rights.

ISO 10342 was prepared by Technical Committee ISO/TC 172, *Optics and photonics*, Subcommittee SC 7, *Ophthalmic optics and instruments*.

This third edition cancels and replaces the second edition (ISO 10342:2003), which has undergone minor revision to clarify the scope and to update normative references, where applicable.

iTeh STANDARD PREVIEW
(standards.iteh.ai)
ISO 10342:2010
<https://standards.iteh.ai/catalog/standards/sist/e7a17798-bc77-4f9e-97b4-7b2ccde56c8a/iso-10342-2010>

Ophthalmic instruments — Eye refractometers

1 Scope

This International Standard, together with ISO 15004-1, specifies requirements and test methods for eye refractometers using an objective measuring principle. It is limited to the measurement of spherocylindrical refractive error.

This International Standard takes precedence over ISO 15004-1, if differences exist.

2 Normative references

The following referenced documents are indispensable for the application of this document. For dated references, only the edition cited applies. For undated references, the latest edition of the referenced document (including any amendments) applies.

ISO 7944, *Optics and optical instruments — Reference wavelengths*

ISO 8429, *Optics and optical instruments — Ophthalmology — Graduated dial scale*

ISO 13666, *Ophthalmic optics — Spectacle lenses — Vocabulary*

ISO 15004-1:2006, *Ophthalmic instruments — Fundamental requirements and test methods — Part 1: General requirements applicable to all ophthalmic instruments*

IEC 60601-1:2005, *Medical electrical equipment — Part 1: General requirements for basic safety and essential performance*

3 Terms and definitions

For the purposes of this document, the terms and definitions given in ISO 13666 as well as the following apply.

3.1

eye refractometer

instrument with continuous or digital readout used for measuring the refractive errors of the eye

3.2

tolerance

range of permissible difference between mean measured value and nominal value

4 Requirements

4.1 General

The eye refractometer shall conform to the general requirements specified in ISO 15004-1.

4.2 Optical requirements

The eye refractometer shall conform to the requirements given in Table 1 or Table 2.

The dioptric powers indicated in the requirements shall be referenced to the specific wavelengths used, $\lambda = 546,07 \text{ nm}$ or $\lambda = 587,56 \text{ nm}$ as required in ISO 7944.

The indication of the readings of cylinder power shall be possible in plus or minus cylinder convention.

Table 1 — Requirements for continuously indicating eye refractometers

Criterion	Measuring range	Maximum scale interval	Test device ^a	Tolerance
Spherical vertex power	−15 D to +15 D (maximum meridional vertex power)	0,25 D	0 D, ±5 D, ±10 D	±0,25 D
			±15 D	±0,50 D
Cylindrical vertex power	0 D to 6 D	0,25 D	Sphere: approx. 0 D Cylinder: −3 D Axis: 0°, 90°	±0,25 D
Cylinder axis ^b for cylinder power	0° to 180°	5°		±5°

^a The refractive error of the test device shall not differ by more than 1,0 D from the nominal value above.

^b Cylinder axis shall be indicated as specified in ISO 8429.

Table 2 — Requirements for digitally indicating eye refractometers

Criterion	Measuring range	Maximum scale interval	Test device ^a	Tolerance
Spherical vertex power	−15 D to +15 D (maximum meridional vertex power)	0,25 D	0 D, ±5 D, ±10 D	±0,25 D
			±15 D	±0,50 D
Cylindrical vertex power	0 D to 6 D	0,25 D	Sphere: approx. 0 D Cylinder: −3 D Axis: 0°, 90°	±0,25 D
Cylinder axis ^b for cylinder power	0° to 180°	1°		±5°

^a The refractive error of the test device shall not differ by more than 1,0 D from the nominal value above.

^b Cylinder axis shall be indicated as specified in ISO 8429.

4.3 Measuring range

The eye refractometer shall have a minimum measuring range for vertex power of −15 D to +15 D.

Eye refractometers that indicate cylindrical power shall have a minimum measuring range for cylinder power of 0 D to 6 D.

The eye refractometer shall have an axis direction range of 0° to 180°.

4.4 Eyepiece (if applicable)

The dioptric adjustment range of the operator's eyepiece shall be a minimum of -4 D to $+4$ D.

5 Test methods

5.1 General

All tests described in this International Standard are type tests.

Test results shall be evaluated according to the general rules of statistics.

5.2 Checking the vertex power

The vertex power accuracy requirements as specified in Tables 1 and 2 shall be verified using the special test device specified in Annex A.

Test measurements for spherical vertex power shall be made at least every 5 D over the claimed measuring range of the instrument, i.e. at -15 D, -10 D, -5 D, 0 D, $+5$ D, $+10$ D, $+15$ D.

Test measurements for cylindrical vertex power shall be made at 3 D.

5.3 Checking the cylinder axis

The astigmatic accuracy requirements, as specified in Tables 1 or 2, shall be verified using the special test device specified in Annex A. The orientation of the cylinder axis of the test device shall be known to within a tolerance of $\pm 1^\circ$.

Measurements shall be made in the two principal meridians. These two measurements shall give measurements for axis and power within the tolerances given in Tables 1 and 2.

6 Accompanying documents

The eye refractometer shall be accompanied by documents containing instructions for use and any necessary precautions.

In particular, this information shall contain:

- a) name and address of the manufacturer;
- b) instructions for effective disinfection of the eye refractometer with particular reference to instruments returned to the manufacturer for repair and maintenance;
- c) if appropriate, a statement that the eye refractometer in its original packaging conforms to the transport conditions as specified in 5.3 of ISO 15004-1:2006;
- d) any additional documents as specified in 7.9 of IEC 60601-1:2005;
- e) instructions for checking the calibration of the instrument.

7 Marking

The eye refractometer shall be permanently marked with at least the following information:

- a) name and address of manufacturer or supplier;
- b) name and model of eye refractometer;
- c) additional marking as required by IEC 60601-1;
- d) reference to this International Standard, i.e. ISO 10342:2010, if the manufacturer or supplier claims compliance with it;
- e) reference wavelength.

iTeh STANDARD PREVIEW
(standards.iteh.ai)

[ISO 10342:2010](https://standards.iteh.ai/catalog/standards/sist/e7a17798-bc77-4f9e-97b4-7b2ccde56c8a/iso-10342-2010)

<https://standards.iteh.ai/catalog/standards/sist/e7a17798-bc77-4f9e-97b4-7b2ccde56c8a/iso-10342-2010>

Annex A (normative)

Test device for eye refractometers

A.1 Design specifications

The test device shall be made of optical glass, with the Abbe number, ν , in the range 58 to 60, as shown in Figure A.1. The spherical front surface shall be polished to an optical finish and the plano back surface should be lightly frosted. All other surface shall be clear but may be roughly finished.

For testing the spherical vertex power accuracy of the eye refractometer, the test device shall be used as shown in Figure A.1 a) or b). If the eye refractometer does not provide an artificial pupil, type a) with a pupil diameter between 3 mm and 4 mm should be used.

For testing the cylinder axis and cylinder power accuracy, the device with front toric surface shall be used. If cylinder power/axis is tested by adding a cylindrical lens to the spherical test device, a thin rigid toric lens with an 8 mm base curve may be fixed on to the front surface of the device. The orientation of the cylinder axis shall be marked so that the device may be oriented in use. When the test device is modified in this fashion, it can only be used to measure the astigmatic difference and the axis direction.

The test device shall be placed in a suitable holder and attached to the eye refractometer so that its optical axis is parallel to that of the eye refractometer to a tolerance of $\pm 1^\circ$.

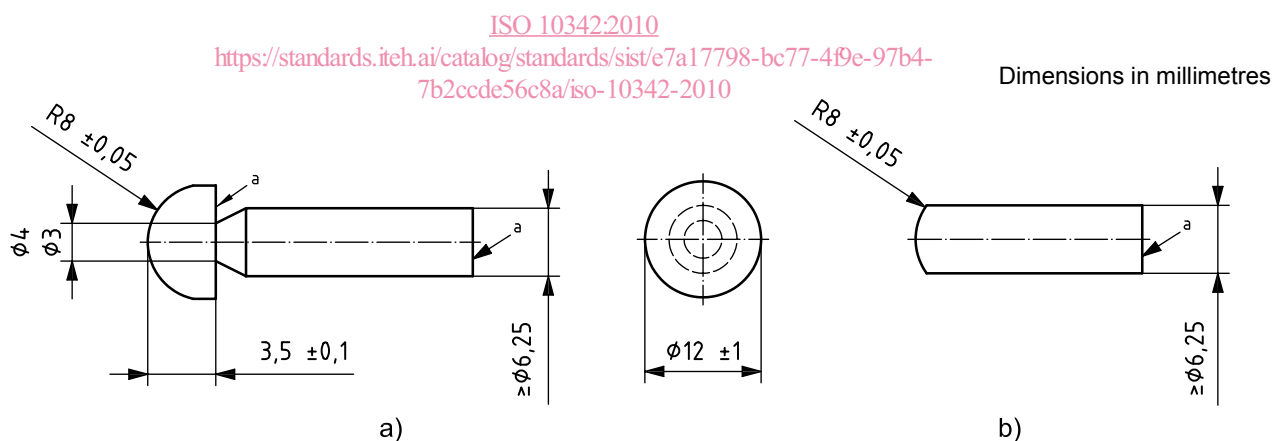

a Painted dark grey.

NOTE The reflection rates of painted fundus of model eye should be similar to that of the human fundus.

Figure A.1 — Test device

A.2 Accuracy of refractive power

The refractive power of the test devices used to verify the spherical vertex power of eye refractometers shall be known to $\pm 0,06$ D. The wavelength used for the calculation and the vertex distance shall be specified.