

---

---

**Forestry machinery — Portable chain-  
saws — Kickback test**

*Matériel forestier — Scies à chaîne portatives — Essai de rebond*

**iTeh STANDARD PREVIEW**  
**(standards.iteh.ai)**

[ISO 9518:2018](https://standards.iteh.ai/catalog/standards/sist/eafd070d-78f0-4fe0-a997-93ced0c304ff/iso-9518-2018)

<https://standards.iteh.ai/catalog/standards/sist/eafd070d-78f0-4fe0-a997-93ced0c304ff/iso-9518-2018>



**iTeh STANDARD PREVIEW**  
**(standards.iteh.ai)**

ISO 9518:2018

<https://standards.iteh.ai/catalog/standards/sist/eafd070d-78f0-4fe0-a997-93ced0c304ff/iso-9518-2018>



**COPYRIGHT PROTECTED DOCUMENT**

© ISO 2018

All rights reserved. Unless otherwise specified, or required in the context of its implementation, no part of this publication may be reproduced or utilized otherwise in any form or by any means, electronic or mechanical, including photocopying, or posting on the internet or an intranet, without prior written permission. Permission can be requested from either ISO at the address below or ISO's member body in the country of the requester.

ISO copyright office  
CP 401 • Ch. de Blandonnet 8  
CH-1214 Vernier, Geneva  
Phone: +41 22 749 01 11  
Fax: +41 22 749 09 47  
Email: [copyright@iso.org](mailto:copyright@iso.org)  
Website: [www.iso.org](http://www.iso.org)

Published in Switzerland

# Contents

	Page
<b>Foreword</b> .....	<b>v</b>
<b>1 Scope</b> .....	<b>1</b>
<b>2 Normative references</b> .....	<b>1</b>
<b>3 Terms and definitions</b> .....	<b>1</b>
<b>4 Test method</b> .....	<b>2</b>
4.1 Principles.....	2
4.2 Chain-saw configuration.....	2
4.2.1 General.....	2
4.2.2 Chain-saw families.....	3
4.2.3 Requirements for testing bars and saw-chains.....	3
4.3 Equipment and materials to determine CKA.....	3
4.4 Preparation.....	3
4.4.1 General.....	3
4.4.2 Physical measurements of chain-saw .....	4
4.4.3 Dimensional measurements.....	4
4.4.4 Chain-saw and saw-chain preparation .....	5
4.4.5 Kickback machine preparation .....	7
4.4.6 Chain-saw installation and alignment.....	7
4.4.7 Balance saw/clamp/cradle assembly.....	7
4.4.8 Horizontal friction measurements .....	8
4.4.9 Rotary friction measurements .....	9
4.4.10 Horizontal & rotary restraining systems alignment .....	10
4.4.11 Impact velocity adjustment.....	12
4.5 Test requirements and procedures.....	13
4.5.1 Test requirements.....	13
4.5.2 Kickback testing procedure.....	15
4.5.3 Kickback energy determination.....	15
4.5.4 Termination of test sequence.....	16
4.5.5 Chain brake energy determination.....	16
4.5.6 Chain brake actuation angle measurement .....	20
4.5.7 Chain brake stopping time measurement .....	21
4.6 Kickback angle computation.....	21
4.6.1 General.....	21
4.6.2 Input data .....	21
4.6.3 Computation and results.....	22
<b>5 Test report</b> .....	<b>22</b>
<b>Annex A (normative) Computer program flowchart</b> .....	<b>23</b>
<b>Annex B (normative) Procedure for hardness testing of Medium Density Fibreboard (MDF)</b> .....	<b>34</b>
<b>Annex C (informative) Test record</b> .....	<b>36</b>
<b>Annex D (informative) Chain-saw centre of gravity and inertia measurement</b> .....	<b>39</b>
<b>Annex E (informative) Computer program checkout models</b> .....	<b>45</b>
<b>Bibliography</b> .....	<b>53</b>

## Foreword

ISO (the International Organization for Standardization) is a worldwide federation of national standards bodies (ISO member bodies). The work of preparing International Standards is normally carried out through ISO technical committees. Each member body interested in a subject for which a technical committee has been established has the right to be represented on that committee. International organizations, governmental and non-governmental, in liaison with ISO, also take part in the work. ISO collaborates closely with the International Electrotechnical Commission (IEC) on all matters of electrotechnical standardization.

The procedures used to develop this document and those intended for its further maintenance are described in the ISO/IEC Directives, Part 1. In particular the different approval criteria needed for the different types of ISO documents should be noted. This document was drafted in accordance with the editorial rules of the ISO/IEC Directives, Part 2 (see [www.iso.org/directives](http://www.iso.org/directives)).

Attention is drawn to the possibility that some of the elements of this document may be the subject of patent rights. ISO shall not be held responsible for identifying any or all such patent rights. Details of any patent rights identified during the development of the document will be in the Introduction and/or on the ISO list of patent declarations received (see [www.iso.org/patents](http://www.iso.org/patents)).

Any trade name used in this document is information given for the convenience of users and does not constitute an endorsement.

For an explanation on the voluntary nature of standards, the meaning of ISO specific terms and expressions related to conformity assessment, as well as information about ISO's adherence to the World Trade Organization (WTO) principles in the Technical Barriers to Trade (TBT) see the following URL: [www.iso.org/iso/foreword.html](http://www.iso.org/iso/foreword.html). (standards.iteh.ai)

This document was prepared by Technical Committee ISO/TC 23, *Tractors and machinery for agriculture and forestry*, Subcommittee SC 17, *Manually portable forest machinery*.

This third edition cancels and replaces the second edition (ISO 9518:1998), which has been technically revised

Besides editorial corrections the following changes have been made to the previous edition of this document:

- Scope: inclusion of electric-powered chain-saws;
- [3](#) Terms and definitions: reference to ISO 6531 added and definitions updated;
- [4.3.6](#) Test specimens: hardness requirement for MDF test specimens added;
- [4.4.5](#) Kickback machine preparation: weight of standard and lightweight carriage defined;
- [4.4.8](#) Horizontal friction measurements: Horizontal friction test methods added;
- [4.4.9](#) Rotary friction measurements: Rotary friction test methods added;
- [4.4.10](#) Horizontal and rotary restraining systems alignment: Restraining systems adjustments specified more precisely;
- [Annex B](#) [Procedure for hardness testing of Medium Density Fibreboard (MDF)] has been added;
- [Annex D](#) (Chain-saw centre of gravity and inertia measurement) revised.

# Forestry machinery — Portable chain-saws — Kickback test

## 1 Scope

This document specifies the methodology for determining the kickback potential of gasoline-powered and electric-powered (including battery powered) chain-saws, complete with guide bar and saw-chain.

This document has been demonstrated to be an accurate method of measurement for evaluating computed kickback angles and energy associated with chain-saw kickback for electric-powered chain-saws (including battery powered) and gasoline-powered chain-saws with engine capacity up to 80 cm<sup>3</sup>. It is not intended to evaluate chain-saws with an engine capacity of above 80 cm<sup>3</sup>. Furthermore, because of physical size limitations of the kickback machine, it is not intended for testing of units with guide bar cutting length in excess of 63 cm.

Modifications to the methodology for determining the kickback potential introduced in this edition are aimed to have a better reproducibility of the results; test results obtained according to the previous methodology still maintain their validity.

## 2 Normative references

The following documents are referred to in the text in such a way that some or all of their content constitutes requirements of this document. For dated references, only the edition cited applies. For undated references, the latest edition of the referenced document (including any amendments) applies.

ISO 6531, *Machinery for forestry — Portable chain-saws — Vocabulary*

ISO 6535, *Portable chain-saws — Chain brake performance*

## 3 Terms and definitions

For the purposes of this document, the terms and definitions given in ISO 6531 and the following apply.

ISO and IEC maintain terminological databases for use in standardization at the following addresses:

- ISO Online browsing platform: available at <https://www.iso.org/obp>
- IEC Electropedia: available at <http://www.electropedia.org/>

### 3.1

#### bar nose radius

continuous radius formed on the top portion of the bar from the centreline of the bar to an angle 35° above the centreline

Note 1 to entry: See [Figure 1](#).

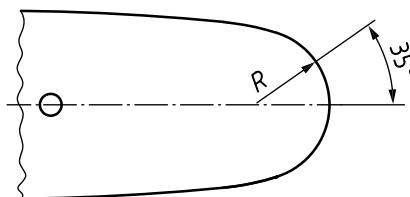

Figure 1 — Bar nose radius

3.2

**manually activated chain brake**

chain brake which is intended to be actuated by the hand of the operator

3.3

**contact angle**

angle between the surface of the test specimen and a perpendicular to the guide bar centre line

3.4

**data set**

group of data points, all taken at the same test conditions

3.5

**horizontal system**

portion of the kickback machine used to measure the horizontal (linear) energy of the kickback reaction

3.6

**impact**

test sequence involving releasing the test specimen at a specified speed into contact with the moving saw-chain at the guide bar tip to create a simulated kickback reaction

3.7

**rotary system**

portion of the kickback machine used to measure the rotary energy of the kickback reaction

3.8

**specimen**

**test specimen**

block of medium density fibreboard used as an object for the saw-chain to engage in a simulated kickback

iTeh STANDARD PREVIEW  
(standards.iteh.ai)

ISO 9518:2018

<https://standards.iteh.ai/catalog/standards/sist/eafd070d-78fd-4fe0-a997-93ced0c304ff/iso-9518-2018>

**4 Test method**

**4.1 Principles**

The flat surface of the test specimen (MDF) is thrust into contact with the moving saw-chain at the tip of a chain-saw guide bar at a specified speed in order to produce a simulated kickback reaction. This takes place under controlled conditions in the kickback machine, which is designed to measure the magnitude of rotary and horizontal energies generated during the resulting kickback reaction.

A step-by-step search, covering a range of critical test conditions, determines the peak energy values to be used in calculating the computed kickback angle(s) CKA using the analytical model. This peak value is intended to simulate the most severe conditions reasonably expected to be encountered by typical users.

Since there may be some variability, several impacts are made under each set of conditions and the results averaged.

NOTE Test parameters such as approach speed, engine speed, shape and type of test materials have been established to permit consistent evaluation of a wide range of cutting attachment and type of power heads and to simulate kickback situations found in actual practice.

**4.2 Chain-saw configuration**

**4.2.1 General**

The worst-case configuration (e.g., saw-chain with the highest kickback magnitude) can be demonstrated on a chain-saw with cutting attachments of the same class and pitch.

#### 4.2.2 Chain-saw families

For the purposes of chain-saw qualification, saws that have an engine displacement within 20 % and similar mass distribution (having centre of gravity coordinates within  $\pm 5$  mm, a mass tolerance of  $\pm 0,2$  kg, and a polar moment of inertia [PMI] tolerance of  $\pm 10$  %) shall be regarded as being equivalent to one another. However, if a saw family within this range is to be qualified, at least the largest displacement saw shall be tested.

#### 4.2.3 Requirements for testing bars and saw-chains

A guide bar with the largest bar nose radius and/or the greatest number of sprocket teeth represents the highest energy configuration and covers all other bars of the same length with a smaller radius. Tests need not be repeated for saw-chains that have been documented to have lower kickback potential than the highest kickback energy saw-chain on equivalent types of chain-saws.

At a minimum, testing shall be performed with the largest bar nose radius of the manufacturer's designated standard guide bars recommended for sale to the end-user. If multiple bar lengths are listed in the operator's manual, the longest, shortest, and one other length shall be tested. If the kickback test results for each of these lengths are less than 35° CKA, all other lengths shall be accepted. If any guide bar exceeds 35° CKA, all bar lengths shall be tested.

### 4.3 Equipment and materials to determine CKA

4.3.1 **Computer program**, as specified in [Annex A](#), to compute the kickback angle using measured inputs.

4.3.2 **Chain-saw kickback test machine for energy level measurements.**

4.3.3 **Engine speed indicator** with an accuracy of  $\pm 1,5$  % of the measured value.

4.3.4 **Carriage-velocity timing device**, including probes with an accuracy of  $\pm 1$  ms.

4.3.5 **Timer control switch box.**

4.3.6 **Test specimens**, consisting of medium-density fibreboard (MDF) samples, 38 mm  $\times$  38 mm  $\times$  250 mm or 38 mm  $\times$  76 mm  $\times$  250 mm. The samples shall be oriented with the rough side (end grain) facing the bar tip. The density range shall be  $737 \text{ kg/m}^3 \pm 32 \text{ kg/m}^3$ . The samples shall have a hardness of  $2\,892 \text{ N} \pm 667 \text{ N}$  (the method for determining fibreboard hardness is specified in [Annex B](#)).

4.3.7 **Chain-brake actuating apparatus** (for complete chain-saw tests only).

NOTE The bill of materials and engineering drawings describing a kickback test machine, the kickback calculation program, and a manual entitled "Chain-saw Kickback Test Machine - Principles of Operation" are available on request from the Outdoor Power Equipment Institute, 341 S Patrick St, Alexandria, VA 22314, USA.

### 4.4 Preparation

#### 4.4.1 General

Record all measurements on the kickback test record (see Figures C.1 and C.2).

4.4.2 Physical measurements of chain-saw

4.4.2.1 Prior to taking measurements prepare the chain-saw and saw-chain in accordance with 4.4.4. The physical measurements listed in 4.4.2.2 to 4.4.2.4 shall be made with the guide bar and saw-chain attached in proper working position and with oil and fuel tanks full.

4.4.2.2 Measure the chain-saw mass in kilograms. An accuracy of  $\pm 50$  g is acceptable for this measurement.

4.4.2.3 Determine the location of axis of rotation, through the centre of gravity, perpendicular to the plane of the guide bar. It is to be marked on the saw body. An accuracy of  $\pm 6$  mm is acceptable for this measurement.

4.4.2.4 Determine the chain-saw polar moment of inertia (PMI) about an axis through the centre of gravity and perpendicular to the plane of the guide bar, in kilograms metre squared. A procedure for determining the polar moment of inertia is presented in Annex D.

4.4.3 Dimensional measurements

4.4.3.1 The bar tip and handle coordinates shall be measured in millimetres to an accuracy of  $\pm 3$  mm as follows: (see Figure 2).

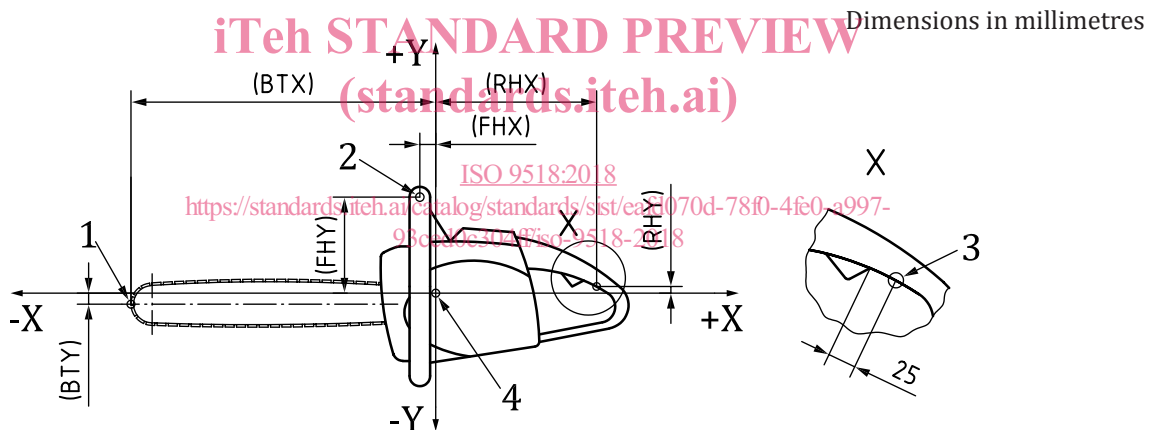

Key

- 1 bar tip coordinates
- 2 front handle coordinates
- 3 rear handle coordinates
- 4 centre of gravity

Bar tip coordinates (BTX, BTY) are with the chain adjusted so that maximum X dimension is obtained. Measure to the tip of the chain on the guide bar located along the projected centreline of the guide bar. For asymmetrical bars, it is located along a line through the centre of the upper quadrant nose radius and parallel to the guide bar centreline. Front handle coordinates (FHX, FHY) are measured to the centre of the front handle bar. If the handle is angled in any plane or direction, use the midpoint of the grip area.

Rear handle coordinates (RHX, RHY) are measured 25 mm behind the rear edge of the throttle trigger on the underside of the handle surface.

Observe the sign convention carefully.

The Centreline of guide bar shall be horizontal.

Measure the chain-saw bar tip and handle locations from the centre of gravity.

Figure 2 — Coordinate measurements



**4.4.3.2** The chain-saw shall be positioned on a level surface so that the centreline of the guide bar is level. The guide bar tip, Point B, shall be located at the intersection of a horizontal line through the nose radius with the outermost element of the saw-chain. This measurement shall be made with the chain adjusted such that the maximum X dimension is obtained to the tip of the chain on the guide bar. Measure and record BTX, the horizontal displacement from the centre of gravity to Point B. Measure and record BTY, the vertical displacement from the centre of gravity to Point B.

For non-symmetrical bars, Point B will not lie on the centreline of the guide bar. The saw-chain shall be rotated to the greatest horizontal displacement.

**4.4.3.3** On the front handle, Point F shall be located at the centre of the front handle, at the midpoint of the hand-grip segment. Measure and record FHX, the horizontal displacement from the centre of gravity to Point F. Measure and record FHY, the vertical displacement from the centre of gravity to Point F.

If the handle is angled in any plane or direction, use the midpoint of the grip area.

**4.4.3.4** On the rear handle, Point R shall be located by determining the intersection of a 25 mm radius arc with the lower portion of the rear handle. (The arc shall originate at the lowest point where the throttle control trigger of the chain-saw intersects the saw casing.) Measure and record RHX, the horizontal displacement from the centre of gravity to Point R. Measure and record RHY, the vertical displacement from the centre of gravity to Point R.

#### 4.4.4 Chain-saw and saw-chain preparation

**4.4.4.1** The chain-saw and saw-chain shall be prepared for testing using the following procedure.

**4.4.4.2** The saw-chain shall be new.

**4.4.4.3** Saw-chain tension shall be set to provide a maximum clearance between the chain and the bar of 0,017 mm per mm of the bar length, in accordance with Figure 3. The chain should move freely on the bar with moderate hand pressure.

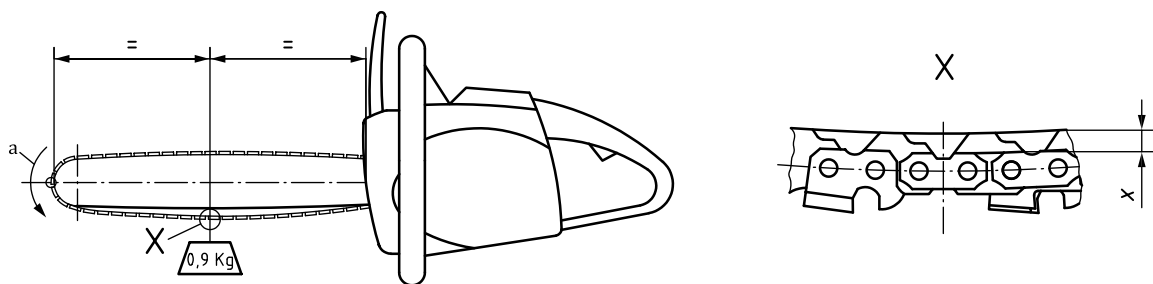

#### Key

- x maximum 0,017 x rated bar cutting capacity
- a Rotate chain to the tightest condition.

**Figure 3 — Saw-chain tension adjustment**

**4.4.4.4** The chain-saw shall be in functionally new condition.

**4.4.4.5** The chain-saw shall be run-in according to the manufacturer's recommendations.

**4.4.4.6** If the saw is equipped with a removable bar tip guard, remove the bar tip guard for testing.

4.4.4.7 If the saw is equipped with a chain brake, disable the mechanism if necessary to prevent activation. The chain brake may be rendered inoperative by physically blocking the brake mechanism against operation or by tying the chain brake lever to the front handle.

4.4.4.8 Remove the front handle grip cover (if any) in the area where the saw handle clamp will be attached and construct a clamp insert to fit the saw handle. Attach the saw handle clamp to the front handle and the cradle so that the longitudinal axis of the guide bar is level and parallel to the longitudinal axis of the kickback machine as nearly as possible and the guide bar plane is in a vertical position (see [Figure 4](#)). Tighten securely.

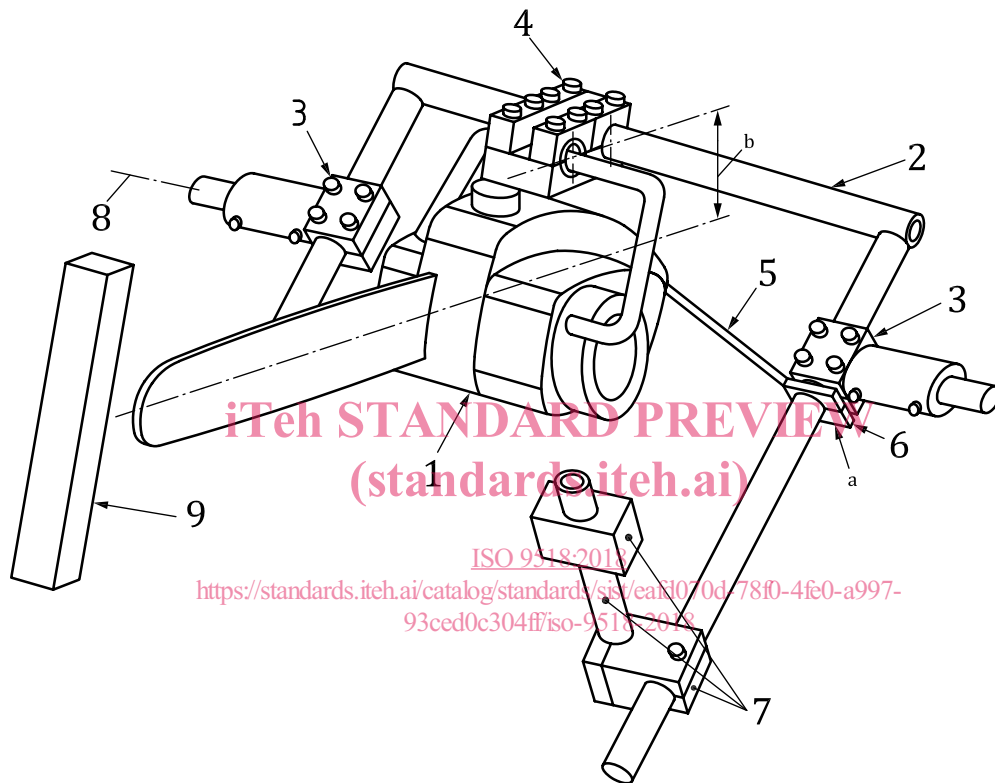

**Key**

- 1 chain-saw
- 2 cradle
- 3 support block
- 4 clamp
- 5 brace assembly
- 6 brace
- 7 balancing weights
- 8 kickback machine rotary axis
- 9 MDF specimen
- a One brace preferred, second brace optional; brace to be attached as close to support blocks as possible.
- b Clamp centreline parallel to guide bar centreline.

**Figure 4 — Installation of saw/clamp/cradle assembly**

Under some test conditions, the front handle may become distorted, making testing difficult and subject to error. Substitution of a stronger, fabricated handle is permitted, so long as location of the centre of the mounting clamp is substantially unchanged from the original handle. Weight increase is to

be minimized, and in no instance is total added weight to exceed 5 % of the empty saw weight. Adjust the chain-saw CG location, balance and mass of carriage matching weight accordingly, but unmodified chain-saw mass and PMI shall be used for computer calculations of CKA.

For electric chain-saws, the mass, centre of gravity, and polar moment of inertia measurements shall be made with no extension cord plugged into the saw. The length of power cord protruding from the saw shall be positioned over the rear handle and taped or tied in position. For purposes of this test, the maximum length of power cord supplied with the electric saw should be 300 mm.

**4.4.4.9** Attach the cradle to the saw clamp assembly. Do not tighten bolts to the cradle assembly.

#### **4.4.5 Kickback machine preparation**

**4.4.5.1** Before installing the chain-saw and cradle into the kickback machine, prepare the kickback test machine as follows.

**4.4.5.2** If the chain-saw mass (see [4.4.2.2](#)) is less than the standard carriage (3,8 kg), the standard carriage may be replaced with the lightweight carriage (2,2 kg).

**4.4.5.3** Insert a fibreboard test specimen in the carriage clamp. The specimen shall be oriented with the rough side (end grain) facing the guide bar tip.

**4.4.5.4** If necessary, add mass to the carriage until the carriage mass (including fibreboard test specimen and any clamps, if used) equals the mass of the saw  $\pm 100$  g.

#### **4.4.6 Chain-saw installation and alignment**

**4.4.6.1** The chain-saw and cradle assembly shall be installed and aligned into the kickback test machine with the following procedure.

**4.4.6.2** Install the saw/clamp/cradle assembly in the kickback machine in accordance with [Figure 4](#), and align the guide bar with the centreline of the fibreboard specimen.

**4.4.6.3** Adjust the chain-saw, clamp and cradle in the kickback machine so that the centre of gravity of the saw is aligned to within  $\pm 3$  mm of the rotary axis. Make this adjustment by rotating the saw/clamp/assembly where it attaches to the cradle and by sliding the cradle in the support blocks.

Do not rotate the clamp where it attaches to the saw handle, this was adjusted in [4.4.4.8](#).

**4.4.6.4** Attach a brace assembly between the chain-saw rear handle and either leg of the cradle as nearly as possible to the rotary axis, and with mass of brace centred as nearly as possible about the rotary axis. A second brace may be installed if needed to maintain saw position during testing.

**4.4.6.5** Securely tighten all assembly fasteners.

The mass and position of brace assembly can affect test results. The mass of the brace assembly shall not exceed 0,4 kg.

For electric saws, the cord shall be secured and routed from the front handle so as to closely follow the axis of rotation in such a manner that the cord shall not impede the free rotation of the chain-saw.

#### **4.4.7 Balance saw/clamp/cradle assembly**

**4.4.7.1** The system shall be balanced using the minimum amount of mass located as close to the rotary axis as possible (see [Figure 4](#)).

**4.4.7.2** Fuel and oil tanks shall be full.

NOTE External fuel and oil supplies to maintain full tanks are acceptable.

**4.4.7.3** Acceptable initial balance is achieved when the saw/clamp/cradle assembly will not rotate at the “horizontal” or “vertical” positions or when a 60 g mass hung from the rotary pulley will counter any observed rotation. If the centre of gravity of the saw shifts due to soft vibration isolators, a compromise between the horizontal and vertical positions is permissible.

For convenience, a record of the position of balancing weights and external braces may be kept on a form such as that shown in Figure C.2.

**4.4.8 Horizontal friction measurements**

**4.4.8.1 General**

Horizontal friction shall be measured prior to and after kickback energy tests. Measurements shall be made with the ratchet pawl in its activated position. Pulleys for restraining the weight system shall spin freely. The average of the horizontal friction measurements in the direction of travel away from the powerhead shall not exceed 2,2 N.

**4.4.8.2 Carriage bearing alignment**

If necessary to meet the maximum tolerance for horizontal friction, the carriage bearings may be aligned using the following procedure.

- a) One bearing shall be adjusted with the other one loose. After adjustment, the position of the adjusting screw shall be noted when the first bearing is aligned.
- b) The first bearing shall be loosened and then the second bearing shall be adjusted. When loose, each bearing shall be tightened until it begins to grip the shaft. The tightening shall be stopped just before an increase in the force required to move the bearing is felt.
- c) The first bearing shall be returned to its proper setting.

**4.4.8.3 Horizontal friction test**

**4.4.8.3.1 General**

To determine the horizontal friction one of the following test methods A or B shall be used.

**4.4.8.3.2 Horizontal friction test method A**

- a) Weights shall be attached to the carriage, with the MDF specimen installed, to equal, within 100 g of the mass of the chain-saw.
- b) The friction measurement weight cup shall be connected to the carriage.
- c) Sufficient mass shall be added to the cup assembly to cause the carriage to move at least 0,3 m (with the ratchet in place). Record the weight of the cup and the amount of added mass needed.
- d) When the mass required to move the carriage exceeds 0,23 kg, the bearings shall be cleaned and the machine shall be adjusted as required.
- e) Horizontal friction,  $f_h$ , shall then be computed as follows:

$$f_h = m_1 + m_2$$

where

$m_1$  is the mass of cup assembly, expressed in kilograms;

$m_2$  is the added mass, expressed in kilograms.

#### 4.4.8.3.3 Horizontal friction test method B

- a) A 0,23 kg mass and cable assembly shall be attached to the carriage.
- b) When the mass causes the carriage to travel at least 0,3 m, with ratchets in place, the friction level shall be within tolerance.
- c) The horizontal system shall be cleaned and adjusted to reduce the friction level if necessary.
- d) Horizontal kickback energies shall be computed with a frictional level of 2,2 N.

#### 4.4.9 Rotary friction measurements

##### 4.4.9.1 General

Rotary friction shall be measured prior to and after kickback energy tests. Measurements shall be made with the ratchet pawl in its activated position. Pulleys for restraining the weight system shall spin freely. The average of the rotary friction measurements shall not exceed 2,2 N.

In saws with soft isolator systems, the centre of gravity shifts as the saw and cradle rotate. If shifting of the centre of gravity of the saw prevents accurate friction measurements, a substitute saw of about the same mass may be used for friction measurements.

##### 4.4.9.2 Rotary bearing alignment

If necessary to meet the maximum tolerance for rotary friction, the rotary bearings may be aligned and adjusted using the following procedure.

- a) The rotary machine parts shall be removed and an alignment shaft placed through the rotary bearings.
- b) The alignment shaft shall be levelled.
- c) The pillow blocks and bearing plates shall be adjusted so that the shaft passes easily through the bearings and rotates freely.

##### 4.4.9.3 Rotary friction test

###### 4.4.9.3.1 General

To determine the rotary friction one of the following test methods A or B shall be used.

###### 4.4.9.3.2 Rotary friction test method A

- a) The friction-measurement weight cup shall be attached to the rotary pulley with the cradle legs horizontal.
- b) Sufficient mass shall be added to the weight cup to cause a saw rotation of at least 180°, with ratchet pawls in place.
- c) When the mass required to move the rotary system exceeds 0,23 kg, the bearings shall be cleaned and adjusted to bring the friction level within tolerance.
- d) Rotary axis friction,  $f_r$ , shall then be computed as follows:

$$f_r = m_1 + m_2$$

where

$m_1$  is the mass of cup assembly, expressed in kilograms;

$m_2$  is the added mass, expressed in kilograms.

#### 4.4.9.3.3 Rotary friction test method B

- a) A 0,23 kg mass and cable assembly shall be attached to the rotary pulley, with the ratchet pawls in place.
- b) When the 0,23 kg mass causes the saw cradle assembly to rotate from the horizontal (0°) through at least 180°, the friction level shall be within tolerance.
- c) In rotary kickback energy computations, a 2,2 N rotary friction shall be used.

#### 4.4.10 Horizontal & rotary restraining systems alignment

**4.4.10.1** The specimen contact angle shall be set to 30°. Position the carriage so that the test specimen contacts the saw-chain. Adjust the position of the rack/horizontal restraining assembly so that the cable from the carriage to the pulley is vertical with the carriage positioned from 25 mm to 75 mm to the right of the point at which the weight will lift (see [Figure 5](#)). (The horizontal restraining weight will just swing free with the carriage pointer at "0".)

ITEH STANDARD PREVIEW  
(standards.iteh.ai)

[ISO 9518:2018](#)

<https://standards.iteh.ai/catalog/standards/sist/eafd070d-78f0-4fe0-a997-93ced0c304ff/iso-9518-2018>

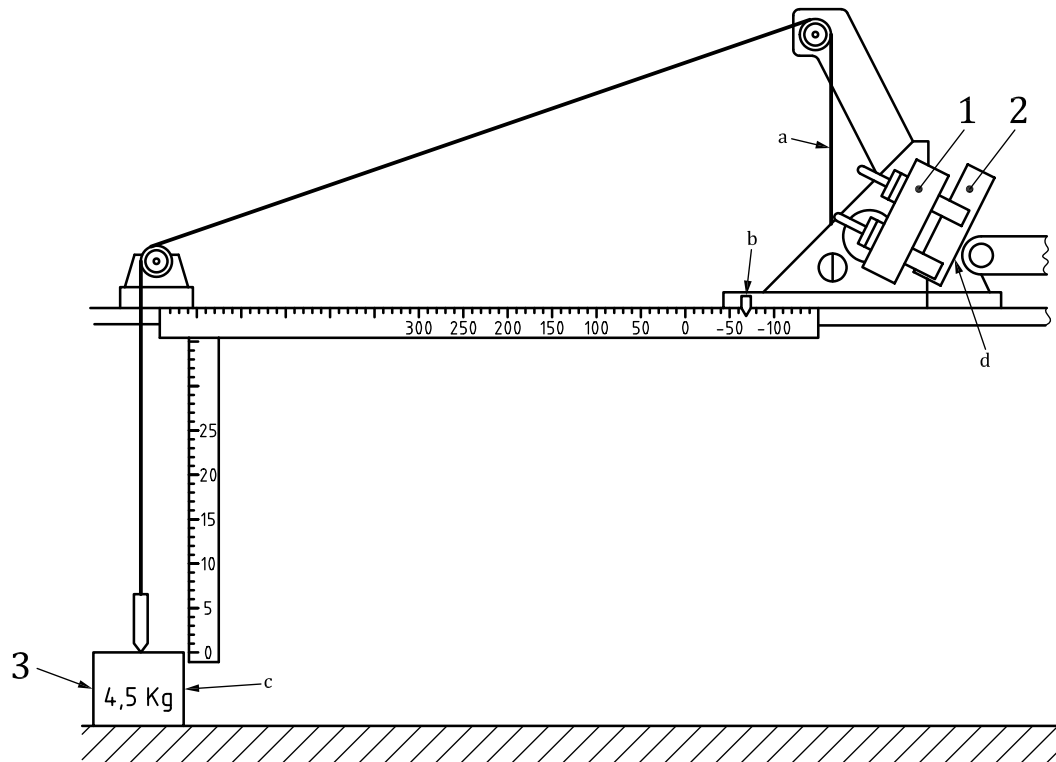
**Key**

- 1 MDF carriage  
 2 MDF specimen  
 3 restraining weight  
 a This section of cable is vertical.  
 b The MDF carriage is 25 mm to 75 mm to the right of the point at which the weight will lift.  
 c The restraining weight will just swing free with the carriage pointer at "0". (A larger weight shall be used only if necessary.).  
 d The specimen contact angle is 30°.

**Figure 5 — Adjustment of rack/horizontal restraining system**