INTERNATIONAL STANDARD



1039

INTERNATIONAL ORGANIZATION FOR STANDARDIZATION • МЕЖДУНАРОДНАЯ ОРГАНИЗАЦИЯ ПО СТАНДАРТИЗАЦИИ • ORGANISATION INTERNATIONALE DE NORMALISATION

Cinematography — Cores for motion-picture and magnetic film rolls — Dimensions

Cinématographie — Noyaux pour bobines de films cinématographiques et magnétiques — Dimensions

First edition — 1975-05-01

iTeh STANDARD PREVIEW
(standards.iteh.ai)

[ISO 1039:1975](#)

<https://standards.iteh.ai/catalog/standards/sist/8aefedea-3467-4cf4-a824-99aa8f98aaa4/iso-1039-1975>

UDC 778.533.4

Ref. No. ISO 1039-1975 (E)

Descriptors : cinematography, motion-picture film, bobbins, cores.

Price based on 4 pages

FOREWORD

ISO (the International Organization for Standardization) is a worldwide federation of national standards institutes (ISO Member Bodies). The work of developing International Standards is carried out through ISO Technical Committees. Every Member Body interested in a subject for which a Technical Committee has been set up has the right to be represented on that Committee. International organizations, governmental and non-governmental, in liaison with ISO, also take part in the work.

Draft International Standards adopted by the Technical Committees are circulated to the Member Bodies for approval before their acceptance as International Standards by the ISO Council.

International Standard 1039 was drawn up by Technical Committee ISO/TC 36, *Cinematography*. It was submitted directly to the ISO Council, in accordance with clause 6.12.1 of the Directives for the technical work of ISO.

This International Standard cancels and replaces ISO Recommendation R 1039-1969, which had been approved by the Member Bodies of the following countries :

Belgium	France	Korea, Rep. of
Brazil	Germany	Netherlands
Bulgaria	Greece	Romania
Canada	Hungary	Sweden
Chile	Israel	Switzerland
Czechoslovakia	Italy	United Kingdom
Egypt, Arab Rep. of	Japan	U.S.A.

No Member Body had disapproved the Recommendation.

Cinematography — Cores for motion-picture and magnetic film rolls — Dimensions

iTeh STANDARD PREVIEW (standards.iteh.ai)

1 SCOPE AND FIELD OF APPLICATION

This International Standard specifies the sizes and dimensions of cores for motion-picture and magnetic film rolls.

NOTES

1 Inch system dimensions shown in clauses 2, 3 and 4 have been rounded to show acceptable inch system practice. In a few such cases, particularly in clause 4, the rounding *direction* differs from customary rules applied in converting millimetres to inches.

2 The direction and magnitude of the difference between dimension *A* values in clause 2 and the *nominal* width of the cores has been fixed intentionally to encourage a common manufacturing practice of keeping the maximum widths of cores very slightly less than the minimum widths of corresponding films.

3 For dimension *B* of the 16 mm × 100 mm and 35 mm × 75 mm simple core sizes, countries using the inch system have worked to some round inch nominal values,

4.00 (± 0.02) in and $3.00 \left(\begin{smallmatrix} +0.12 \\ -0.02 \end{smallmatrix} \right)$ in respectively, which are significantly different from the round nominal millimetre figures used by metric system countries. In the case of the 35 mm × 75 mm core size, some manufacturers have preferred a dimension even larger than a nominal 3 in value. The *B* dimension has not been critical in the past and no conflicts are known with respect to interchangeability in equipment. Nevertheless, the millimetre or

inch equivalent values shown in the table for dimension *B* should be observed as tools and dies are replaced, although the existing inch system values are recognized temporarily as acceptable.

4 It is recognized that a 70 mm × 50 mm size simple core exists with dimensions as shown in figure 1 and with *A* and *B* dimensions of $69,9 \pm 1,0$ mm ($2,75 \pm 0,04$ in) and $50,0 \pm 0,5$ mm ($1,97 \pm 0,02$ in) respectively. This core has not been included in clause 2 in order to encourage its replacement in practice with a simple core of 70 mm × 75 mm size. The latter represents a better engineering design for the weights of film usually involved.

5 Attention is drawn to the fact that some cores exist with a bore-plus-keyway dimension of 29,2 mm (1.15 in) minimum and that care should be taken when designing spindles to avoid interference.

6 Means of attaching film to all cores are optional. Commonly used are cores having one anchoring slot or two anchoring slots angled in opposite directions. The latter facilitates film attachment whichever way the core is placed on its spindle. It is recommended that the edges of any slot, if used, be depressed slightly to minimize pressure marks in the first few convolutions of the film.

7 The rather large tolerances on dimension *B* are necessary to encompass the satisfactory existing practices of many different manufacturers. It is expected, however, that cores made by any one manufacturer would be held to a considerably smaller tolerance range. This will help prevent large variations, including undue tapering of the core from one side to the other, of any manufacturer's product.

2 SIMPLE CORES FOR 8, 16, 17,5, 32, 35, 65 and 70 mm FILMS

Dimensions in millimetres (inches)

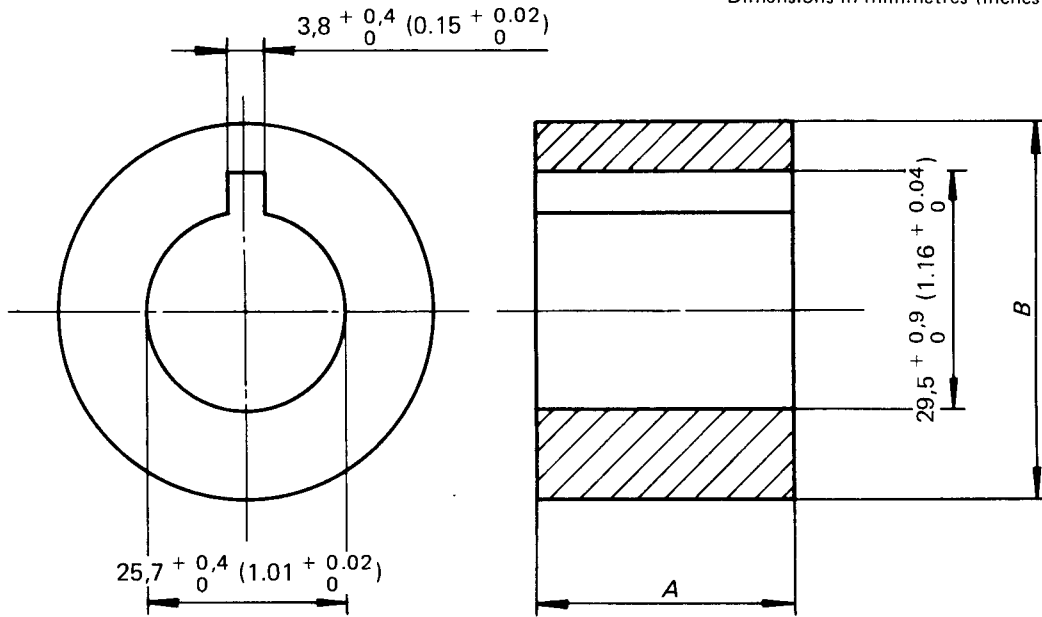

FIGURE 1 – Dimensions common to all simple cores

TABLE – Variable dimensions of simple cores

Nominal core size mm	Dimension	mm		in	
		mm	in	mm	in
8 × 50	A	7,9 ⁰ _{-0,5}	0,31 ⁰ _{-0,02}	50,0 ± 0,5	1,97 ± 0,02
	B	50,0 ± 0,5	1,97 ± 0,02	15,9 ⁰ _{-0,5}	0,62 ⁰ _{-0,02}
16 × 50	A	15,9 ⁰ _{-0,5}	0,62 ⁰ _{-0,02}	50,0 ± 0,5	1,97 ± 0,02
	B	50,0 ± 0,5	1,97 ± 0,02	75,0 ^{+2,0} _{-1,0}	2,95 ^{+0,08} _{-0,04}
16 × 75	A	15,9 ⁰ _{-0,5}	0,62 ⁰ _{-0,02}	100,0 ± 1,0	3,94 ± 0,04
	B	100,0 ± 1,0	3,94 ± 0,04	17,4 ⁰ _{-0,5}	0,68 ⁰ _{-0,02}
17,5 × 100	A	17,4 ⁰ _{-0,5}	0,68 ⁰ _{-0,02}	100,0 ± 1,0	3,94 ± 0,04
	B	100,0 ± 1,0	3,94 ± 0,04	31,8 ⁰ _{-1,0}	1,26 ⁰ _{-0,04}
32 × 50	A	31,8 ⁰ _{-1,0}	1,26 ⁰ _{-0,04}	50,0 ± 0,5	1,97 ± 0,02
	B	50,0 ± 0,5	1,97 ± 0,02	34,9 ⁰ _{-1,0}	1,37 ⁰ _{-0,04}
35 × 50	A	34,9 ⁰ _{-1,0}	1,37 ⁰ _{-0,04}	50,0 ± 0,5	1,97 ± 0,02
	B	50,0 ± 0,5	1,97 ± 0,02	34,9 ⁰ _{-1,0}	1,37 ⁰ _{-0,04}
35 × 75	A	34,9 ⁰ _{-1,0}	1,37 ⁰ _{-0,04}	75,0 ^{+2,0} _{-1,0}	2,95 ^{+0,08} _{-0,04}
	B	75,0 ^{+2,0} _{-1,0}	2,95 ^{+0,08} _{-0,04}	34,9 ⁰ _{-1,0}	1,37 ⁰ _{-0,04}
35 × 100	A	34,9 ⁰ _{-1,0}	1,37 ⁰ _{-0,04}	100,0 ± 1,0	3,94 ± 0,04
	B	100,0 ± 1,0	3,94 ± 0,04	64,9 ⁰ _{-1,0}	2,56 ⁰ _{-0,04}
65 × 75	A	64,9 ⁰ _{-1,0}	2,56 ⁰ _{-0,04}	75,0 ^{+2,0} _{-1,0}	2,95 ^{+0,08} _{-0,04}
	B	75,0 ^{+2,0} _{-1,0}	2,95 ^{+0,08} _{-0,04}	69,9 ⁰ _{-1,0}	2,75 ⁰ _{-0,04}
70 × 75	A	69,9 ⁰ _{-1,0}	2,75 ⁰ _{-0,04}	75,0 ^{+2,0} _{-1,0}	2,95 ^{+0,08} _{-0,04}
	B	75,0 ^{+2,0} _{-1,0}	2,95 ^{+0,08} _{-0,04}		

3 INTERMEDIATE CORE FOR "60 mm X 78 mm" CORES (FOR REDUCING SPINDLE HOLE SIZE)

Dimensions in millimetres (inches)

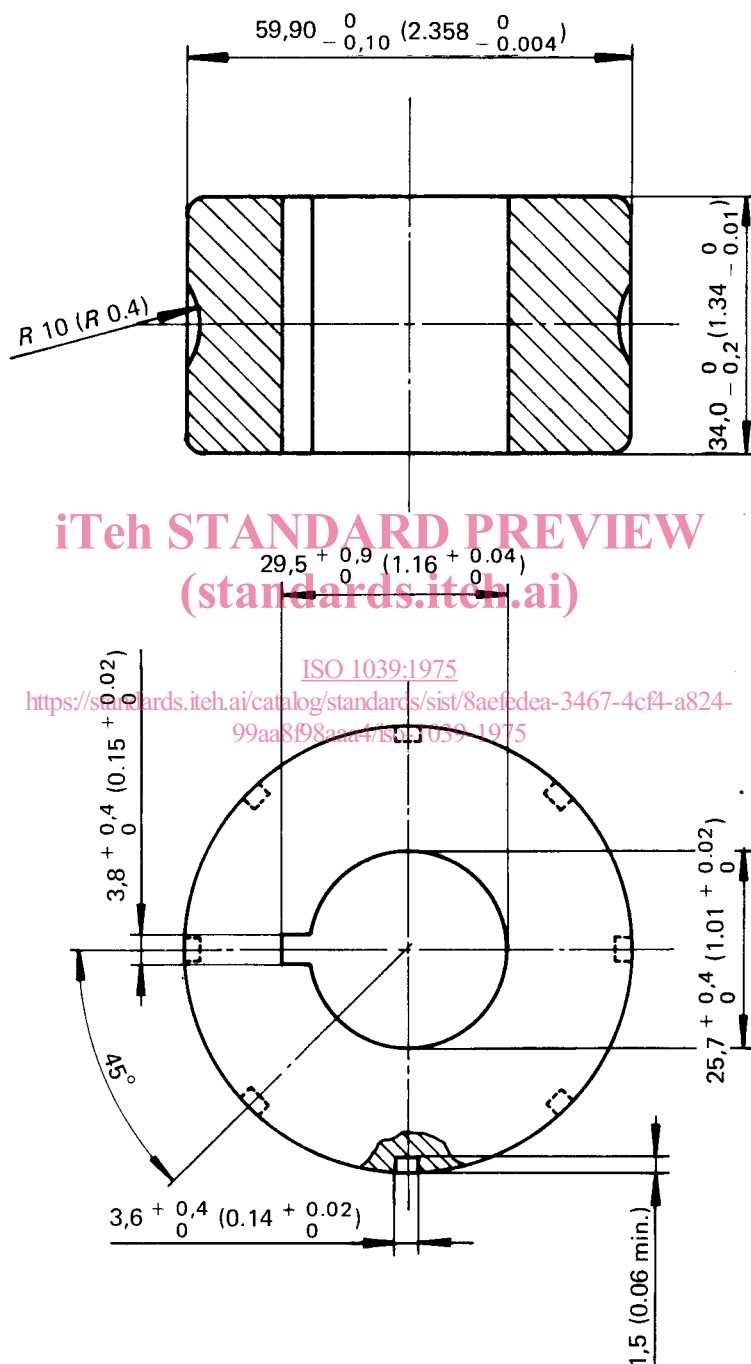

FIGURE 2 – Dimensions for intermediate cores

4 "60 mm X 78 mm" CORE WITH LIGHT LOCK GROOVES AND SPRING DETENTS FOR 35 mm FILM

Dimensions in millimetres (inches)

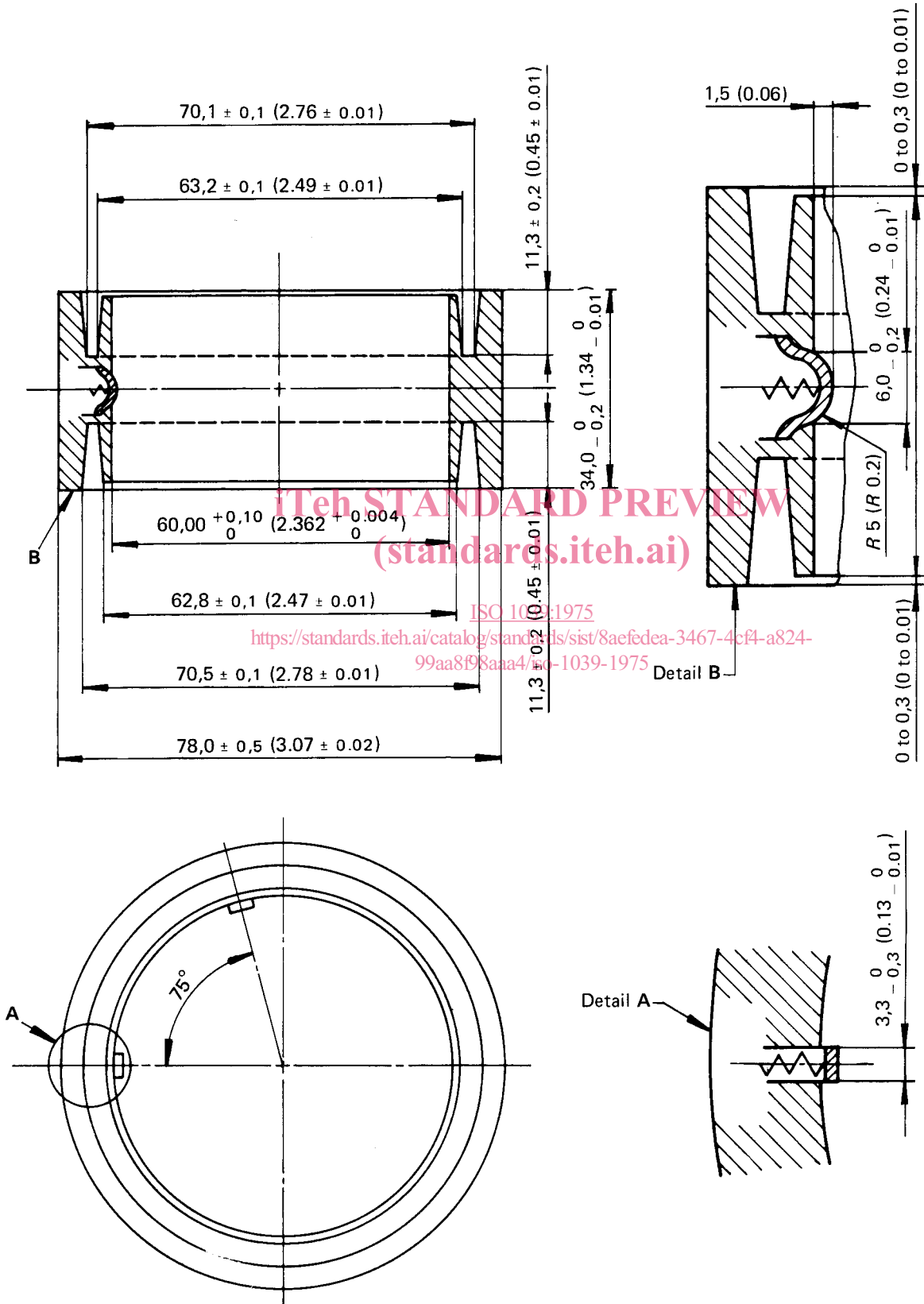

FIGURE 3 – Dimensions for core with light lock groove

iTeh STANDARD PREVIEW
(standards.iteh.ai)

[ISO 1039:1975](#)

<https://standards.iteh.ai/catalog/standards/sist/8aefedea-3467-4cf4-a824-99aa8f98aaa4/iso-1039-1975>

iTeh STANDARD PREVIEW
(standards.iteh.ai)

[ISO 1039:1975](#)

<https://standards.iteh.ai/catalog/standards/sist/8aefedea-3467-4cf4-a824-99aa8f98aaa4/iso-1039-1975>