INTERNATIONAL STANDARD



1041

INTERNATIONAL ORGANIZATION FOR STANDARDIZATION • МЕЖДУНАРОДНАЯ ОРГАНИЗАЦИЯ ПО СТАНДАРТИЗАЦИИ • ORGANISATION INTERNATIONALE DE NORMALISATION

Essential oils – Determination of freezing point

First edition – 1973-12-01

ITeH STANDARD PREVIEW
(standards.iteh.ai)

[ISO 1041:1973](https://standards.iteh.ai/catalog/standards/sist/80c264e0-0bee-45c5-afae-8fe4e5d703b0/iso-1041-1973)

<https://standards.iteh.ai/catalog/standards/sist/80c264e0-0bee-45c5-afae-8fe4e5d703b0/iso-1041-1973>



UDC 668.5 : 536.421.4

Ref. No. ISO 1041-1973 (E)

Descriptors : Essential oils, tests, physical tests, solidification points.

FOREWORD

ISO (the International Organization for Standardization) is a worldwide federation of national standards institutes (ISO Member Bodies). The work of developing International Standards is carried out through ISO Technical Committees. Every Member Body interested in a subject for which a Technical Committee has been set up has the right to be represented on that Committee. International organizations, governmental and non-governmental, in liaison with ISO, also take part in the work.

Draft International Standards adopted by the Technical Committees are circulated to the Member Bodies for approval before their acceptance as International Standards by the ISO Council.

Prior to 1972, the results of the work of the Technical Committees were published as ISO Recommendations; these documents are now in the process of being transformed into International Standards. As part of this process, Technical Committee ISO/TC 54 has reviewed ISO Recommendation R 1041 and found it suitable for transformation. International Standard ISO therefore replaces ISO Recommendation R 1041-1969.

<https://standards.iteh.ai/catalog/standards/sist/80c264e0-0bee-45c5-afae-8fa4e5d70310/iso-1041-1973>

ISO Recommendation R 1041 was approved by the Member Bodies of the following countries :

Argentina	Germany	Portugal
Australia	Greece	Romania
Austria	India	Spain
Belgium	Italy	Sweden
Canada	Morocco	United Kingdom
Chile	Netherlands	U.S.S.R.
France	New Zealand	Yugoslavia

No Member Body expressed disapproval of the Recommendation.

Essential oils – Determination of freezing point

1 SCOPE AND FIELD OF APPLICATION

This International Standard specifies a method of determining the freezing points of essential oils. It is not applicable in the special case of essential oil of rose.

2 REFERENCES

ISO 212, *Essential oils – Sampling*.

ISO/R 356, *Essential oils – Methods of test – Preparation of sample*.

3 DEFINITION

For the purpose of this International Standard, the following definition applies :

freezing point : Either the constant temperature, or the maximum temperature, observed when the oil, in a supercooled liquid state, liberates its latent heat of fusion.

4 PRINCIPLE

Slow and progressive cooling of the essential oil.

Observation of the variations in temperature as the oil passes from the liquid to the solid state.

5 APPARATUS

5.1 Calibrated thermometers, fulfilling the following requirements :

length of bulb : 10 to 20 mm

diameter of bulb : 5 to 6 mm

graduations : 0,1 °C

It is essential that the set of thermometers used (see ISO/R 653) should permit the measurement of any temperature between – 20 and + 50 °C.

The relevant International Standards for the essential oils indicate which thermometer shall be used.

5.2 Test tube, about 20 mm in diameter and 100 mm long.

5.3 Stout-walled test tube, about 30 mm in diameter and 125 mm long.

5.4 Apparatus assembly for determination of freezing point, consisting of a wide-mouthed container of about 500 ml capacity, provided with a bored cork or rubber stopper into which the stout-walled test tube (5.3) is inserted. The test tube (5.2) is fitted into the stout-walled test tube (5.3) by means of another bored cork or rubber stopper. Into the test tube (5.2) a thermometer (5.1) is inserted, so that the centre of its mercury bulb is located at the centre of the liquid.

A suitable apparatus assembly is shown in the figure.

6 SAMPLING

See ISO 212.

7 PROCEDURE

7.1 Preparation of test sample

See ISO/R 356.

7.2 Preliminary test

If necessary, first liquefy the essential oil by warming. Cool a few millilitres of the oil to be tested in a small test tube, and stir with a thermometer until solidification takes place.

Note the temperature and set aside in a cool place.

7.3 Determination

Fill the container (see 5.4) with water, melting ice or any suitable freezing mixture, so as to obtain a temperature 5 °C lower than that noted in the preliminary test. Fit the stout-walled test tube (5.3) in its place.

Into the test tube (5.2), place 10 ml of the essential oil, liquefied if necessary, insert the thermometer and carefully cool the oil to the temperature indicated in the preliminary test. Now insert the test tube (5.2) in the stout-walled tube (5.3) of the apparatus and allow the temperature to fall a further 2 °C.

Seed the oil with a trace of the solidified oil, obtained in the preliminary test, and stir vigorously with the thermometer, taking care to avoid the adhesion of particles to the walls of the tube. Observe the temperature variations as carefully as possible.

Note the observed temperature when the temperature curve in relation to time shows a maximum value, or a constant level for at least 1 min.

Remove the test tube (5.2) from the apparatus and again liquefy the essential oil. Repeat the determination until two consecutive results do not differ by more than 0,2 °C. Average the two last readings to obtain the final figure.

8 EXPRESSION OF RESULTS

The freezing point is the maximum temperature observed at the end of the test. It is expressed in degrees Celsius to one decimal place.

9 TEST REPORT

The test report shall include the following particulars :

- a) the reference of the method used;
- b) the results and the method of expression used;
- c) any unusual features noted during the determination;
- d) any operation not included in this International Standard, or regarded as optional.

Dimensions in millimetres

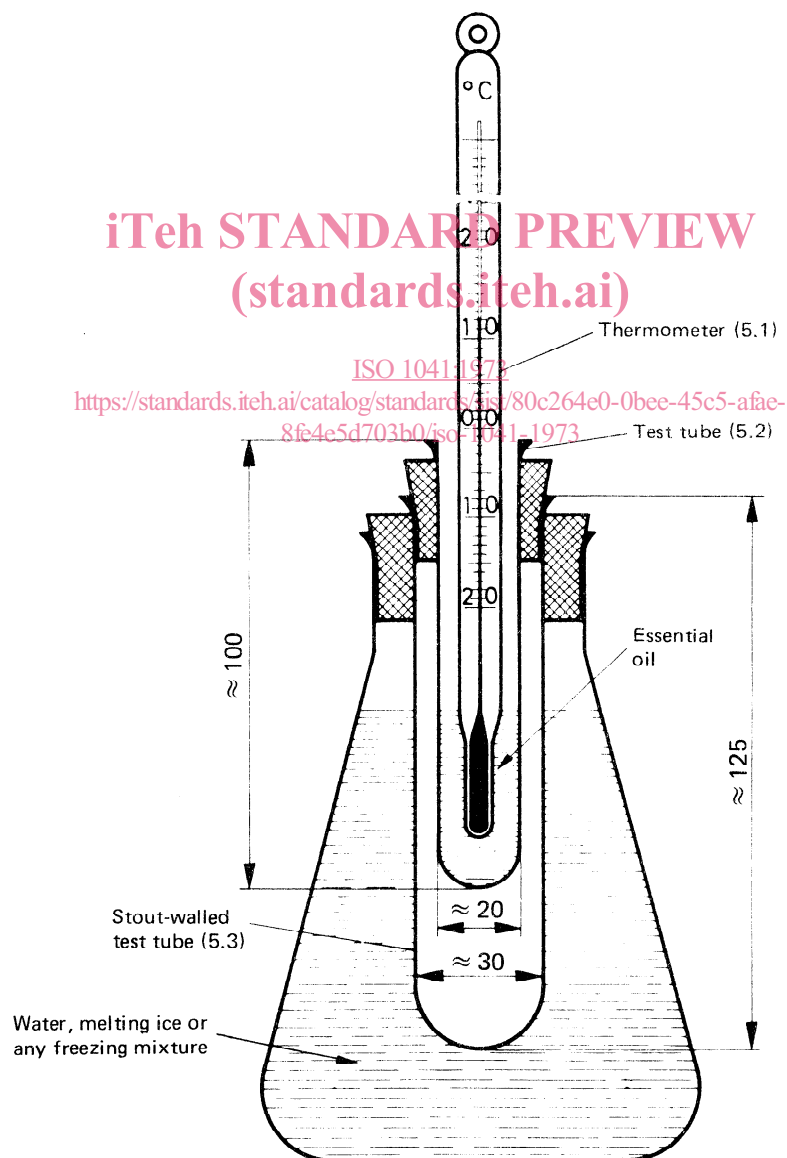

FIGURE — Suitable apparatus assembly for determination of freezing point