

ETSI TS 138 401 V15.2.0 (2018-07)



TECHNICAL SPECIFICATION

**5G;
NG-RAN;
Architecture description
(3GPP TS 38.401 version 15.2.0 Release 15)**

*Full document available at
https://standards.iteh.ai/catalog/standards/sist/ec793328-0f0c-419b-bc66-dbb355c1eeb4/etsi-ts-138-401-v15-2-0-2018-07*



Reference

DTS/TSGR-0338401vf20

Keywords

5G

ETSI

650 Route des Lucioles
F-06921 Sophia Antipolis Cedex - FRANCE

Tel.: +33 4 92 94 42 00 Fax: +33 4 93 65 47 16

Siret N° 348 623 562 00017 - NAF 742 C
Association à but non lucratif enregistrée à la
Sous-Préfecture de Grasse (06) N° 7803/88

Important notice

The present document can be downloaded from:
<http://www.etsi.org/standards-search>

The present document may be made available in electronic versions and/or in print. The content of any electronic and/or print versions of the present document shall not be modified without the prior written authorization of ETSI. In case of any existing or perceived difference in contents between such versions and/or in print, the only prevailing document is the print of the Portable Document Format (PDF) version kept on a specific network drive within ETSI Secretariat.

Users of the present document should be aware that the document may be subject to revision or change of status. Information on the current status of this and other ETSI documents is available at
<https://portal.etsi.org/TB/ETSIDeliverableStatus.aspx>

If you find errors in the present document, please send your comment to one of the following services:
<https://portal.etsi.org/People/CommiteeSupportStaff.aspx>

Copyright Notification

No part may be reproduced or utilized in any form or by any means, electronic or mechanical, including photocopying and microfilm except as authorized by written permission of ETSI.

The content of the PDF version shall not be modified without the written authorization of ETSI.

The copyright and the foregoing restriction extend to reproduction in all media.

© ETSI 2018.
All rights reserved.

DECT™, **PLUGTESTS™**, **UMTS™** and the ETSI logo are trademarks of ETSI registered for the benefit of its Members.
3GPP™ and **LTE™** are trademarks of ETSI registered for the benefit of its Members and of the 3GPP Organizational Partners.

oneM2M logo is protected for the benefit of its Members.

GSM® and the GSM logo are trademarks registered and owned by the GSM Association.

Intellectual Property Rights

Essential patents

IPRs essential or potentially essential to normative deliverables may have been declared to ETSI. The information pertaining to these essential IPRs, if any, is publicly available for **ETSI members and non-members**, and can be found in ETSI SR 000 314: *"Intellectual Property Rights (IPRs); Essential, or potentially Essential, IPRs notified to ETSI in respect of ETSI standards"*, which is available from the ETSI Secretariat. Latest updates are available on the ETSI Web server (<https://ipr.etsi.org/>).

Pursuant to the ETSI IPR Policy, no investigation, including IPR searches, has been carried out by ETSI. No guarantee can be given as to the existence of other IPRs not referenced in ETSI SR 000 314 (or the updates on the ETSI Web server) which are, or may be, or may become, essential to the present document.

Trademarks

The present document may include trademarks and/or tradenames which are asserted and/or registered by their owners. ETSI claims no ownership of these except for any which are indicated as being the property of ETSI, and conveys no right to use or reproduce any trademark and/or tradename. Mention of those trademarks in the present document does not constitute an endorsement by ETSI of products, services or organizations associated with those trademarks.

Foreword

This Technical Specification (TS) has been produced by ETSI 3rd Generation Partnership Project (3GPP).

The present document may refer to technical specifications or reports using their 3GPP identities, UMTS identities or GSM identities. These should be interpreted as being references to the corresponding ETSI deliverables.

The cross reference between GSM, UMTS, 3GPP and ETSI identities can be found under <http://webapp.etsi.org/key/queryform.asp>.

Modal verbs terminology

In the present document **"shall"**, **"shall not"**, **"should"**, **"should not"**, **"may"**, **"need not"**, **"will"**, **"will not"**, **"can"** and **"cannot"** are to be interpreted as described in clause 3.2 of the [ETSI Drafting Rules](#) (Verbal forms for the expression of provisions).

"must" and **"must not"** are **NOT** allowed in ETSI deliverables except when used in direct citation.

Contents

Intellectual Property Rights	2
Foreword.....	2
Modal verbs terminology.....	2
Foreword.....	5
1 Scope	6
2 References	6
3 Definitions and abbreviations.....	6
3.1 Definitions	6
3.2 Abbreviations	7
4 General principles	8
5 General architecture	8
5.1 General	8
5.2 User plane.....	8
5.3 Control plane.....	9
6 NG-RAN architecture.....	10
6.1 Overview	10
6.1.1 Overall Architecture of NG-RAN.....	10
6.1.2 Overall architecture for separation of gNB-CU-CP and gNB-CU-UP	11
6.2 NG-RAN identifiers	11
6.2.1 Principle of handling Application Protocol Identities.....	11
6.2.2 gNB-DU ID	13
6.3 Transport addresses	13
6.4 UE associations in NG-RAN Node.....	13
7 NG-RAN functions description.....	14
7.0 General	14
7.1 Void.....	14
8 Overall procedures in gNB-CU/gNB-DU Architecture	14
8.1 UE Initial Access.....	14
8.2 Intra-gNB-CU Mobility.....	16
8.2.1 Intra-NR Mobility	16
8.2.1.1 Inter-gNB-DU Mobility	16
8.2.1.2 Intra-gNB-DU handover	17
8.2.2 EN-DC Mobility	17
8.2.2.1 Inter-gNB-DU Mobility using MCG SRB	17
8.2.2.2 Inter-gNB-DU Mobility using SCG SRB	19
8.3 Mechanism of centralized retransmission of lost PDUs.....	19
8.3.1 Centralized Retransmission in Intra gNB-CU Cases	19
8.4 Multi-Connectivity operation	20
8.4.1 Secondary Node Addition.....	20
8.4.1.1 EN-DC	20
8.4.2 Secondary Node Release (MN/SN initiated)	21
8.4.2.1 EN-DC	21
8.5 F1 Startup and cells activation	22
8.6 RRC state transition.....	23
8.6.1 RRC connected to RRC inactive.....	23
8.6.2 RRC inactive to other states.....	23
8.7 RRC connection reestablishment	25
8.8 Multiple TNLAs for F1-C	26
8.9 Overall procedures involving E1 and F1	27
8.9.1 UE Initial Access	27
8.9.2 Bearer context setup over F1-U	28
8.9.3 Bearer context release over F1-U	29

8.9.3.1	gNB-CU-CP initiated bearer context release	29
8.9.3.2	gNB-CU-UP initiated bearer context release	29
8.9.4	Inter-gNB handover involving gNB-CU-UP change	30
8.9.5	Change of gNB-CU-UP	31
8.9.6	RRC State transition	32
8.9.6.1	RRC Connected to RRC Inactive	32
8.9.6.2	RRC Inactive to other states	33
9	Synchronization	35
9.1	gNB Synchronization	35
10	NG-RAN interfaces	35
10.1	NG interface	35
10.2	Xn interface	35
10.3	F1 interface	35
10.4	E1 interface	36
Annex A (informative):	Deployment scenarios of gNB/en-gNB	37
Annex B (informative):	Change History	38
History		39

iTeh STANDARD PREVIEW
(standards.iteh.ai)

Full standard:
<https://standards.iteh.ai/catalog/standards/sist/ec793328-0f0c-419b-bc66-dbb355c1eeb4/etsi-ts-138-401-v15.2.0-2018-07>

Foreword

This Technical Specification has been produced by the 3rd Generation Partnership Project (3GPP).

The contents of the present document are subject to continuing work within the TSG and may change following formal TSG approval. Should the TSG modify the contents of the present document, it will be re-released by the TSG with an identifying change of release date and an increase in version number as follows:

Version x.y.z

where:

- x the first digit:
 - 1 presented to TSG for information;
 - 2 presented to TSG for approval;
 - 3 or greater indicates TSG approved document under change control.
- y the second digit is incremented for all changes of substance, i.e. technical enhancements, corrections, updates, etc.
- z the third digit is incremented when editorial only changes have been incorporated in the document.

ITeH STANDARD PREVIEW
(standards.iteh.ai)
Full standard:
<https://standards.iteh.ai/catalog/standards/sist/ec793328-0f0c-419b-bc66-dbb355c1eeb4/etsi-ts-138-401-v15.2.0-2018-07>

1 Scope

The present document describes the overall architecture of the NG-RAN, including interfaces NG, Xn and F1 interfaces and their interaction with the radio interface.

2 References

The following documents contain provisions which, through reference in this text, constitute provisions of the present document.

- References are either specific (identified by date of publication, edition number, version number, etc.) or non-specific.
- For a specific reference, subsequent revisions do not apply.
- For a non-specific reference, the latest version applies. In the case of a reference to a 3GPP document (including a GSM document), a non-specific reference implicitly refers to the latest version of that document *in the same Release as the present document*.

- [1] 3GPP TR 21.905: "Vocabulary for 3GPP Specifications".
- [2] 3GPP TS 38.300: "NR; Overall description; Stage-2".
- [3] 3GPP TS 23.501: "System Architecture for the 5G System".
- [4] 3GPP TS 38.473: "NG-RAN; F1 application protocol (F1AP)".
- [5] 3GPP TS 38.414: "NG-RAN; NG data transport".
- [6] 3GPP TS 38.424: "NG-RAN; Xn data transport".
- [7] 3GPP TS 38.474: "NG-RAN; F1 data transport".
- [8] ITU-T Recommendation G.823 (2000-03): "The control of jitter and wander within digital networks which are based on the 2048 kbit/s hierarchy".
- [9] ITU-T Recommendation G.824 (2000-03): "The control of jitter and wander within digital networks which are based on the 1544 kbit/s hierarchy".
- [10] ITU-T Recommendation G.825 (2001-08): "The control of jitter and wander within digital networks which are based on the synchronous digital hierarchy (SDH)".
- [11] ITU-T Recommendation G.8261/Y.1361 (2008-04): "Timing and Synchronization aspects in Packet networks".
- [12] 3GPP TS 37.340: "NR; Multi-connectivity; Overall description; Stage-2".
- [13] 3GPP TS 33.501: "Security Architecture and Procedures for 5G System".
- [14] 3GPP TS 38.410: "NG-RAN; NG general aspect and principles".
- [15] 3GPP TS 38.420: "NG-RAN; Xn general aspects and principles".
- [16] 3GPP TS 38.470: "NG-RAN; F1 general aspects and principles".
- [17] 3GPP TS 38.460: "NG-RAN; E1 general aspects and principles".

3 Definitions and abbreviations

3.1 Definitions

For the purposes of the present document, the terms and definitions given in TR 21.905 [1] and the following apply. A term defined in the present document takes precedence over the definition of the same term, if any, in TR 21.905 [1].

en-gNB: as defined in TS 37.340 [12].

gNB: as defined in TS 38.300 [2].

gNB Central Unit (gNB-CU): a logical node hosting RRC, SDAP and PDCP protocols of the gNB or RRC and PDCP protocols of the en-gNB that controls the operation of one or more gNB-DUs. The gNB-CU terminates the F1 interface connected with the gNB-DU.

gNB Distributed Unit (gNB-DU): a logical node hosting RLC, MAC and PHY layers of the gNB or en-gNB, and its operation is partly controlled by gNB-CU. One gNB-DU supports one or multiple cells. One cell is supported by only one gNB-DU. The gNB-DU terminates the F1 interface connected with the gNB-CU.

gNB-CU-Control Plane (gNB-CU-CP): a logical node hosting the RRC and the control plane part of the PDCP protocol of the gNB-CU for an en-gNB or a gNB. The gNB-CU-CP terminates the E1 interface connected with the gNB-CU-UP and the F1-C interface connected with the gNB-DU.

gNB-CU-User Plane (gNB-CU-UP): a logical node hosting the user plane part of the PDCP protocol of the gNB-CU for an en-gNB, and the user plane part of the PDCP protocol and the SDAP protocol of the gNB-CU for a gNB. The gNB-CU-UP terminates the E1 interface connected with the gNB-CU-CP and the F1-U interface connected with the gNB-DU.

NG-RAN node: as defined in TS 38.300 [2].

PDU Session Resource: This term is used for specification of NG, Xn, and E1 interfaces. It denotes NG-RAN interface and radio resources provided to support a PDU Session.

3.2 Abbreviations

For the purposes of the present document, the terms and definitions given in TR 21.905 [1] and the following apply. A term defined in the present document takes precedence over the definition of the same term, if any, in TR 21.905 [1].

5GC	5G Core Network
AMF	Access and Mobility Management Function
AP	Application Protocol
AS	Access Stratum
CM	Connection Management
CMAS	Commercial Mobile Alert Service
ETWS	Earthquake and Tsunami Warning System
F1-U	F1 User plane interface
F1-C	F1 Control plane interface
F1AP	F1 Application Protocol
FDD	Frequency Division Duplex
GTP-U	GPRS Tunnelling Protocol
IP	Internet Protocol
NAS	Non-Access Stratum
O&M	Operation and Maintenance
PWS	Public Warning System
QoS	Quality of Service
RNL	Radio Network Layer
RRC	Radio Resource Control
SAP	Service Access Point
SCTP	Stream Control Transmission Protocol
SFN	System Frame Number
SM	Session Management
SMF	Session Management Function
TDD	Time Division Duplex
TDM	Time Division Multiplexing
TNL	Transport Network Layer

4 General principles

The general principles guiding the definition of NG-RAN architecture as well as the NG-RAN interfaces are the following:

- Logical separation of signalling and data transport networks.
- NG-RAN and 5GC functions are fully separated from transport functions. Addressing scheme used in NG-RAN and 5GC shall not be tied to the addressing schemes of transport functions. The fact that some NG-RAN or 5GC functions reside in the same equipment as some transport functions does not make the transport functions part of the NG-RAN or the 5GC.
- Mobility for an RRC connection is fully controlled by the NG-RAN.
- The NG-RAN interfaces are defined along the following principles:
 - The functional division across the interfaces have as few options as possible.
 - Interfaces are based on a logical model of the entity controlled through this interface.
 - One physical network element can implement multiple logical nodes.

5 General architecture

5.1 General

The protocols over Uu and NG interfaces are divided into two structures:

- **User plane protocols**

These are the protocols implementing the actual PDU Session service, i.e. carrying user data through the access stratum.

- **Control plane protocols**

These are the protocols for controlling the PDU Sessions and the connection between the UE and the network from different aspects (including requesting the service, controlling different transmission resources, handover etc.). Also a mechanism for transparent transfer of NAS messages is included.

5.2 User plane

The PDU Session Resource service is offered from SAP to SAP by the Access Stratum. Figure 5.2-1 shows the protocols on the Uu and the NG interfaces that linked together provide this PDU Session Resource service.

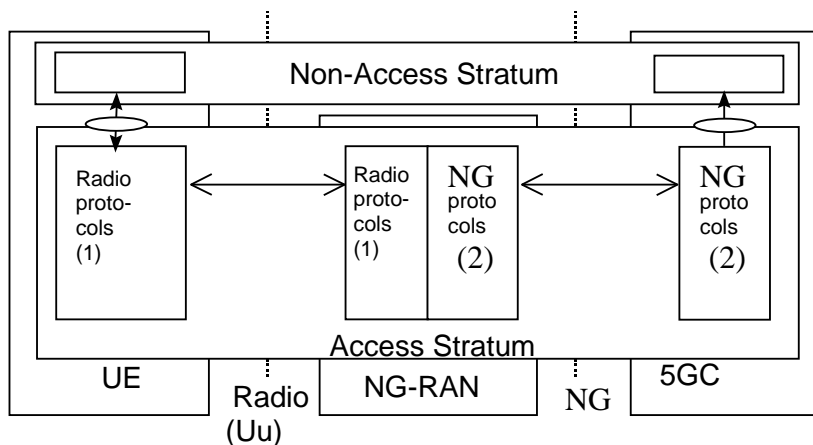

NOTE 1: The radio interface protocols are defined in 3GPP TS 38.2xx and TS 38.3xx.
 NOTE 2: The NG interface protocols are defined in 3GPP TS 38.41x.

Figure 5.2-1: NG and Uu user plane

5.3 Control plane

Figure 5.3-1 shows the control plane (signalling) protocol stacks on NG and Uu interfaces.

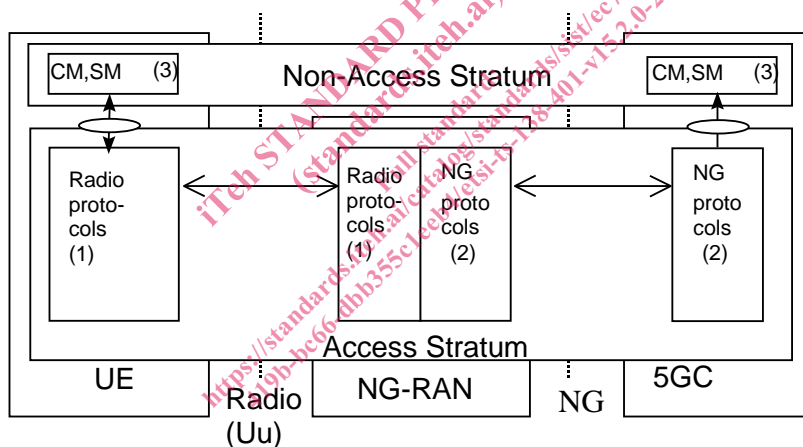

NOTE 1: The radio interface protocols are defined in 3GPP TS 38.2xx and TS 38.3xx.
 NOTE 2: The protocol is defined in 3GPP TS 38.41x. (Description of NG interface).
 NOTE 3: CM, SM: This exemplifies a set of NAS control protocols between UE and 5GC. The evolution of the protocol architecture for these protocols is outside the scope of the present document.

Figure 5.3-1: NG and Uu control plane

NOTE: Both the Radio protocols and the NG protocols contain a mechanism to transparently transfer NAS messages.

6 NG-RAN architecture

6.1 Overview

6.1.1 Overall Architecture of NG-RAN

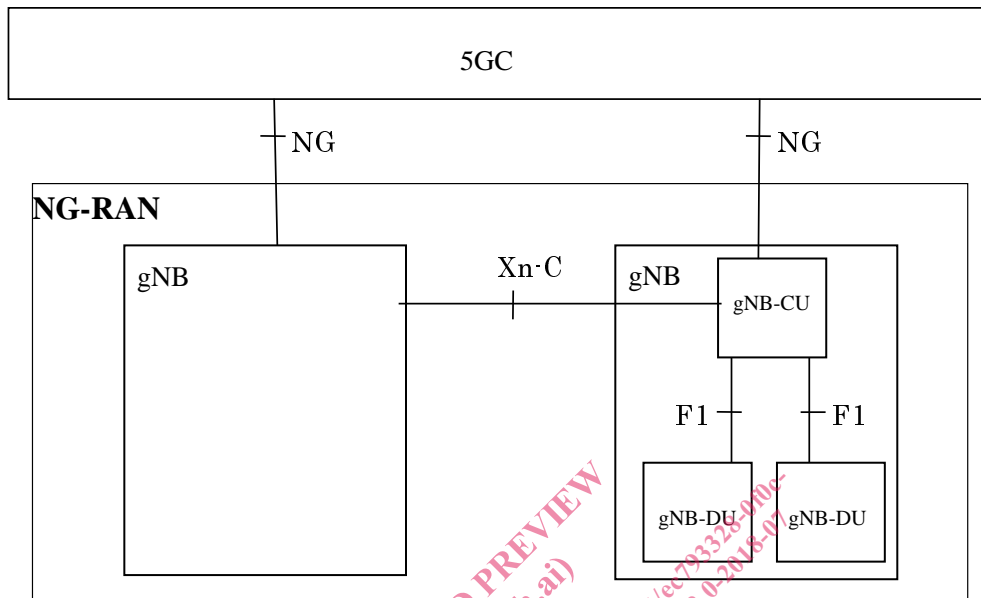

Figure 6.1-1: Overall architecture

The NG-RAN consists of a set of gNBs connected to the 5GC through the NG interface.

An gNB can support FDD mode, TDD mode or dual mode operation.

gNBs can be interconnected through the Xn interface

A gNB may consist of a gNB-CU and one or more gNB-DU(s). A gNB-CU and a gNB-DU is connected via F1 interface.

One gNB-DU is connected to only one gNB-CU.

NOTE: For resiliency, a gNB-DU may be connected to multiple gNB-CUs by appropriate implementation.

NG, Xn and F1 are logical interfaces.

For NG-RAN, the NG and Xn-C interfaces for a gNB consisting of a gNB-CU and gNB-DUs, terminate in the gNB-CU. For EN-DC, the S1-U and X2-C interfaces for a gNB consisting of a gNB-CU and gNB-DUs, terminate in the gNB-CU. The gNB-CU and connected gNB-DUs are only visible to other gNBs and the 5GC as a gNB. A possible deployment scenario is described in Annex A.

The node hosting user plane part of NR PDCP (e.g. gNB-CU, gNB-CU-UP, and for EN-DC, MeNB or SgNB depending on the bearer split) shall perform user inactivity monitoring and further informs its inactivity or (re)activation to the node having C-plane connection towards the core network (e.g. over E1, X2). The node hosting NR RLC (e.g. gNB-DU) may perform user inactivity monitoring and further inform its inactivity or (re)activation to the node hosting control plane, e.g. gNB-CU or gNB-CU-CP.

UL PDCP configuration (i.e. how the UE uses the UL at the assisting node) is indicated via X2-C (for EN-DC), Xn-C (for NG-RAN) and F1-C. Radio Link Outage/Resume for DL and/or UL is indicated via X2-U (for EN-DC), Xn-U (for NG-RAN) and F1-U.

The NG-RAN is layered into a Radio Network Layer (RNL) and a Transport Network Layer (TNL).

The NG-RAN architecture, i.e. the NG-RAN logical nodes and interfaces between them, is defined as part of the RNL.

For each NG-RAN interface (NG, Xn, F1) the related TNL protocol and the functionality are specified. The TNL provides services for user plane transport, signalling transport.

In NG-Flex configuration, each gNB is connected to all AMFs within an AMF Region. The AMF Region is defined in 3GPP TS 23.501 [3].

If security protection for control plane and user plane data on TNL of NG-RAN interfaces has to be supported, NDS/IP 3GPP TS 33.501 [13] shall be applied.

6.1.2 Overall architecture for separation of gNB-CU-CP and gNB-CU-UP

The overall architecture for separation of gNB-CU-CP and gNB-CU-UP is depicted in Figure 6.1.2-1.

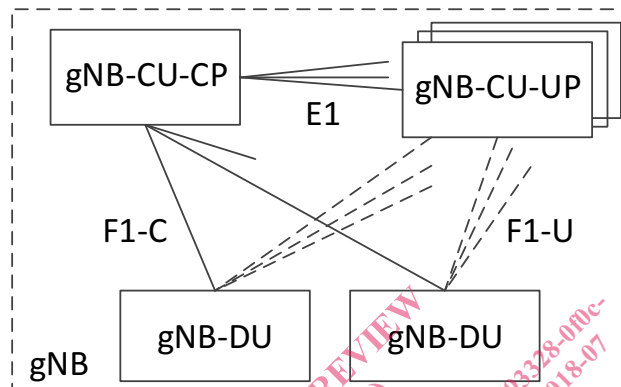

Figure 6.1.2-1. Overall architecture for separation of gNB-CU-CP and gNB-CU-UP

- A gNB may consist of a gNB-CU-CP, multiple gNB-CU-UPs and multiple gNB-DUs;
- A gNB may consist of a gNB-CU-CP, multiple gNB-CU-UPs and multiple gNB-DUs;
- The gNB-CU-CP is connected to the gNB-DU through the F1-C interface;
- The gNB-CU-UP is connected to the gNB-DU through the F1-U interface;
- The gNB-CU-UP is connected to the gNB-CU-CP through the E1 interface;
- One gNB-DU is connected to only one gNB-CU-CP;
- One gNB-CU-UP is connected to only one gNB-CU-CP;

NOTE 1: For resiliency, a gNB-DU and/or a gNB-CU-UP may be connected to multiple gNB-CU-CPs by appropriate implementation.

- One gNB-DU can be connected to multiple gNB-CU-UPs under the control of the same gNB-CU-CP;
- One gNB-CU-UP can be connected to multiple DUs under the control of the same gNB-CU-CP;

NOTE 2: The connectivity between a gNB-CU-UP and a gNB-DU is established by the gNB-CU-CP using Bearer Context Management functions.

NOTE 3: The gNB-CU-CP selects the appropriate gNB-CU-UP(s) for the requested services for the UE.

NOTE 4: Data forwarding between gNB-CU-UPs during intra-gNB-CU-CP handover within a gNB may be supported by Xn-U.

6.2 NG-RAN identifiers

6.2.1 Principle of handling Application Protocol Identities

An Application Protocol Identity (AP ID) is allocated when a new UE-associated logical connection is created in either an NG-RAN node or an AMF. An AP ID shall uniquely identify a logical connection associated to a UE over the NG