**Road vehicles — H-point machine
(HPM-II) — Specifications and procedure
for H-point determination**

*Véhicules routiers — Machine point H (HPM-II) — Spécifications et
procédure pour la détermination du point H*

iTeh STANDARD PREVIEW
(standards.iteh.ai)

[ISO 20176:2011](https://standards.iteh.ai/catalog/standards/sist/5c7884e5-a11a-474b-899c-1e8d9cff27ed/iso-20176-2011)

[https://standards.iteh.ai/catalog/standards/sist/5c7884e5-a11a-474b-899c-
1e8d9cff27ed/iso-20176-2011](https://standards.iteh.ai/catalog/standards/sist/5c7884e5-a11a-474b-899c-1e8d9cff27ed/iso-20176-2011)



PDF disclaimer

This PDF file may contain embedded typefaces. In accordance with Adobe's licensing policy, this file may be printed or viewed but shall not be edited unless the typefaces which are embedded are licensed to and installed on the computer performing the editing. In downloading this file, parties accept therein the responsibility of not infringing Adobe's licensing policy. The ISO Central Secretariat accepts no liability in this area.

Adobe is a trademark of Adobe Systems Incorporated.

Details of the software products used to create this PDF file can be found in the General Info relative to the file; the PDF-creation parameters were optimized for printing. Every care has been taken to ensure that the file is suitable for use by ISO member bodies. In the unlikely event that a problem relating to it is found, please inform the Central Secretariat at the address given below.

iTeh STANDARD PREVIEW
(standards.iteh.ai)

ISO 20176:2011

<https://standards.iteh.ai/catalog/standards/sist/5c7884e5-a11a-474b-899c-1e8d9cff27ed/iso-20176-2011>



COPYRIGHT PROTECTED DOCUMENT

© ISO 2011

All rights reserved. Unless otherwise specified, no part of this publication may be reproduced or utilized in any form or by any means, electronic or mechanical, including photocopying and microfilm, without permission in writing from either ISO at the address below or ISO's member body in the country of the requester.

ISO copyright office
Case postale 56 • CH-1211 Geneva 20
Tel. + 41 22 749 01 11
Fax + 41 22 749 09 47
E-mail copyright@iso.org
Web www.iso.org

Published in Switzerland

Contents

Page

Foreword	iv
Introduction.....	v
1 Scope	1
2 Normative references	1
3 Terms and definitions	1
4 Measurement procedure for the three-dimensional H-point machine	3
4.1 General	3
4.2 Summary of installation procedure	4
4.3 Prepare vehicle and seat	4
4.4 Determine the H-point travel path (optional)	5
4.5 Adjust seat to design intent	6
4.6 Install HPM cushion and back pan assembly	7
4.7 Load the HPM.....	9
4.8 Soak time.....	10
4.9 Record measurements — digitize HPM points.....	11
5 Optional measurements for driver seat	12
5.1 Leg and shoe installations	12
5.2 Record measurements.....	14
6 Optional measurements for the 2nd or succeeding row passenger seats	17
6.1 Leg and shoe installation	17
6.2 Record measurements for rear passengers	21
7 Additional optional measurements	23
7.1 Effective headroom	23
8 Remove the HPM	24
Annex A (normative) Description of the three-dimensional H-point machine (HPM)	25
Annex B (informative) HPM specification and tolerances	36
Annex C (informative) HPM field checking procedures	44
Annex D (informative) H-point design (HPD) tool description	60
Bibliography.....	63

Foreword

ISO (the International Organization for Standardization) is a worldwide federation of national standards bodies (ISO member bodies). The work of preparing International Standards is normally carried out through ISO technical committees. Each member body interested in a subject for which a technical committee has been established has the right to be represented on that committee. International organizations, governmental and non-governmental, in liaison with ISO, also take part in the work. ISO collaborates closely with the International Electrotechnical Commission (IEC) on all matters of electrotechnical standardization.

International Standards are drafted in accordance with the rules given in the ISO/IEC Directives, Part 2.

The main task of technical committees is to prepare International Standards. Draft International Standards adopted by the technical committees are circulated to the member bodies for voting. Publication as an International Standard requires approval by at least 75 % of the member bodies casting a vote.

Attention is drawn to the possibility that some of the elements of this document may be the subject of patent rights. ISO shall not be held responsible for identifying any or all such patent rights.

ISO 20176 was prepared by Technical Committee ISO/TC 22, *Road vehicles*, Subcommittee SC 13, *Ergonomics applicable to road vehicles*.

This second edition of ISO 20176 cancels and replaces the first edition (ISO 20176:2006), which has been technically revised. It also constitutes a technical revision of ISO 6549:1999.

It is the intent of ISO/TC 22/SC 13 that both ISO 20176 and ISO 6549:1999 be applicable until 2021-05-31. ISO 6549:1999 is thus provisionally retained until this date.

As from 2021-06-01, ISO 20176 will cancel and replace ISO 6549:1999.

During the transition period, it is the responsibility of vehicle designers to specify to regulatory and other bodies which document is applicable.

Introduction

The tools and procedures for H-point determination given in this International Standard are based on SAE J4002.

H-point devices are used during vehicle design and development to establish interior reference points and dimensions for occupant packaging, and to validate the location of these key reference points and dimensions on physical properties during audits.

H-point devices are also used for the design and validation of seats. However, in these instances, the reference points and dimensions are defined relative to the seat structure or surface, rather than the vehicle's interior. The procedures for positioning the H-point devices in seats do not require the use of the shoe tool or leg segments.

For convenience and simplicity, many terms associated with H-point devices use human body parts in their name. However, they should not be construed as measures that indicate occupant accommodation, human capabilities, or comfort. H-point devices do not represent the size or posture of any category of occupant.

a) Key differences from ISO 6549

Compared to the H-point machine (HPM) specified in ISO 6549, the HPM specified in this International Standard provides improved repeatability, greater ease of use, as well as additional features and measurement capabilities. All efforts were made to achieve these improvements while minimizing their impact on the location of reference points and measurements. Several of the changes are discussed below.

1) Separate components

ISO 20176:2011

[https://standards.iteh.ai/catalog/standards/sist/5c7884e5-a11a-474b-899c-](https://standards.iteh.ai/catalog/standards/sist/5c7884e5-a11a-474b-899c-1e8d9c77ed/iso-20176-2011)

For this HPM, the legs (upper and lower), shoe, cushion pan and back pan are all separate pieces. This greatly improves the ease of installation.

2) “Legless” manikin

The H-point location is defined without having to attach the legs. This is a major advantage. The procedure specified in this International Standard is based on installing the HPM without legs. Use of legs is optional.

3) Shoe tool

Several improvements were made to the shoe tool and how it is positioned in the vehicle, including:

- i) replacing the pedal reference point (PRP) with a new ball of foot reference point (BOFRP);
- ii) specifying a new procedure for positioning the shoe on the pedal.

4) Cushion angle

The cushion angle is now measured independently of thigh angle, and at the same time the other measurements are made. With the ISO 6549 HPM, cushion angle was measured from the thigh line, and required a separate installation of the HPM.

5) Lumbar support

The articulation of the back pan assembly allows the HPM specified in this International Standard to be better seated in contoured seats. It also provides a measurement of lumbar support prominence (LSP). This measurement provides an indication of the amount the seat back is contoured to provide support for the

ISO 20176:2011(E)

lumbar spine. The contour of the back pan assembly is most similar to the ISO 6549 H-point machine when the HPM is in a neutral posture (LSP equals zero).

b) Changes from ISO 20176:2006

The procedures for auditing the seat are essentially unchanged from the first edition. The most significant change is that the ball of foot (BOF) of the shoe does not have to be on the pedal surface. The HPM shoe can contact the pedal at any point(s) on the bottom of the shoe. The term pedal reference point (PRP) has been deleted (since the BOF may not be on the pedal) and replaced by a new term called the ball of foot reference point (BOFRP). The accelerator heel point (AHP) to BOF distance was changed from 200 mm to 203 mm to be consistent with ISO 6549, SAE J1100, and vehicle manufacturers around the world.

The following physical modifications were made to the HPM. The flat part of the shoe bottom was extended from 200 mm to 203 mm. A new scale was added to the top of the shoe to aid in determining the pedal contact point (PCP). A new H-point divot was added to allow coordinate measuring machine (CMM) point taking from above. The knee angle scale was recessed to improve its durability and reoriented to improve its readability. Several figures were revised to illustrate these changes.

The terms pedal plane and pedal plane angle (PPA) have been replaced by shoe plane and shoe plane angle (SPA). These new terms more accurately convey the meaning. SPA is a side view angle that is provided by the vehicle manufacturer.

iTeh STANDARD PREVIEW (standards.iteh.ai)

[ISO 20176:2011](https://standards.iteh.ai/catalog/standards/sist/5c7884e5-a11a-474b-899c-1e8d9cff27ed/iso-20176-2011)

<https://standards.iteh.ai/catalog/standards/sist/5c7884e5-a11a-474b-899c-1e8d9cff27ed/iso-20176-2011>

Road vehicles — H-point machine (HPM-II) — Specifications and procedure for H-point determination

1 Scope

This International Standard provides the specifications and procedures for using the H-point machine (HPM)¹⁾ to audit vehicle seating positions. The HPM is a physical tool used to establish key reference points and measurements in a vehicle. The H-point design tool (HPD) is a simplified computer-aided design (CAD)²⁾ version of the HPM, which can be used in conjunction with the HPM to take the optional measurements specified in this International Standard, or used independently during product design.

These H-point devices provide a method for reliable layout and measurement of occupant seating compartments or seats. This International Standard specifies the procedures for installing the H-point machine (HPM) and using the HPM to audit (verify) key reference points and measurements in a vehicle.

The devices are intended for application at designated seating positions. They are not to be construed as tools that measure or indicate occupant capabilities or comfort. They are not intended for use in defining or assessing temporary seating, such as folding jump seats.

2 Normative references

The following referenced documents are indispensable for the application of this document. For dated references, only the edition cited applies. For undated references, the latest edition of the referenced document (including any amendments) applies.

ISO 4130, *Road vehicles — Three-dimensional reference system and fiducial marks — Definitions*

SAE J1100, *Motor vehicle dimensions*

SAE J4002, *H-point machine (HPM-II) specifications and procedure for H-point determination — Auditing vehicle seats*

3 Terms and definitions

For the purposes of this document, the terms and definitions given in SAE J1100 and the following apply.

3.1

H-point

point at the pivot centre of the back pan and cushion pan assemblies, located on the lateral centreline of the H-point device

1) All references to H-point machine or HPM in this International Standard refer to the SAE J4002 H-point machine (HPM-II), unless otherwise noted.

2) CAD has come to encompass any software system or approach to automotive design and development, and is often used to refer to CAE (computer-assisted engineering) and CAM (computer-assisted manufacturing) software systems as well.

NOTE 1 The H-point device can be the H-point machine (HPM) or the H-point design tool (HPD).

NOTE 2 The H-point is also the intersection of the cushion line and the torso line. When an H-point device is properly positioned within a vehicle, either in CAD or in an actual physical property, the location of the H-point relative to the vehicle is used as a vehicle reference point. If the seat is moved, the location of the H-point within the vehicle is changed. Therefore, adjustable seats have more than one H-point location, while fixed seats have only one H-point location.

NOTE 3 H-points are often referred to as hip points or hip pivot points. They simulate, but do not precisely represent, the location of the human hip joint.

3.2
H-point travel path
all possible locations of the H-point provided by the full range of seat adjustments (horizontal, vertical or tilt) for a given designated seating position

3.3
seating reference point
SgRP
R-point
manufacturer's intended location for a design H-point, which is specifically designated as R-point or SgRP, and which:

- a) is the fundamental reference point used to establish occupant accommodation tools and dimensions;
- b) simulates the position of the pivot centre of the human torso and thigh;
- c) has coordinates established with respect to the designed vehicle structure;
- d) establishes the rearmost normal design driving or riding H-point of each designated seating position, which accounts for all modes of adjustment, horizontal, vertical and tilt that are available for the seat, but does not include seat travel used for purposes other than normal driving and riding

NOTE The SgRP is sometimes referred to as the design H-point.

3.4
accelerator heel point
AHP
point representing the heel of shoe location on the depressed floor covering, when the bottom of shoe is in contact with the undepressed accelerator pedal and the ankle angle is at 87°

NOTE The lateral location (y-coordinate) is aligned with the BOFRP unless shoe interference with side support structure causes an offset of the AHP from the BOFRP (see 5.1.4.2).

3.5
ball of foot reference point
BOFRP
point representing the ball of foot location on the shoe plane when the H-point machine shoe is set to a specified shoe plane angle, the bottom of shoe is in contact with the undepressed accelerator pedal, the ball of foot is aligned with the lateral centreline of the undepressed accelerator pedal in rear view, and the heel of shoe is at the depressed floor covering

NOTE The BOFRP and AHP are at the same y-coordinate unless there is lateral shoe interference.

3.6
floor reference point, rear passenger
FRP
point at the intersection of the heel of shoe and the depressed floor covering, with the bottom of shoe resting on the depressed floor covering

NOTE FRP is determined within 127 mm to either side of centreline of occupant, with the shoe or lower leg segment moved forward to rest against the seat in front (contacting the underseat structure, lower portion of the seat back trim, etc.).

3.7**lumbar support prominence****LSP**

measure of the back pan shape imposed on the HPM by the contour of the lower seatback

See Table A.4.

3.8**shoe plane angle****SPA**
 α_{SP}

angle from horizontal to the bottom of the HPM shoe when the shoe is in contact with the undepressed accelerator pedal and the shoe heel is at the AHP

NOTE SPA is provided by the vehicle manufacturer or calculated from the manufacturer's published seat height H30-1 (see 5.1.4).

4 Measurement procedure for the three-dimensional H-point machine**4.1 General**

A complete description of the three-dimensional H-point machine is given in Annex A (see Figure 1). Specifications and tolerances are given in Annex B. A field checking procedure for the HPM is given in Annex C.

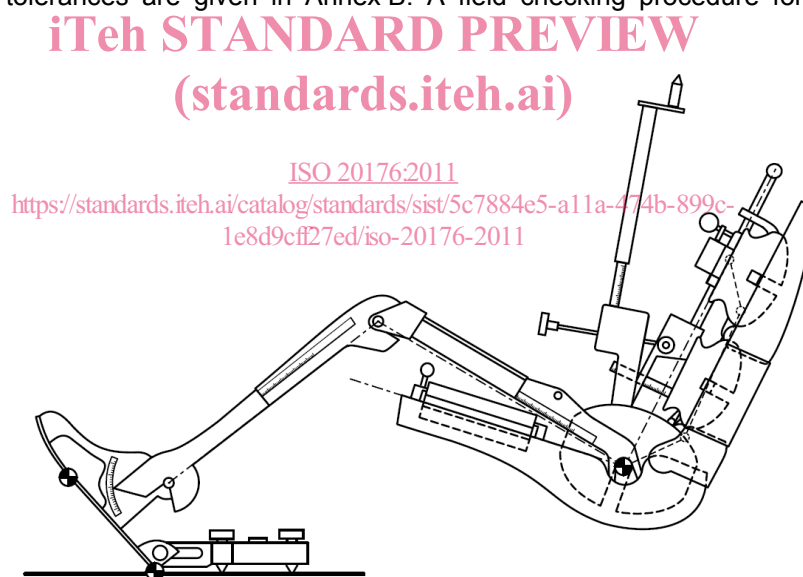

Figure 1 — Side view of HPM, including optional components

The HPM includes divot points that can be used by a coordinate measuring machine (CMM) and in CAD to fully define the location of the machine in the vehicle space (see A.2.3). Calibrated planar surfaces on the HPM facilitate field measurement of machine angles using an inclinometer. A scale readout indicates the lumbar support prominence (LSP) value. An ankle angle scale is provided to aid HPM installation in long-coupled passenger seating.

Several of the reference points established with an H-point device are required for the subsequent positioning of other design devices, such as head contours, eyellipses, and reach curves. The most important reference points established by an H-point device are the H-point, the H-point travel path, the seating reference point (SgRP), the accelerator heel point (AHP), and the ball of foot reference point (BOFRP). These reference points are illustrated in Figure A.8.

4.2 Summary of installation procedure

4.2.1 Summary

See Table 1.

Table 1 — Summary of installation procedure

Driver position	Passenger positions: 2nd and 3rd row
Prepare the physical property. If possible, calibrate the CMM equipment to vehicle grid coordinates	
Position seat to design intent location and attitude	Position the test seat and (if the HPM legs are to be installed) the seat in front of the test seat to design intent location and attitude
Install shoe fixture and shoe tool, if measuring leg and shoe dimensions. Record shoe-based measurements. See 5.1	Install shoe tool, if measuring leg and shoe dimensions. Record shoe-based measurements. See 6.1
Install and load the cushion pan, and back pan. If measuring headroom, install headroom fixture before loading the pans. See 7.1. Determine H-point, torso angle, cushion angle, and LSP. See 4.8	
Attach thigh and lower leg segments, if measuring leg-based dimensions. See 5.1	Attach thigh and lower leg segments, if measuring leg-based dimensions. See 6.1
Determine optional measurements. See 5.2 and 7.1	Determine optional measurements. See 6.2 and 7.1

ITeH STANDARD PREVIEW
(standards.iteh.ai)

4.2.2 Measured versus design values

When verifying or auditing a particular designated vehicle seating position, measurements taken with the three-dimensional HPM are normally compared to the design values indicated by the vehicle manufacturer. If any measured value is sufficiently close to the manufacturer's design value, the vehicle or seat is considered to meet the manufacturer's design intent for that measurement. The vehicle manufacturer or a regulatory agency may provide specifications for the term "sufficiently close". Two HPM measurements of particular interest are H-point (SgRP) and torso angle.

4.3 Prepare vehicle and seat

4.3.1 Vehicle

Dimensions shall be measured relative to the vehicle three-dimensional reference system by setting up the vehicle relative to the fiducial marks in accordance with ISO 4130 as specified by the manufacturer. The vehicle (or seating buck) shall be levelled prior to any HPM installation or measurement. Once the vehicle is levelled, care should be taken to not lean on it, rock it, or in some other way knock it off level.

If the accelerator pedal is needed for the measurements, the accelerator pedal shall be held in an undepressed position by some means. For example, use blocks or clamp the accelerator cable to prevent the pedal from moving. If the pedal rotates about a pivot, independent of throttle movement, do not restrict that motion. If the accelerator pedal has fore/aft adjustment, the pedal shall be positioned as specified by the manufacturer. If no specification is provided, the pedal shall be adjusted to its most forward position in the vehicle.

4.3.2 Seat

The vehicle shall be preconditioned at the manufacturer's discretion, at a temperature of 19 °C to 26 °C to ensure that the seat material reaches room temperature. Room relative humidity should be within 50 % ± 5 %. If this relative humidity is not met, record both relative humidity and room temperature

The following considerations are to help ensure that stable, reliable measurements are made across seat types. If the seat to be checked has never been sat upon, a 70 kg to 80 kg person or device shall be placed on the seat to flex the cushion and back. Prior to the installation of the HPM, seats should remain unloaded for 30 min at the manufacturer's request. This is to allow the seat and seat materials (e.g. foam) to recover from compression.

Muslin cloth should be placed over the seat prior to installing the HPM. The muslin cloth may be a single piece fitting across both seat cushion and seat back, or two pieces, one for the cushion and one for the seat back. This ensures a constant friction surface across seat fabrics. See B.11.

When using the HPM, interactions can occur between adjacent seating positions (i.e. having an HPM installed at the centre occupant position can change the results obtained for the outboard occupant position). Therefore, only one machine should be installed in a particular row of seats during each test.

4.4 Determine the H-point travel path (optional)

If verification of the H-point travel path is desired, the seat's travel path shall be digitized and then translated to the H-point travel path. First, adjust the seat cushion to the middle of the cushion angle adjustment range. Next, place one or more registration marks on the side of the seat. The registration mark(s) can be located anywhere along the side of the seat that can be easily accessed by the CMM equipment. Finally, digitize the location of the registration mark(s) with the seat in each of four positions: lowest most-rearward, highest most-rearward, highest most-forward, lowest most-forward. By connecting these four points, the seat's travel path can be seen more readily. See Figure 2 a) and b).

NOTE For seats without vertical adjustment, only two points need to be taken, most forward and most rearward, provided the seat track follows a linear path. If the seat track travel path is curved, additional points (between foremost and rearmost) need to be taken.

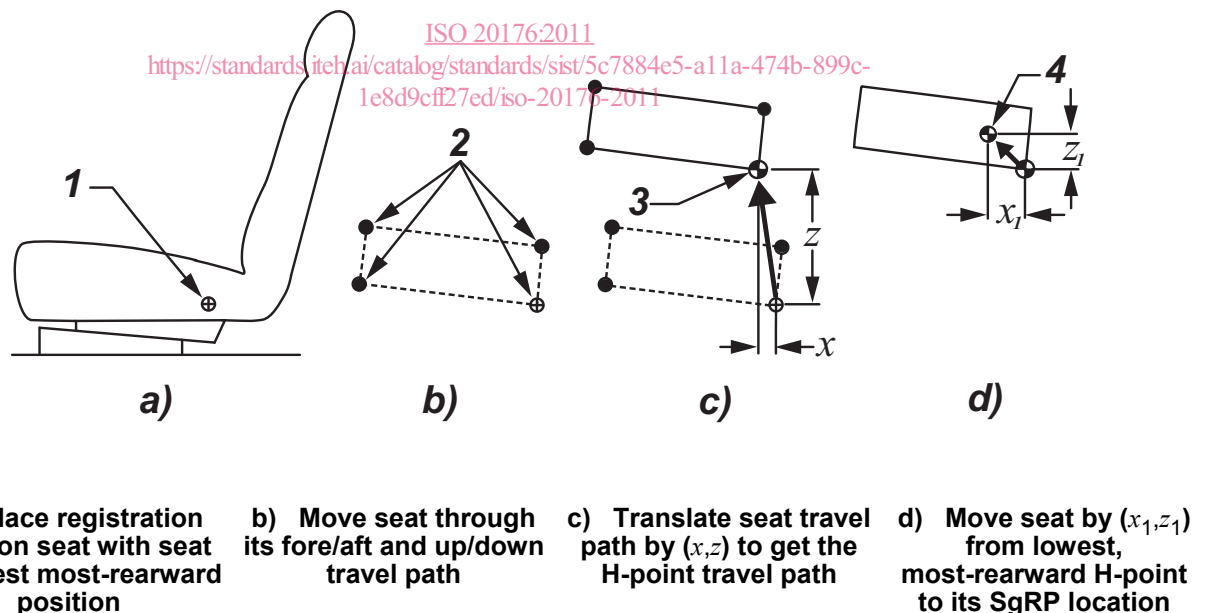

Key

- 1 registration mark
- 2 registration mark at extremes of seat travel
- 3 lowest, most-rearward H-point
- 4 SgRP

Figure 2 — Locating seating reference point from the seat travel path

4.5 Adjust seat to design intent

4.5.1 Move seat to design intent position

All adjustable features of the seat shall be set to manufacturer's design intent attitude or position before installing the HPM.

For seats with an independent vertical adjustment or suspension, the vertical position shall be rigidly fixed in a position specified by the manufacturer.

The seat registration mark is helpful in positioning the seat at design intent relative to one of the seat's extreme locations (usually the rearmost, lowest position) determined in 4.4. Normally, the design intent position specified by the vehicle manufacturer is the SgRP. Figure 2 illustrates a typical way to translate seat travel to H-point travel, and then to SgRP. After an adjustable seat is positioned at design intent, digitize the seat registration mark(s).

4.5.2 Torso angle and cushion angle

4.5.2.1 General

Seat torso and cushion angle adjustment procedures for auditing differ depending on whether or not variance in seat build is of interest.

4.5.2.2 Standard audit: include seat and vehicle build variability

The seat shall be adjusted to the design intent torso angle and cushion angle before installing the HPM. The vehicle manufacturer (or seat supplier) shall provide information regarding the location and attitude of the discernable seat structure (e.g. the seat frame), other hard points (e.g. seat controls, pivot points, head restraint rods), or the amount of adjustment required to attain the desired seat attitude.

4.5.2.3 Optional audit: exclude seat build variability

If the purpose of the audit is to evaluate the build of the vehicle package without accounting for seat build variability, then the HPM needs to be installed in order to set the seat to the design intent values of torso and cushion angles.

As the HPM is loaded with weights, torso angle tends to increase and cushion angle tends to decrease. If torso and cushion angles are adjustable, the initial (unloaded) angles usually differ by about 1° to 2° from the desired final angles after loading. For example, set the seat back initially to an angle of approximately 20° to achieve a final torso angle of 22°.

Monitor and readjust torso and cushion angles as necessary during installation of HPM weights in order to achieve the design intent angles as the final reading (see Table 2). Then, remove the HPM, wait 30 min to allow the seat materials to recover, and install the HPM a second time for the audit. For this audit, the HPM installation normally includes the leg and shoe tool, as well as the headroom fixture.

NOTE The seat can also be audited independently of the vehicle.

Table 2 — Optional audit: Adjusting torso and cushion angles during HPM loading

Angle	Driver position	Passenger positions: 2nd or 3rd row
Torso angle A40	Initially set the torso angle to approximately 2° more vertical than design intent. Monitor and adjust if needed during HPM loading to achieve design intent	If the seat recliner is adjustable, initially set the torso angle to approximately 2° more vertical than design intent. Monitor and adjust if needed during HPM loading to achieve design intent
Cushion angle A27	If the seat cushion is adjustable, initially set the cushion angle to be slightly greater than design intent value. Monitor and readjust as necessary during HPM installation to achieve the design intent cushion angle as the final reading	

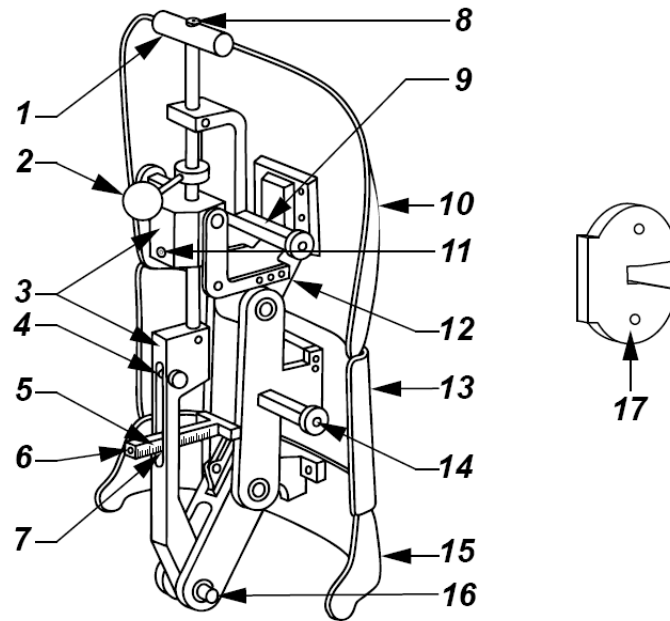

Key

1	handle	10	thoracic segment
2	torso articulation locking lever	11	B2 divot
3	inclinometer lands for torso angle	12	articulation mechanism
4	head room fixture tumbler	13	lumbar segment
5	lumbar support prominence (LSP) scale	14	lower weight rack (left side)
6	load application point	15	pelvic segment
7	indicator to read LSP value	16	H-point pivot shaft
8	B1 divot	17	one of twelve back weights
9	upper weight rack (left side)		

Figure 3 — Back pan

4.5.3 Seat in front of test seat

If leg positions, legroom, footroom, and knee clearance are to be measured, the seat in front of the test seat should be positioned to its SgRP and design intent torso angle.

4.6 Install HPM cushion and back pan assembly

4.6.1 Install the cushion pan

Place the cushion pan (see Figure 4) on the seat with the back of the pan resting lightly against the seat back. Visually centre the cushion pan laterally in the seat.

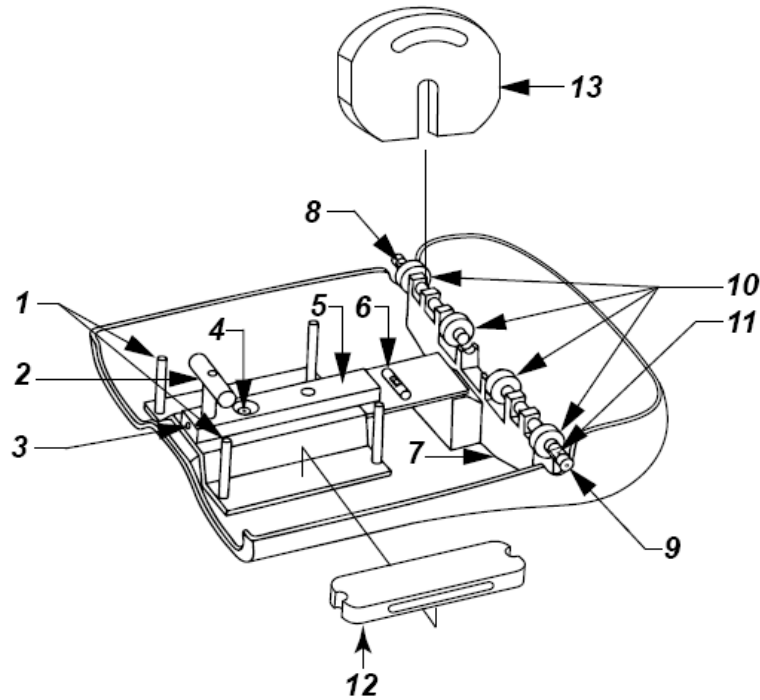

Key

- 1 thigh weight locating pins (4)
- 2 handle
- 3 load application point
- 4 C1 divot
- 5 inclinometer land for cushion angle
- 6 lateral level
- 7 H-point saddle
- 8 H1R divot
- 9 H1L divot
- 10 locking bushings for attaching back pan (2), thigh segment (2) and headroom fixture
- 11 H2L divot
- 12 thigh weight (6)
- 13 pelvic weight (6)

iTeh STANDARD PREVIEW
(standards.iteh.ai)

ISO 20176:2011
<https://standards.iteh.ai/catalog/standards/sist/5c7884e5-a11a-474b-899c-1e8d9cff27ed/iso-20176-2011>

Figure 4 — Cushion pan

4.6.2 Install the back pan

To protect the shells of the cushion and back pans, the back pan should be locked in a slouched position before installing it. Articulate the back pan into a slouched position (LSP < 0) and lock.

Place the H-point pivot shaft, located at the base of the back pan, on the H-point saddle of the cushion pan (see Figures 3 and 4). The upper portions of the back pan should not contact the seat back. Secure by sliding the brass locking bushings inwards over the H-point shaft.

Unlock the torso articulation. Put one hand firmly on the cushion pan T-handle to maintain the position of the cushion pan. Put the other hand on the back pan T-handle and gently rotate the back pan assembly against the seat back to allow the back pan assembly to conform to the seat back contour. Ensure that the top and bottom corners at each side of the lumbar segment remain outside the thoracic and pelvic segments. Also ensure that the muslin cloth is not caught between the back segments (see Figure 5).

The cushion and back pan can be connected and installed as a single unit if preferred. Follow the same steps as above, centring the cushion pan lightly against the seat back with the back pan rotated forward and locked in the slouched position.

If measuring headroom, install the headroom fixture now (see 7.1).

4.6.3 Level the HPM

Referring to the bubble level on the cushion pan, dither and adjust the HPM so it is level laterally on the seat. Make sure the HPM is in firm contact with the seat back.

4.7 Load the HPM

4.7.1 Procedure

Installing weights on the HPM is referred to as 'loading'. The HPM shall be loaded with the torso articulation mechanism unlocked. Weights shall be installed from the H-point outward and from the H-point upward to prevent the HPM from toppling out of the seat. Prior to each round of weights being loaded, an 89 N force shall be applied twice by 'punching' the appropriate load application site with the spring-loaded probe. The operator shall immediately release any applied force once the punch probe reaches its spring loading. This procedure ensures the HPM remains fully nested into the seat during the loading.

4.7.2 Summary table

The HPM shall be checked for level during the loading process. The sequence of actions for loading the HPM, summarized in Table 3, shall be followed.

Table 3 — Loading the HPM

Round	Apply 89 N	Load two weights	Then load two weights	Check for:
1	Punch twice (cushion)	2 Pelvic — innermost positions	2 Thigh	Level
2	Punch twice (cushion)	2 Pelvic — next innermost positions	2 Thigh	Level
3	Punch twice (cushion)	2 bevelled Pelvic — outermost positions	2 Thigh	Level
4	Punch twice (back)	2 Lower rack — innermost positions	2 Upper rack — innermost positions	Level
5	Punch twice (back)	2 Lower rack — next innermost position	2 Upper rack — next innermost positions	Level
6	Punch twice (back)	2 Lower rack — outermost positions	2 Upper rack — outermost positions	Level
7	Lock torso articulation			

4.7.3 Load the cushion pan

There are two types of weights for loading the cushion pan; pelvic weights, which are positioned in slots along the H-point axis, and thigh weights that are held in place by the pins in the thigh area.

Punch the HPM twice at the cushion pan load application point (see Figure 5). Install two pelvic weights in the innermost pelvic weight slots (one to either side of the H-point). Install two thigh weights (one to either side). Check for level.

Repeat these steps (punch twice, load two pelvic weights, load two thigh weights, and level) two more times to complete the loading of the cushion pan.