**Road vehicles — Tachograph systems —
Part 1:
Electrical connectors**

*Véhicules routiers — Systèmes tachygraphes —
Partie 1: Connecteurs électriques*

**iTeh STANDARD PREVIEW
(standards.iteh.ai)**

[ISO 16844-1:2013](https://standards.iteh.ai/catalog/standards/sist/a64af796-c2d8-4e5b-a829-4c0291fc6ffd/iso-16844-1-2013)

<https://standards.iteh.ai/catalog/standards/sist/a64af796-c2d8-4e5b-a829-4c0291fc6ffd/iso-16844-1-2013>



iTeh STANDARD PREVIEW
(standards.iteh.ai)

ISO 16844-1:2013

<https://standards.iteh.ai/catalog/standards/sist/a64af796-c2d8-4e5b-a829-4c0291fc6ffd/iso-16844-1-2013>



COPYRIGHT PROTECTED DOCUMENT

© ISO 2013

All rights reserved. Unless otherwise specified, no part of this publication may be reproduced or utilized otherwise in any form or by any means, electronic or mechanical, including photocopying, or posting on the internet or an intranet, without prior written permission. Permission can be requested from either ISO at the address below or ISO's member body in the country of the requester.

ISO copyright office
Case postale 56 • CH-1211 Geneva 20
Tel. + 41 22 749 01 11
Fax + 41 22 749 09 47
E-mail copyright@iso.org
Web www.iso.org

Published in Switzerland

Contents

	Page
Foreword	iv
Introduction	v
1 Scope	1
2 Normative references	1
3 Dimensions	1
4 Contact allocation	3
4.1 Standard connector.....	3
4.2 Optional connector.....	4
5 Performance — Tests and requirements	5
5.1 General.....	5
5.2 Temperature/humidity cycling.....	5
5.3 Combined temperature/vibration.....	6
5.4 Dielectric strength.....	6
5.5 Mechanical shock and chemical fluids.....	6
Bibliography	7

iTeh STANDARD PREVIEW (standards.iteh.ai)

[ISO 16844-1:2013](https://standards.iteh.ai/catalog/standards/sist/a64af796-c2d8-4e5b-a829-4c0291fc6ffd/iso-16844-1-2013)

<https://standards.iteh.ai/catalog/standards/sist/a64af796-c2d8-4e5b-a829-4c0291fc6ffd/iso-16844-1-2013>

Foreword

ISO (the International Organization for Standardization) is a worldwide federation of national standards bodies (ISO member bodies). The work of preparing International Standards is normally carried out through ISO technical committees. Each member body interested in a subject for which a technical committee has been established has the right to be represented on that committee. International organizations, governmental and non-governmental, in liaison with ISO, also take part in the work. ISO collaborates closely with the International Electrotechnical Commission (IEC) on all matters of electrotechnical standardization.

International Standards are drafted in accordance with the rules given in the ISO/IEC Directives, Part 2.

The main task of technical committees is to prepare International Standards. Draft International Standards adopted by the technical committees are circulated to the member bodies for voting. Publication as an International Standard requires approval by at least 75 % of the member bodies casting a vote.

Attention is drawn to the possibility that some of the elements of this document may be the subject of patent rights. ISO shall not be held responsible for identifying any or all such patent rights.

ISO 16844-1 was prepared by Technical Committee ISO/TC 22, *Road vehicles*, Subcommittee SC 3, *Electrical and electronic equipment*.

This second edition cancels and replaces the first edition (ISO 16844-1:2001), which has been technically revised. It also incorporates the Technical Corrigendum ISO 16844-1:2001/Cor.1:2005.

ISO 16844 consists of the following parts, under the general title *Road vehicles — Tachograph systems*:

— *Part 1: Electrical connectors*

— *Part 2: Electrical interface with recording unit*

— *Part 3: Motion sensor interface*

— *Part 4: CAN interface*

— *Part 5: Secured CAN interface*

— *Part 6: Diagnostics*

— *Part 7: Parameters*

ITEN STANDARD PREVIEW
(standards.iten.ai)

ISO 16844-1:2013
<https://standards.iten.ai/catalog/standards/sist/a64af796-c2d8-4e5b-a829-4c0291fc6ffd/iso-16844-1-2013>

Introduction

ISO 16844 supports and facilitates the communication between electronic units and a tachograph; the tachograph being based upon Council Regulations (EC) No. 561/2006^[1] and (EEC) No. 3821/85 as last amended.^[2]

The purpose of this part of ISO 16844 is to ensure the compatibility of tachographs from various tachograph manufacturers.

The basis of the digital tachograph concept is a recording unit (RU) that stores data related to the activities of the drivers of a vehicle on which it is installed. When the RU is in normal operational status, the data stored in its memory are made accessible to various entities such as drivers, authorities, workshops, and transport companies in a variety of ways: they may be displayed on a screen, printed by a printing device, or downloaded to an external device. Access to stored data is controlled by a smart card inserted in the tachograph.

In order to prevent manipulation of the tachograph system, the speed signal sender (motion sensor) is provided with an encrypted data link.

A typical tachograph system is shown in [Figure 1](#).

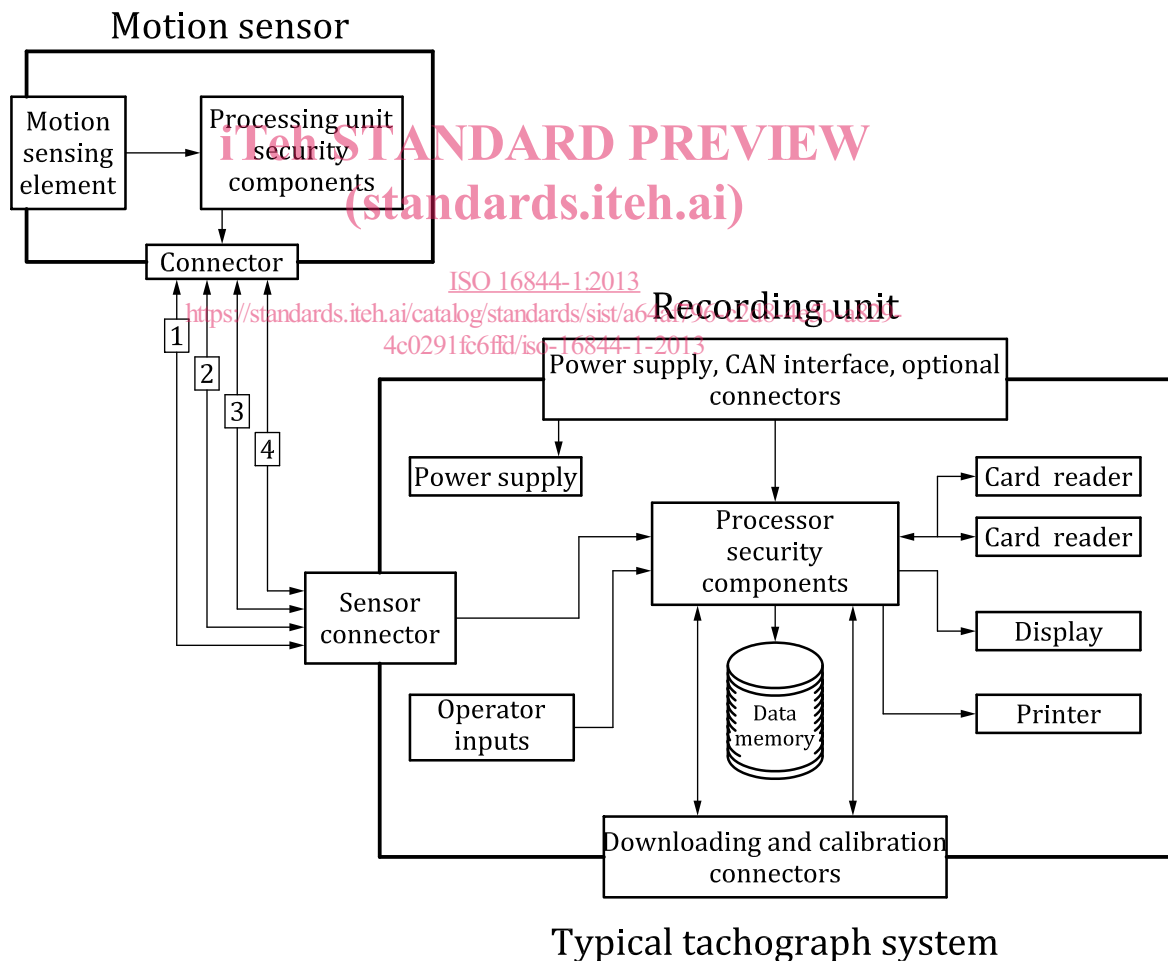

Key

- | | |
|-------------------|---------------------------|
| 1 positive supply | 3 speed signal, real time |
| 2 battery minus | 4 data signal in/out |

Figure 1 — Typical tachograph system

iTeh STANDARD PREVIEW
(standards.iteh.ai)

[ISO 16844-1:2013](https://standards.iteh.ai/catalog/standards/sist/a64af796-c2d8-4e5b-a829-4c0291fc6ffd/iso-16844-1-2013)

<https://standards.iteh.ai/catalog/standards/sist/a64af796-c2d8-4e5b-a829-4c0291fc6ffd/iso-16844-1-2013>

Road vehicles — Tachograph systems —

Part 1: Electrical connectors

1 Scope

This part of ISO 16844 gives the dimensions and tests and requirements for the performance of electrical connectors needed for ensuring the interchangeability of different components of the tachograph systems used for road vehicles in accordance with Council Regulation (EEC) No. 3821/85 on recording equipment in road transport. In particular, this part of ISO 16844 specifies the connectors used to connect the recording unit of the tachograph to the vehicle electrical wiring harness.

2 Normative references

The following documents, in whole or in part, are normatively referenced in this document and are indispensable for its application. For dated references, only the edition cited applies. For undated references, the latest edition of the referenced document (including any amendments) applies.

ISO 8092-2:2005, *Road vehicles — Connections for on-board electrical wiring harnesses — Part 2: Definitions, test methods and general performance requirements*

3 Dimensions

The connectors used to connect the recording unit shall conform with [Figure 2](#).

Details not specified are left to the manufacturer's choice.

The standard connector (parts A and B) shall be used, while C and D are optional. The connector parts may be parted from each other at the manufacturer's discretion.

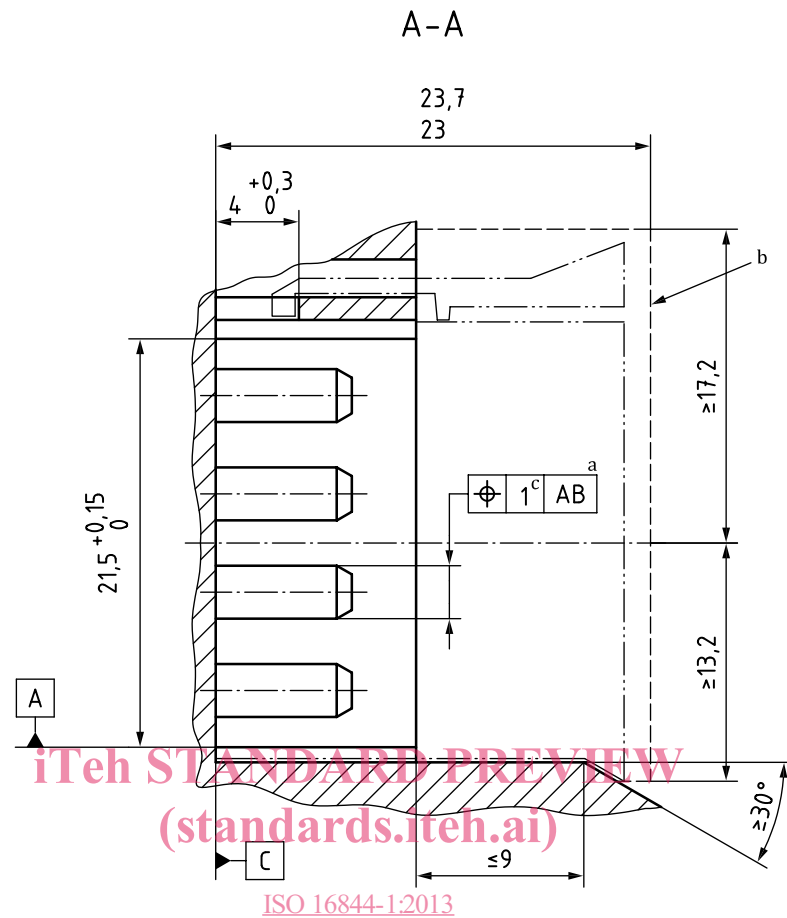

- a All tabs. <https://standards.iteh.ai/catalog/standards/sist/a64af796-c2d8-4e5b-a829-4c0291fc6ffd/iso-16844-1-2013>
- b Requested space for socket housing (space for disconnection and cable not shown).
- c Linear increase from 0,12 at the level of datum plane "C" up to 0,4 at the top of the tabs.

Figure 3 — Section A-A (see Figure 2)

4 Contact allocation

4.1 Standard connector

The contact allocation of the standard connector, parts A and B, shall be as shown in Figure 4 and as given in Table 1.