



# Standard Test Method for Determining the Chemical Resistance of Fiberglass- Reinforced Thermosetting Resins by One-Side Panel Exposure<sup>1</sup>

This standard is issued under the fixed designation D 4398; the number immediately following the designation indicates the year of original adoption or, in the case of revision, the year of last revision. A number in parentheses indicates the year of last approval. A superscript epsilon ( $\epsilon$ ) indicates an editorial change since the last revision or reapproval.

## 1. Scope\*

1.1 This test method is intended for use in the evaluation of the chemical resistance of fiberglass-reinforced thermosetting resins that are subjected to one-side panel exposure to specific environments. It takes into consideration the coldwall effects and radiation losses of heat transfer through the laminate wall.

1.2 This test method is supplemental to Practice C 581 and does not supersede it.

NOTE 1—There is no similar or equivalent ISO standard.

1.3 *This standard does not purport to address all of the safety problems, if any, associated with its use. It is the responsibility of the user of this standard to establish appropriate safety and health practices and determine the applicability of regulatory limitations prior to use.*

## 2. Referenced Documents

### 2.1 ASTM Standards:

C 581 Practice for Determining Chemical Resistance of Thermosetting Resins Used in Glass Fiber Reinforced Structures Intended for Liquid Service<sup>2</sup>

D 790 Test Methods for Flexural Properties of Unreinforced and Reinforced Plastics and Electrical Insulating Materials<sup>3</sup>

D 2583 Test Method for Indentation Hardness of Rigid Plastics by Means of a Barcol Impressor<sup>4</sup>

## 3. Terminology

### 3.1 Definitions of Terms Specific to This Standard:

3.1.1 *glass fiber*—glass filaments for engineering applications, chiefly of a so-called "E" type made from a lime-alumina borosilicate glass that is relatively soda free, of high

strength-to-weight ratio. Glass fibers are used commercially in the reinforcement of rigid engineering plastic structures.

3.1.2 *thermosetting resins*—linear, relatively low molecular weight thermoplastic polymer chains with "crosslinks" which bond the chains together with primary valence bonds. Once cross-linked, such three-dimensional polymers will not soften up appreciably to their decomposition temperature. Typical of such resin systems are the polymers, vinyl esters, and epoxies.

## 4. Significance and Use

4.1 The results obtained by this test method may serve as a guide in, but not as the sole basis for, predicting the possible performance of the particular glass-fiber-reinforced thermosetting resin laminate in the one-side exposure to the specific environment under evaluation. No attempt has been made to incorporate into the test method all of the factors that may enter into the serviceability of a glass-fiber-reinforced resin structure when subjected to chemical environments.

4.2 This test method provides for the determination of changes in the physical properties of the test panel and test media during and after the one-side exposure in the test media. Determination of changes include: Barcol hardness, appearance of panel, appearance of test media, flexural properties, and thickness.

## 5. Apparatus

5.1 *Test Cell*—This is a laboratory unit in which only the surface of one side of a test panel is subjected to the corrosive or aggressive environment, which is the normal experience of chemical processing equipment in actual plant operations. It consists of an open-ended glass cylinder, with several ground-glass joint nozzles for insertion of appropriate auxiliaries. The ends of the open glass cylinder are closed off with the fiberglass-reinforced resin panel to be tested, and are tightly sealed with chemical-resistant gaskets, allowing one side of the panel to come in contact with the test media.

5.1.1 Typical test cells are shown in Fig. 1 and Fig. 2. Other laboratory units for one-side corrosion testing of equal or larger diameter may be used also with correspondingly appropriate panel sizes.

<sup>1</sup> This test method is under the jurisdiction of ASTM Committee D20 on Plastics and is the direct responsibility of Subcommittee D20.23 on Reinforced Plastic Piping Systems and Chemical Equipment.

Current edition approved March 10, 2002. Published May 2002. Originally published as D 4398 – 84. Last previous edition D 4398 – 95.

<sup>2</sup> *Annual Book of ASTM Standards*, Vol 08.04.

<sup>3</sup> *Annual Book of ASTM Standards*, Vol 08.01.

<sup>4</sup> *Annual Book of ASTM Standards*, Vol 08.02.

\*A Summary of Changes section appears at the end of this standard.

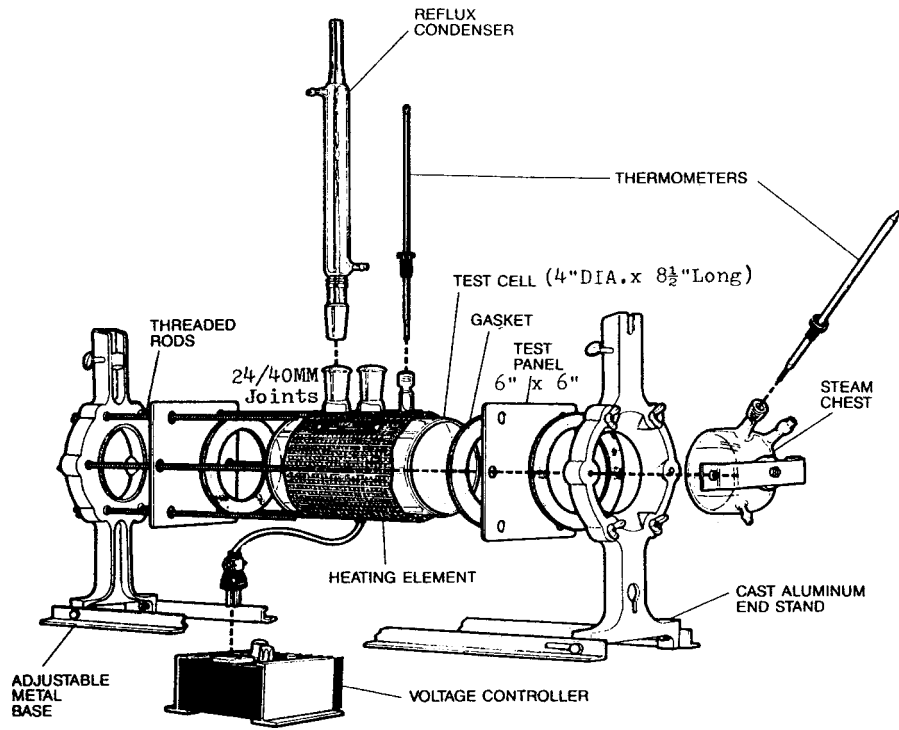

FIG. 1 Test Cells

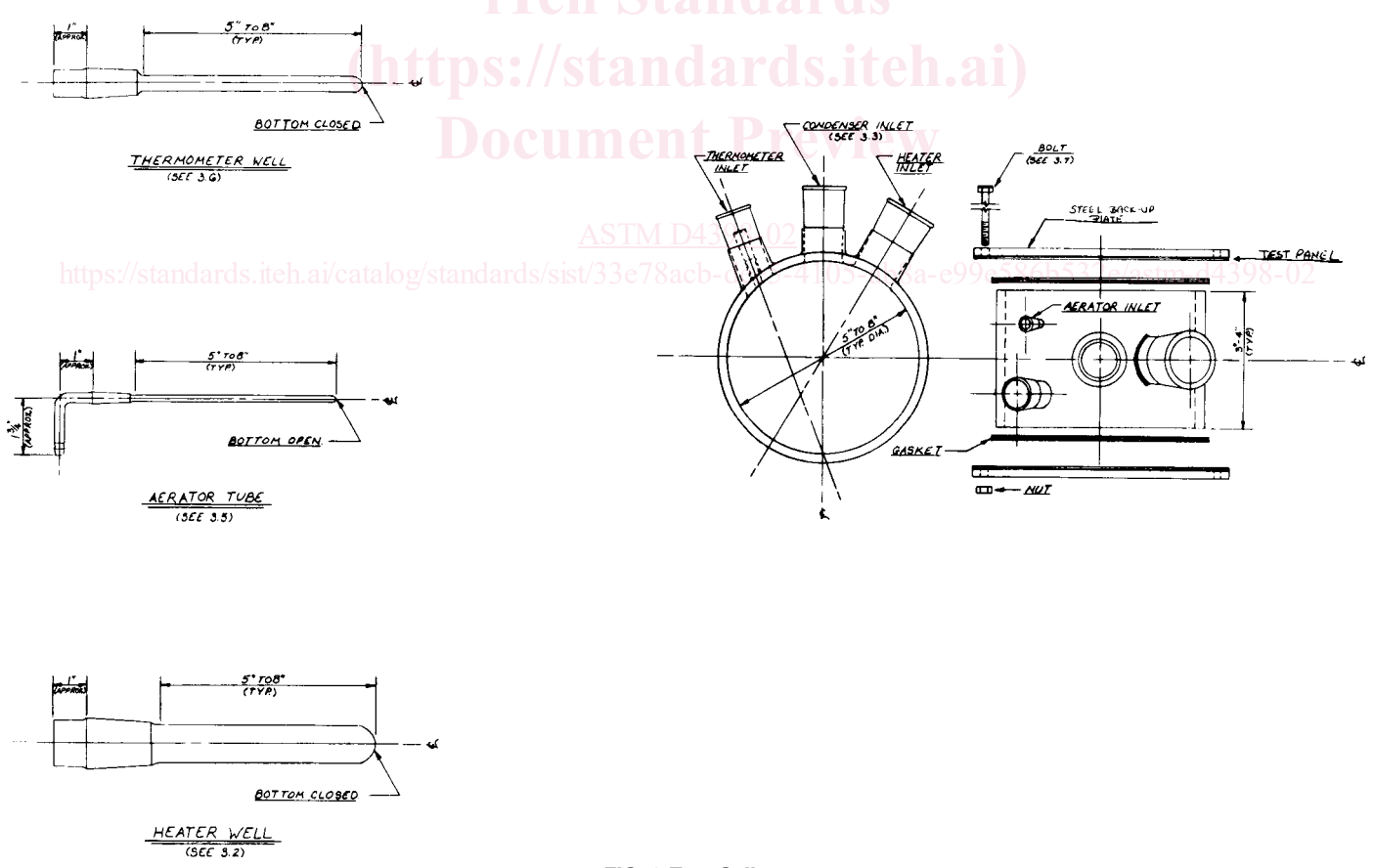

FIG. 2 Test Cells