**Hard coal — Determination of the
crucible swelling number**

Houille — Détermination de l'indice de gonflement au creuset

iTeh STANDARD PREVIEW
(standards.iteh.ai)

ISO 501:2012

<https://standards.iteh.ai/catalog/standards/sist/8addfb5f-7f0b-43d5-b9c5-fb63c39d4b25/iso-501-2012>



iTeh STANDARD PREVIEW
(standards.iteh.ai)

ISO 501:2012

<https://standards.iteh.ai/catalog/standards/sist/8addfb5f-7f0b-43d5-b9c5-fb63c39d4b25/iso-501-2012>



COPYRIGHT PROTECTED DOCUMENT

© ISO 2012

All rights reserved. Unless otherwise specified, no part of this publication may be reproduced or utilized in any form or by any means, electronic or mechanical, including photocopying and microfilm, without permission in writing from either ISO at the address below or ISO's member body in the country of the requester.

ISO copyright office
Case postale 56 • CH-1211 Geneva 20
Tel. + 41 22 749 01 11
Fax + 41 22 749 09 47
E-mail copyright@iso.org
Web www.iso.org

Published in Switzerland

Contents

Page

Foreword	iv
1 Scope	1
2 Normative references	1
3 Principle	1
4 Preparation of the test sample	1
5 Apparatus	1
6 Preparation of apparatus	3
7 Procedure	5
8 Expression of results	7
9 Precision of the method	7
9.1 Repeatability	7
9.2 Reproducibility	7
10 Test report	7

iTeh STANDARD PREVIEW (standards.iteh.ai)

ISO 501:2012

<https://standards.iteh.ai/catalog/standards/sist/8addfb5f-7f0b-43d5-b9c5-fb63c39d4b25/iso-501-2012>

Foreword

ISO (the International Organization for Standardization) is a worldwide federation of national standards bodies (ISO member bodies). The work of preparing International Standards is normally carried out through ISO technical committees. Each member body interested in a subject for which a technical committee has been established has the right to be represented on that committee. International organizations, governmental and non-governmental, in liaison with ISO, also take part in the work. ISO collaborates closely with the International Electrotechnical Commission (IEC) on all matters of electrotechnical standardization.

International Standards are drafted in accordance with the rules given in the ISO/IEC Directives, Part 2.

The main task of technical committees is to prepare International Standards. Draft International Standards adopted by the technical committees are circulated to the member bodies for voting. Publication as an International Standard requires approval by at least 75 % of the member bodies casting a vote.

Attention is drawn to the possibility that some of the elements of this document may be the subject of patent rights. ISO shall not be held responsible for identifying any or all such patent rights.

ISO 501 was prepared by Technical Committee ISO/TC 27, *Solid mineral fuels*, Subcommittee SC 5, *Methods of analysis*.

This fourth edition cancels and replaces the third edition (ISO 501:2003), which has been technically revised.

iTeh STANDARD PREVIEW
(standards.iteh.ai)

[ISO 501:2012](https://standards.iteh.ai/catalog/standards/sist/8addfb5f-7f0b-43d5-b9c5-fb63c39d4b25/iso-501-2012)

<https://standards.iteh.ai/catalog/standards/sist/8addfb5f-7f0b-43d5-b9c5-fb63c39d4b25/iso-501-2012>

Hard coal — Determination of the crucible swelling number

WARNING — Use of this International Standard can involve hazardous materials, operations and equipment. This International Standard does not purport to address all of the safety issues associated with its use. It is the responsibility of the user of this International Standard to establish appropriate safety and health practices and determine the applicability of regulatory limitations prior to use.

1 Scope

This International Standard specifies a method for determining the swelling properties of hard coal when heated in a covered crucible.

NOTE The “crucible swelling number” (CSN) is also known as the “free swelling index” (FSI).

2 Normative references

The following referenced documents are indispensable for the application of this document. For dated references, only the edition cited applies. For undated references, the latest edition of the referenced document (including any amendments) applies.

ISO 13909-4, *Hard coal and coke — Mechanical sampling — Part 4: Coal — Preparation of test samples*

ISO 18283, *Hard coal and coke — Manual sampling*

3 Principle

ISO 501:2012
<https://standards.iteh.ai/catalog/standards/sist/8addfb5f-7f0b-43d5-b9c5-fb63c39d4b25/iso-501-2012>

A sample of coal is heated in a covered crucible under standard conditions of time and temperature. The shape of the coke button obtained is classified by comparison with the outlines of a set of standard profiles.

4 Preparation of the test sample

The test sample shall be the general analysis test sample prepared in accordance with ISO 13909-4 and ISO 18283. Ensure that the moisture content of the sample is in equilibrium with the laboratory atmosphere, exposing it, if necessary, in a thin layer for the minimum time required to achieve equilibrium.

The sample used for the crucible swelling number (CSN) test should be ground to pass a 212 μm sieve. Avoid very fine grinding, as CSN can be adversely affected with pulverization level. Once the sample is prepared to this size specification, the test should be performed within 24 h in order to avoid oxidation and a potentially misleading CSN result.

5 Apparatus

5.1 Crucible and lid (see Figure 1): silica crucible, squat form, and silica lid with ring handle.

ISO 501:2012(E)

The crucible shall conform to the following specifications:

External height:	$26 \pm 1,0$ mm
External diameter at top:	$41 \pm 1,0$ mm
Internal diameter at base:	$14 \pm 3,0$ mm
Mass:	$12 \pm 1,0$ g
Capacity:	16 ml to 17,5 ml

Dimensions in millimetres

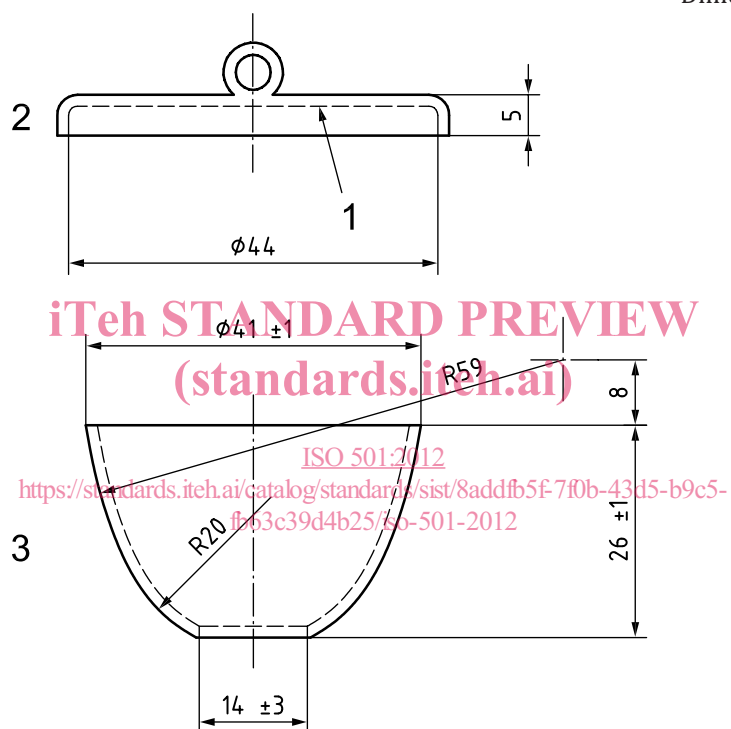

Key

- 1 flat surface required
- 2 lid
- 3 crucible

Figure 1 — Crucible with lid for swelling test

5.2 Pierced silica lid (see Figure 2), similar to that described in 5.1 but with a 6 mm hole through which the thermocouple (5.7) can pass.

Dimensions in millimetres

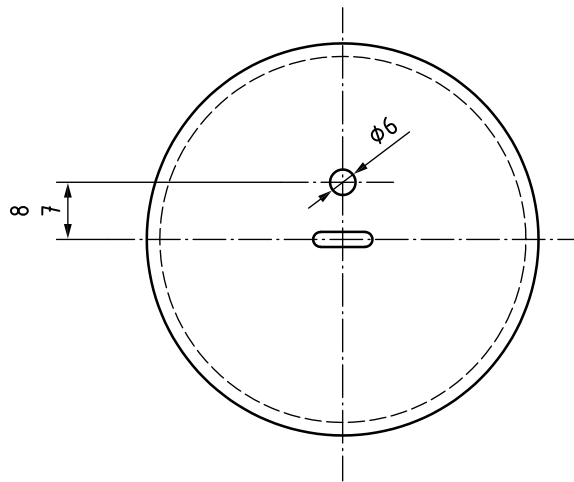

Figure 2 — Pierced crucible lid

5.3 Triangle, consisting of silica tubing of 6 mm to 6,5 mm external diameter, mounted on nickel/chromium wire, or formed of solid silica, the length of each side being approximately 55 mm to 60 mm.

5.4 Burner, capable of giving the required standard heating conditions.

For coal gas with a calorific value of approximately 20 MJ/m³, a Teclu-type burner having a burner tube with an internal diameter of approximately 12,5 mm has been found satisfactory. For natural gas or LPG with a calorific value of approximately 30 MJ/m³ to 40 MJ/m³, a Teclu or Meker-type burner could be used. For these types of gases, the diameter of the burner tube or burner grid should be approximately 30 mm.

Alternatively, an electrical heating system may be used, provided that it has been shown to give results within 1/2 unit of that obtained with the gas heating method over the whole range of swelling numbers.

5.5 Gauge, for measuring gas pressure.

5.6 Draught shield, made from refractory piping approximately 150 mm in length, of 100 mm internal diameter and 110 mm external diameter. At one end, the piping shall have three slots 25 mm deep in which the wire portions of the silica triangle rest (5.3) (see Figure 3).

5.7 Thermocouple, sheathed, of fine wire of diameter not greater than 0,5 mm if made of noble metals, or 0,8 mm if made of base metal.

5.8 Weight, of mass 500 g \pm 10 g.

5.9 Sight tube, made of any rigid and opaque material, for viewing the coke buttons, to avoid the effect of parallax (see Figure 4).

6 Preparation of apparatus

Assemble the apparatus as shown in Figure 3. Place an empty crucible (5.1) on the silica triangle (5.3) and support the crucible in the draught shield (5.6). Adjust the gas and air supplies to the burner (5.4), so that the temperature of the inner surface of the base of the crucible reaches 800 °C \pm 10 °C in 1,5 min and 820 °C \pm 5 °C in 2,5 min from first igniting the gas. Finally, heat a crucible in the apparatus for at least 5 min. Replace the crucible and check the temperatures again. Make any minor adjustments that are necessary to meet the standard conditions.

If a Teclu-type burner is used, a flame approximately 300 mm long, with the crucible positioned just above the tip of the blue cone, will generally be found to give the standard temperature conditions.

If a Meker-type burner is used, place the crucible approximately 10 mm above the burner grid and adjust the flame so that the standard temperature conditions are attained.

Measure the temperature using a thermocouple (5.7) inserted through the pierced lid (5.2) and having its unprotected junction and a portion of each wire in contact with the centre of the base of the empty crucible. A temperature of $800\text{ °C} \pm 10\text{ °C}$ should be attained after 1,5 min and one of $820\text{ °C} \pm 5\text{ °C}$ after 2,5 min.

Check the apparatus at frequent intervals to ensure that the standard conditions apply.

Dimensions in millimetres

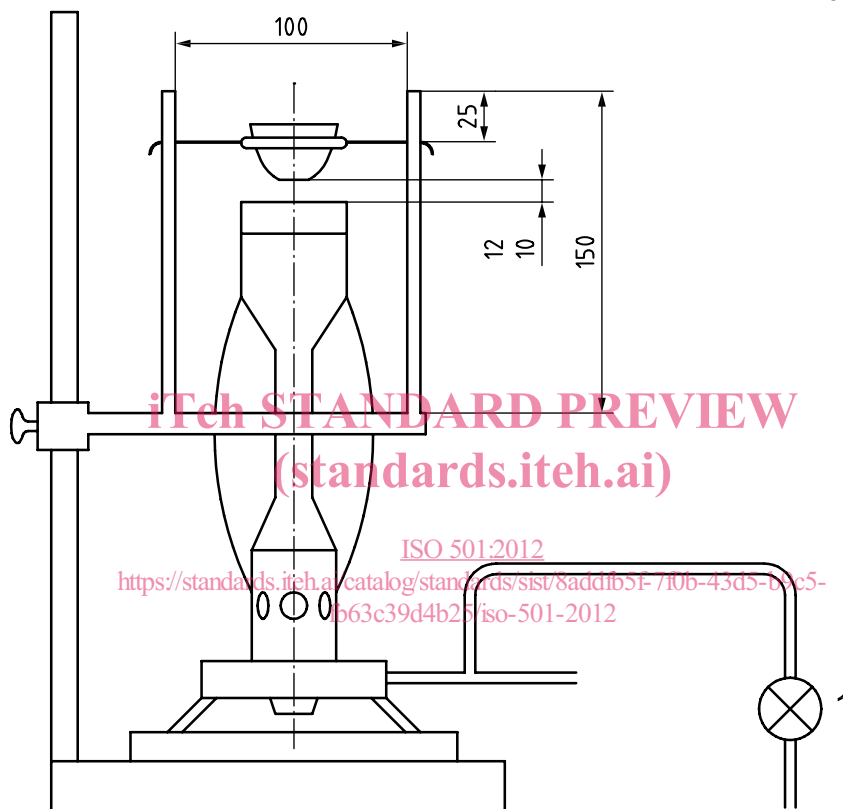

Key

- 1 pressure gauge graduated in kilopascals

Figure 3 — Apparatus for the gas heating method

Dimensions in millimetres

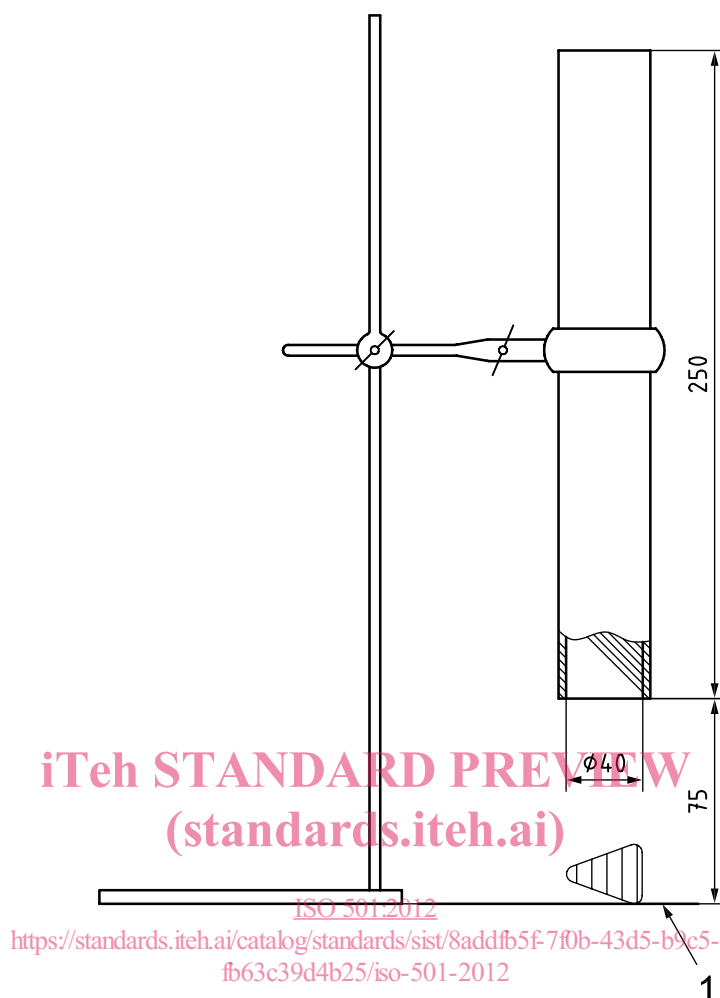
**Key**

- 1 standard profile template

Figure 4 — Sight tube apparatus

7 Procedure

Preheat the apparatus for approximately 5 min.

Weigh 1,00 g to 1,01 g of the freshly ground sample (see Clause 4) into a clean, dry crucible (5.1) and rotate the crucible if necessary while lightly tapping it 12 times on the bench to level the surface of the coal. Cover the crucible with the unpierced lid and place the crucible upright on the silica triangle (5.3), supported in the draught shield (5.6). Light the gas and heat at the predetermined rate for such time as is required for the flame of the burning volatile matter to die out, and in any case for at least 2,5 min. Turn off the gas and allow the crucible to cool.

Remove the residue carefully from the crucible.

Perform the test in triplicate.

If the residue is non-coherent, for example mostly loose powder, no further examination is needed and this result shall be designated as swelling number 0.

If the residue is a coherent coke button but is not swollen, place the button onto a flat surface and rest the 500 g weight (5.8) on the button. If the button supports the 500 g weight without breaking into more