



Designation: D1310 – 01 (Reapproved 2007)

Standard Test Method for Flash Point and Fire Point of Liquids by Tag Open-Cup Apparatus¹

This standard is issued under the fixed designation D1310; the number immediately following the designation indicates the year of original adoption or, in the case of revision, the year of last revision. A number in parentheses indicates the year of last reapproval. A superscript epsilon (ϵ) indicates an editorial change since the last revision or reapproval.

This standard has been approved for use by agencies of the Department of Defense.

1. Scope

1.1 This test method covers the determination by Tag Open-Cup Apparatus of the flash point and fire point of liquids having flash points between -18 and 165°C (0 and 325°F) and fire points up to 325°F .

1.2 This test method, when applied to paints and resin solutions that tend to skin over or that are very viscous, gives less reproducible results than when applied to solvents.

NOTE 1—In order to conserve time and sample, the fire point of a material may be determined by the Tag Open-Cup Method by continuing the heating of the specimen to its fire point. Fire points may also be determined by Test Method D92, which should be used for fire points beyond the scope of this test method.

1.3 The values stated in SI units are to be regarded as the standard. The values given in parentheses are for information only.

1.4 *This standard should be used to measure and describe the properties of materials, products, or assemblies in response to heat and flame under controlled laboratory conditions and should not be used to describe or appraise the fire hazard or fire risk of materials, products, or assemblies under actual fire conditions. However, results of this test may be used as elements of a fire risk assessment which takes into account all of the factors pertinent to an assessment of the fire hazard of a particular end use.*

1.5 *This standard does not purport to address the safety problems associated with its use. It is the responsibility of the user of this standard to establish appropriate safety and health practices and determine the applicability of regulatory limitations prior to use.*

¹ This test method is under the jurisdiction of ASTM Committee D01 on Paint and Related Coatings, Materials, and Applications and is the direct responsibility of Subcommittee D01.21 on Chemical Analysis of Paints and Paint Materials.

Current edition approved June 1, 2007. Published August 2007. Originally approved in 1952. Last previous edition approved in 2001 as D1310–01. DOI: 10.1520/D1310-01R07.

2. Referenced Documents

2.1 ASTM Standards:²

- D92 Test Method for Flash and Fire Points by Cleveland Open Cup Tester
- D850 Test Method for Distillation of Industrial Aromatic Hydrocarbons and Related Materials
- D1015 Test Method for Freezing Points of High-Purity Hydrocarbons
- D1016 Test Method for Purity of Hydrocarbons from Freezing Points
- D1078 Test Method for Distillation Range of Volatile Organic Liquids
- D1364 Test Method for Water in Volatile Solvents (Karl Fischer Reagent Titration Method)
- D2268 Test Method for Analysis of High-Purity *n*-Heptane and Isooctane by Capillary Gas Chromatography
- D2699 Test Method for Research Octane Number of Spark-Ignition Engine Fuel
- D2700 Test Method for Motor Octane Number of Spark-Ignition Engine Fuel
- E1 Specification for ASTM Liquid-in-Glass Thermometers

3. Terminology

3.1 Definitions:

3.1.1 *flash point, n*—the lowest temperature, corrected to a pressure of 760 mm Hg (101.3 kPa, 1013 mbar), at which application of an ignition source causes the vapor of the specimen to ignite by the procedure described.

3.2 Definitions of Terms Specific to This Standard:

3.2.1 *fire point, n*—the lowest temperature at which a specimen sustains burning for a minimum of 5 s by the procedure described.

² For referenced ASTM standards, visit the ASTM website, www.astm.org, or contact ASTM Customer Service at service@astm.org. For *Annual Book of ASTM Standards* volume information, refer to the standard's Document Summary page on the ASTM website.

4. Summary of Method

4.1 The specimen is placed in the cup of a Tag Open-Cup Apparatus and heated at a slow, but constant rate. A small test flame is passed at a uniform rate across the cup at specified intervals until a flash occurs. To determine the fire point, the test is continued until the application of the test flame causes the specimen to ignite and burn for at least 5 s.

5. Significance and Use

5.1 Flash point and fire point of a liquid are physical properties that may be used to define their flammability hazards. The flash point may be used to classify materials in government regulations.

6. Apparatus

6.1 *Flash Tester*—Tag Open-Cup Apparatus (Fig. 1), as described in detail in Annex A1.

6.2 *Shield*, as described in detail in Annex A1.

6.3 *Thermometers*, conforming to Specification E1, as listed in Table 1.

6.4 *Flasks*, 500-mL, two, with rubber stoppers.

7. Materials

7.1 *Water-Glycol Solution* (1 + 1), for flash points from -18 to 93°C (0 to 200°F).

7.2 *Solid Carbon Dioxide-Acetone or other Coolant*.

7.3 *Silicone Fluid*, inert, high boiling, having a flash point exceeding the test temperatures by at least 60°C (110°F) for flash and fire points from 93 to 165°C (200 to 325°F).

7.4 *n-Heptane*,³ for determination of flash points from -18 to 16°C (0 to 60°F). See Annex A2 for specifications.

7.5 *p-Xylene*,³ for determination of flash points from 16 to 93°C (60 to 200°F). See Annex A2 for specifications.

7.6 *Isopropanol (isopropyl alcohol)*,⁴ for determination of flash points from 16 to 93°C (60 to 200°F). See Annex A2 for specifications.

7.7 *Diethylene Glycol*,⁵ for determination of flash points from 93 to 165°C (200 to 325°F). See Annex A2 for specifications.

8. Assembly and Preparation of Apparatus

8.1 Place the tester in a level position on a solid table free of vibration, in a location free of perceptible draft, and in a dim light. Maintain a room temperature of $24 \pm 3^{\circ}\text{C}$ ($75 \pm 5^{\circ}\text{F}$) throughout the test. Other room temperatures may be specified on agreement between buyer and seller.

NOTE 2—For materials with vapors or products of pyrolysis that are objectionable, it is permissible to place the apparatus with shield in a fume hood with the ventilation turned off. The ventilation can then be turned on at completion of the test, or when and if fumes become objectionable.

8.2 Adjust the horizontal and vertical positions of the taper so that the jet passes on the circumference of a circle having a radius of at least 6 in. (150 mm). The jet should pass across the center of the cup at right angles to a diameter passing through the thermometer and in a plane $\frac{1}{8}$ in. (3.2 mm) above the upper edge of the cup as measured from the center of the orifice.

8.3 Using the leveling device as a gage, adjust the height of the taper so that the center of the orifice is exactly $\frac{1}{8}$ in. (3.2 mm) above the top edge of the glass cup when it is in place. It is imperative that this adjustment be made as accurately as possible. Raising or lowering the taper can be achieved by bending it slightly or preferably by adding and removing thin metal shims as required from between the taper and the vertical supporting member of the swivel holder.

8.4 With the glass cup in place in the bath, adjust the thermometer holder so that the thermometer is supported firmly in a vertical position halfway between the center and edge of the cup and on a line passing through the center of the cup and the pivot of the taper. Place the thermometer so that the bottom of the bulb is $\frac{1}{4}$ in. (6.4 mm) from the inner bottom of the cup.

8.5 Set the draft shield around the tester so that the sides form right angles with each other and the tester is well toward the back of the shield.

9. Procedure

9.1 *Flash Points from -18 to 16°C (0 to 60°F) (Warning—* Meticulous attention to all details relating to the taper, size of taper flame, rate of temperature increase, and rate of passing the taper over the sample is necessary for good results.)

9.1.1 Equip two 500-mL flasks with rubber stoppers through which are inserted ASTM 33C (33F) thermometers. Cool a quantity of 1 + 1 water-glycol solution in one stoppered 500-mL flask to approximately -30°C (-20°F) by immersing the flask in a solid carbon dioxide-acetone bath or other coolant. Use extreme care not to contaminate the water-glycol solution with either acetone or carbon dioxide.

9.1.2 Pour the cooled water-glycol solution into the tester bath to a predetermined level 3.2 mm ($\frac{1}{8}$ in.) below the top when the cup is in place. An overflow is desirable for controlling the liquid level in the bath.

9.1.3 At the same time the water-glycol coolant is being chilled, cool a portion of the sample to approximately -25°C (-10°F) in the second stoppered 500-mL flask. If solid carbon dioxide and acetone or other volatile solvents are used as a coolant, extreme care must be exercised to avoid contamination of the sample. Cool the glass cup and place it in the bath. Position the appropriate thermometer (Table 1) as described in 8.4 and fill the cup with cooled sample to a depth approximately 3.2 mm ($\frac{1}{8}$ in.) below the edge as determined by the leveling device.

NOTE 3—Remove all bubbles from the surface of the liquid before starting a determination.

³ Satisfactory *n*-heptane and *p*-xylene can be obtained from Special Products Division, Chemical Department, Phillips Petroleum Company, Drawer O, Borger, TX 79607.

⁴ Satisfactory isopropanol may be obtained from Exxon Chemical, Americus P. O. Box 3272, Houston, TX 77001, Shell Chemical Co., One Shell Plaza, Houston, TX 77002, or Union Carbide Co., P. O. Box 8361, South Charleston, WV 25303.

⁵ Satisfactory diethylene glycol may be obtained from Union Carbide Co., S. Charleston, WV.

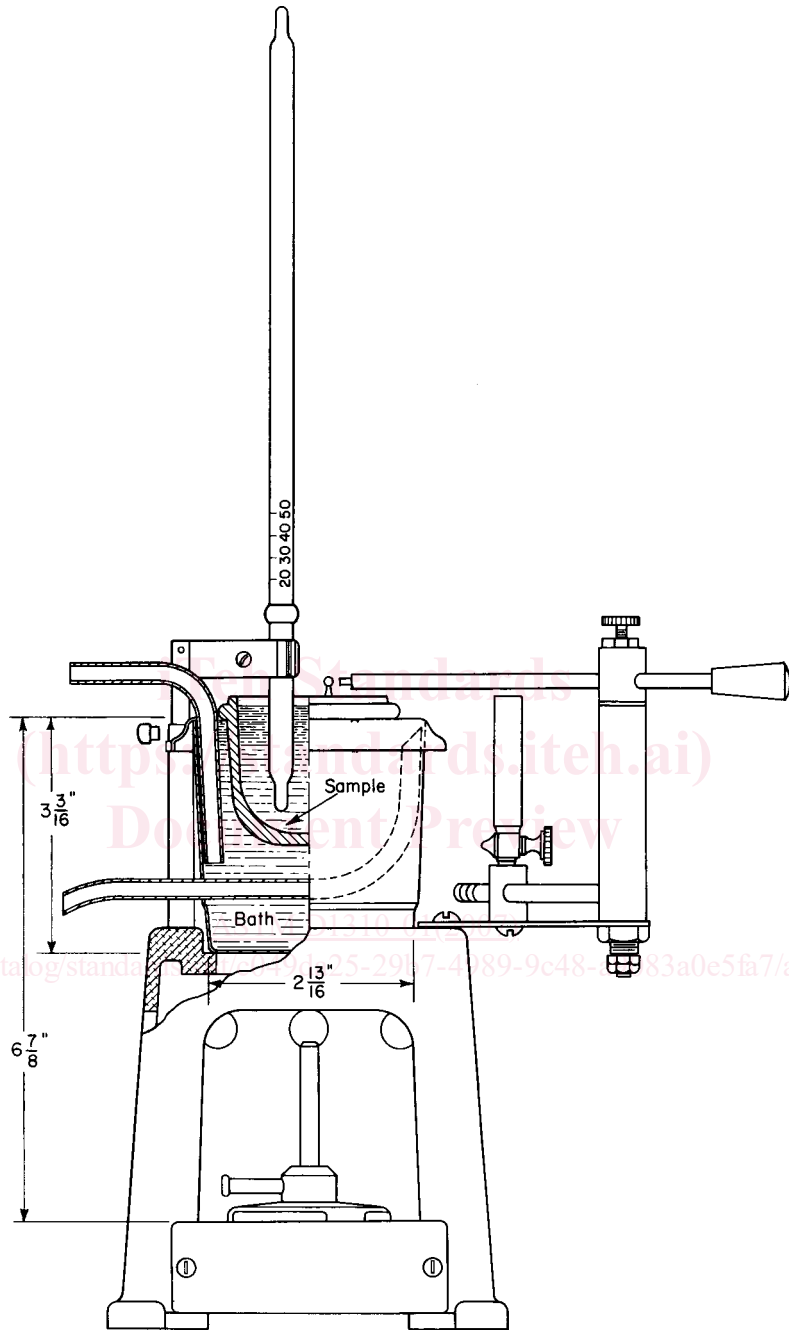

Metric Equivalents

in.	mm
$2\frac{13}{16}$	71.4
$3\frac{3}{16}$	81
$6\frac{7}{8}$	174.5

FIG. 1 Tag Open-Cup Apparatus

TABLE 1 Thermometers

	ASTM Thermometer Number	Thermometer Range	Thermometer Subdivisions
<i>Flash Point/ Fire Point:</i>			
0 to 60°F	33F-75	-36.5 to + 107.5°F	0.5°F
-18 to 15°C	33C-75	-38 to + 42°C	0.2°C
60 to 200°F	9F-75	20 to 230°F	1°F
15 to 93°C	9C-75	-5 to 110°C	0.5°C
200 to 325°F	35F-79	194 to 338°F	0.5°F
93 to 165°C	35C-79	90 to 170°C	0.2°C

9.1.4 Light the ignition flame and adjust it to form a flame of spherical shape matching in size the $\frac{5}{32}$ -in. (4.0-mm) sphere on the apparatus or the $\frac{5}{32}$ -in. hole in the leveling device.

9.1.5 Make the final adjustment of the specimen level in the cup when the temperature is 20°F (10°C) below the anticipated flash point. Two trial determinations may be necessary to select the proper temperature at which to adjust the liquid level. A hypodermic syringe or medicine dropper provides a convenient means of adding or removing sample from the cup.

9.1.6 Allow the temperature of the specimen to increase spontaneously—without applying any heat—until the rate of temperature rise decreases to 2°F (1°C)/min. At this point, apply heat to maintain an increase in temperature at a rate of $2 \pm 0.5^\circ\text{F}$ ($1 \pm 0.25^\circ\text{C}$)/min.

NOTE 4—With viscous materials, this rate of heating cannot always be maintained.

9.1.7 Determine the approximate flash point by passing the taper flame across the specimen at intervals of 2°F (1°C). Make the first pass of the taper flame immediately after the final adjustment of the specimen level, as in 9.1.5. The time required to pass the ignition flame across the surface of the liquid should be 1 s. Each pass must be in one direction only, and the taper should be kept in the “off” position at one or the other end of the swing except when the flame is applied to the specimen. In case the material tends to “creep” over the edge of the cup, carefully wipe the edge with absorbant tissue to remove frost and liquid, just prior to passage of the taper over the cup.

NOTE 5—When determining the flash point or fire point, or both, of viscous liquids and those liquids that tend to form a surface film, the following procedure is suggested: About 15 s before the taper is passed over the surface, insert the end of a stirring rod to a depth of about $\frac{1}{2}$ in. (15 mm) in approximately a vertical position. Move the rod from side-to-side of the cup for three or four complete passes following approximately the path of the taper, remove, and make the test.

NOTE 6—Discontinue heating and checking flash point if the specimen boils before flashing. Record that the material has no flash point prior to boiling.

9.1.8 Continue with procedure in 9.4.

9.2 *Flash Points from 60 to 200°F* (16 to 93°C) (See 9.1 and Notes 3-5):

9.2.1 Fill the bath with cold water or water-glycol solution to a predetermined level $\frac{1}{8}$ in. (3.2 mm) below the top when the cup is in place. The bath liquid should be at least 30°F (17°C) below the anticipated flash point.

9.2.2 If necessary, cool a portion of the sample to at least 20°F (10°C) below the anticipated flash point. Exercise adequate care to avoid contamination of the sample with coolant

liquid or vapors. Fill the glass cup with the cooled sample to a depth approximately $\frac{1}{8}$ in. (3.2 mm) below the edge as determined by the leveling device, with the proper thermometer (see Table 1) positioned as described in 8.4.

9.2.3 For final adjustment of the specimen level, see 9.1.5.

9.2.4 Light the ignition flame and adjust it as described in 9.1.4.

9.2.5 Apply heat to the liquid bath and adjust so that the temperature of the specimen increases at a rate of $2 \pm 0.5^\circ\text{F}$ ($1 \pm 0.25^\circ\text{C}$)/min.

9.2.6 Determine the approximate flash point by passing the taper flame across the specimen at intervals of 2°F (1°C) as described in 9.1.7.

9.2.7 Continue with procedure in 9.4.

9.3 *Procedure for Flash Points from 200 to 325°F* (93 to 165°C) (See 9.1 and Notes 3-5):

9.3.1 Fill the bath with a high-boiling inert silicone fluid to a predetermined level $\frac{1}{8}$ in. (3.2 mm) below the top when the cup is in place.

9.3.2 With the appropriate thermometer (see Table 1) properly positioned (8.4), fill the glass cup with sample at room temperature to a depth slightly more than $\frac{1}{8}$ in. (3.2 mm) below the edge as determined by the leveling device.

9.3.3 For final adjustment of the specimen level, see 9.1.5.

9.3.4 Light the ignition flame and adjust it as described in 9.1.4.

9.3.5 Apply full heat to the liquid bath; when the temperature of the specimen reaches approximately 190°F (90°C), adjust the heat input so that the temperature of the specimen increases at a rate of $2 \pm 0.5^\circ\text{F}$ ($1 \pm 0.25^\circ\text{C}$)/min.

NOTE 7—The heaters on some testers do not have sufficient capacity to maintain the proper rate of heating when the temperature approaches 250°F (120°C) or above. The heat input to the liquid bath may be increased if necessary by using a variable transformer to increase the voltage to the heater or by wrapping the bath with electrical heating tape. The application of suitable insulation to the outside of the bath to prevent heat loss is also permissible. The important factor is to maintain the rate of temperature increase of the specimen at $2 \pm 0.5^\circ\text{F}$ ($1 \pm 0.25^\circ\text{C}$)/min.

9.3.6 Determine the approximate flash point by passing the taper flame across the specimen at intervals of 2°F (1°C) as described in 9.1.7.

9.4 Determine and record not less than three test values, as follows:

9.4.1 After the initial test to determine the approximate flash point of the materials, repeat the procedure by cooling a fresh portion of the sample, the glass cup, the bath solution, and the thermometer to more than 20°F (10°C) below the approximate flash point. When the temperature of the specimen is exactly 20°F below the approximate flash point, adjust the center of the liquid level to $\frac{1}{8}$ in. (3.2 mm) below the upper edge of the cup as determined with the leveling device placed across the diameter of the cup.

9.4.2 Resume heating, or allow the temperature to rise spontaneously in the case of materials flashing below 60°F (16°C). Following the instructions given in 9.1.7, pass the taper flame across the specimen at two intervals of 5°F (3°C) and then at intervals of 2°F (1°C) until the flash point is reached.

9.5 *Fire Point (Sustained Burning):*