



Designation: D4938 – 89 (Reapproved2007)

# Standard Test Method for Erosion Testing of Antifouling Paints Using High Velocity Water<sup>1</sup>

This standard is issued under the fixed designation D4938; the number immediately following the designation indicates the year of original adoption or, in the case of revision, the year of last revision. A number in parentheses indicates the year of last reapproval. A superscript epsilon ( $\epsilon$ ) indicates an editorial change since the last revision or reapproval.

## 1. Scope

1.1 This test method covers the determination of erosion rates for marine antifouling paint systems immersed in flowing natural seawater.

1.2 *This standard does not purport to address all of the safety concerns, if any, associated with its use. It is the responsibility of the user of this standard to establish appropriate safety and health practices and determine the applicability of regulatory limitations prior to use.* For a specific hazard statement, see Section 7.

## 2. Referenced Documents

2.1 *ASTM Standards:*<sup>2</sup>

[A569/A569M Specification for Steel, Carbon \(0.15 Maximum, Percent\), Hot-Rolled Sheet and Strip Commercial \(Withdrawn 2000\)](#)<sup>3</sup>

[D823 Practices for Producing Films of Uniform Thickness of Paint, Varnish, and Related Products on Test Panels](#)

[D1889 Test Method for Turbidity of Water \(Withdrawn 2007\)](#)<sup>3</sup>

[D2200 Practice for Use of Pictorial Surface Preparation Standards and Guides for Painting Steel Surfaces](#)

2.2 *U.S. Military Specifications:*<sup>4</sup>

[MIL-P-24441 Paint, Epoxy-Polyamide](#)

[DOD-P-24647 Paint, Antifouling, Ship Hull \(Metric\)](#)

[DOD-P-24655 Paint, Underwater Hull, Anticorrosion \(Metric\)](#)

<sup>1</sup> This test method is under the jurisdiction of ASTM Committee D01 on Paint and Related Coatings, Materials, and Applications and is the direct responsibility of Subcommittee D01.45 on Marine Coatings.

Current edition approved June 1, 2007. Published August 2007. Originally approved in 1989. Last previous edition approved in 2002 as D4938 - 89 (2002). DOI: 10.1520/D4938-89R07.

<sup>2</sup> For referenced ASTM standards, visit the ASTM website, [www.astm.org](http://www.astm.org), or contact ASTM Customer Service at [service@astm.org](mailto:service@astm.org). For *Annual Book of ASTM Standards* volume information, refer to the standard's Document Summary page on the ASTM website.

<sup>3</sup> The last approved version of this historical standard is referenced on [www.astm.org](http://www.astm.org).

<sup>4</sup> Available from Standardization Documents Order Desk, DODSSP, Bldg. 4, Section D, 700 Robbins Ave., Philadelphia, PA 19111-5098, <http://www.dodssp.daps.mil>.

## 3. Summary of Test Method

3.1 Steel panels coated with the antifouling paint system under evaluation are positioned in a high velocity water channel, similar to the type shown in [Figs. 1-3](#), parallel to the path of the flowing water.

3.2 Exposure conditions shall include at least one series of test panels evaluated at the standard water velocity of 12 m/s and shall specify the length of time, temperature, salinity, and pH. Additional velocities may be conducted at the discretion of the customer.

3.3 Color photographs and coating thickness measurements shall be taken prior to exposure, at specified time intervals, and repeated at the end of the test for comparison purposes.

## 4. Significance and Use

4.1 This test method is intended to measure the erosion rates of ablative antifouling paint systems exposed to flowing water at velocities designed to subject the paint system to shear stresses experienced in service.

4.2 Measurement of erosion rates are necessary to help in the assessment of ablative antifouling paint film thicknesses required for fouling control between scheduled drydockings of ships, in the selection of materials, in producing quality assurance, and in understanding the performance mechanism.

4.3 The test data is intended to serve as a guide for predicting the service life of ablative antifouling paints in order to calculate the necessary paint thickness to fit specified deployment cycles. Erosion rates of antifouling paints in service will vary depending on such factors as: berthing location, geographic area of operation, salinity, pH, and temperature of seawater. It should also be recognized that some areas of the ship are subject to different erosion rates.

4.4 The degree of correlation between results obtained from this test method and shipboard service has not been determined.

## 5. Apparatus

### 5.1 Water Channel:

5.1.1 High velocity flowing water in a contained channel, similar to the type shown in [Figs. 1-3](#), is used to induce

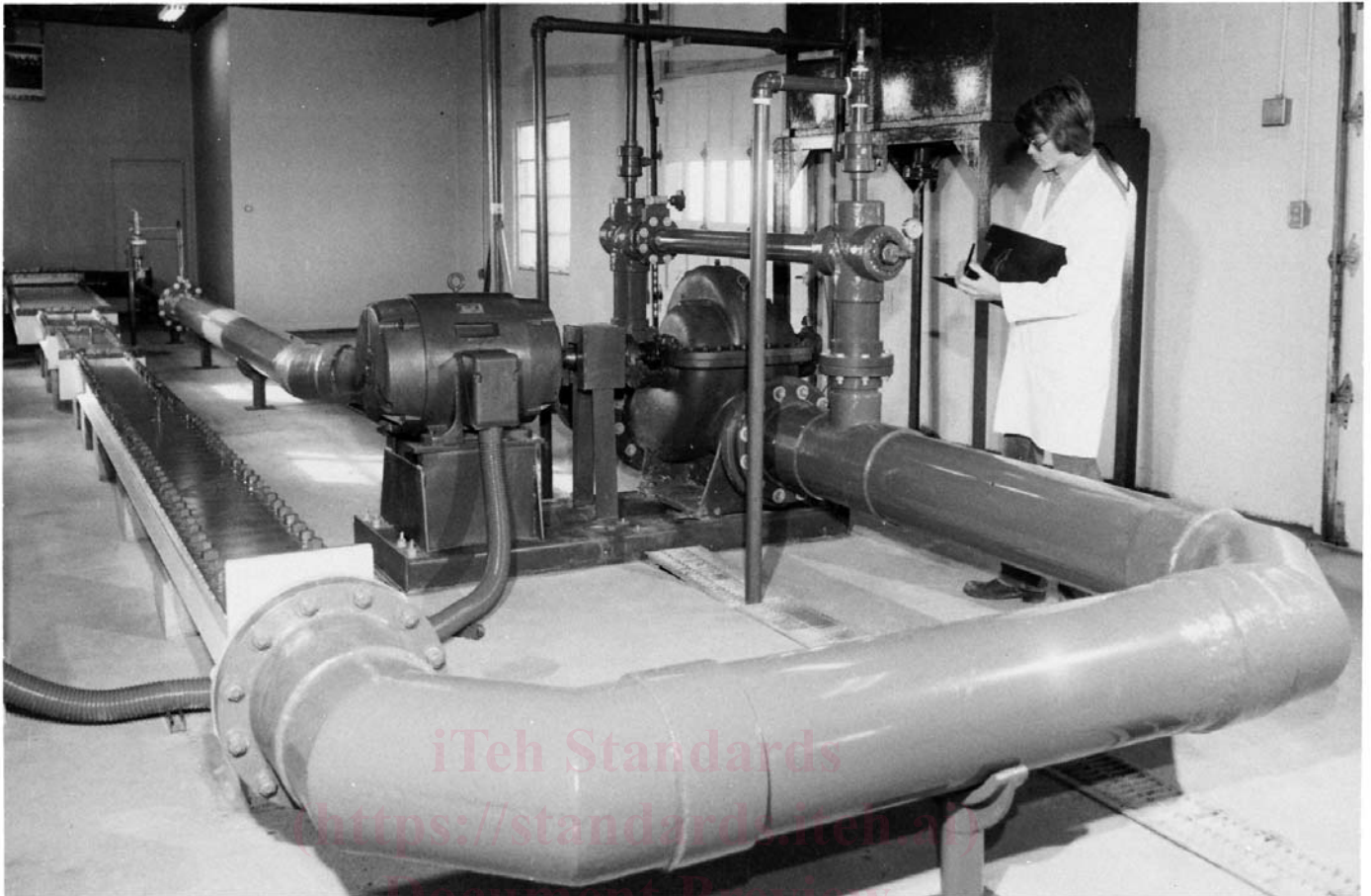

FIG. 1 High Velocity Flow Channel

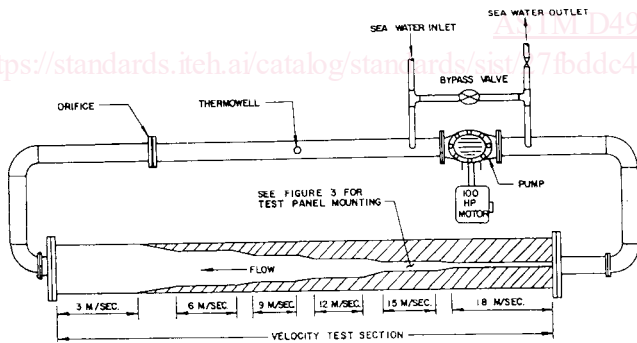
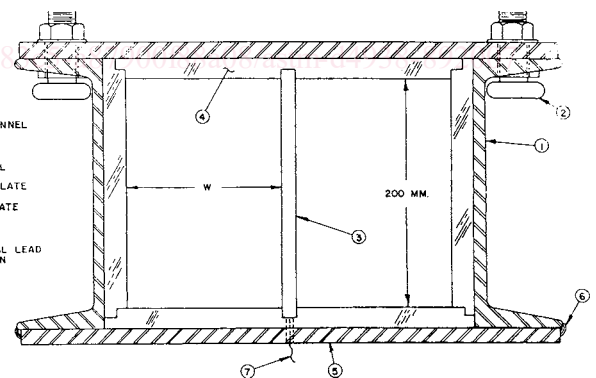

FIG. 2 Simplified Schematic of Flow Channel



W, mm	Velocity, m/s
50	18
60	15
75	12
100	9
150	6
300	3

FIG. 3 Cross-Section View of Test Panel Mounted in Flow Channel (Low Velocity Section)

hydrodynamic shear stresses on painted panels to determine erosion rates of ablative antifouling paints.

5.1.2 The basic apparatus consists of a four-walled channel, rectangular in cross section, through which natural seawater flows at varying linear velocities to simulate ships' speeds.

5.1.3 All wetted materials supplying seawater to and within the channel shall be nonmetallic with the following exceptions:

5.1.3.1 Channel circulating pump impellers.

5.1.3.2 Thermowells.

5.1.3.3 Channel flow orifice plate.

5.1.4 One section of the channel shall permit testing of the panels at a standard test velocity of 12 m/s. All sections of the

channel shall provide flow with fully formed turbulent characteristics. A minimum Reynolds number of 1 000 000 shall be achieved in each velocity test section. The Reynolds number,  $R$ , is calculated as follows: