

---

---

**Rubber, vulcanized or thermoplastic —  
Determination of permeability to gases —**

**Part 2:  
Equal-pressure method**

*Caoutchouc vulcanisé ou thermoplastique — Détermination de la  
perméabilité aux gaz —*

*Partie 2: Méthode équi-pression*

iTeh STANDARD PREVIEW  
(standards.iteh.ai)

ISO 2782-2:2012

<https://standards.iteh.ai/catalog/standards/sist/3fd7e4fd-b743-4491-a01f-4bea89cb11ad/iso-2782-2-2012>



## iTeh STANDARD PREVIEW (standards.iteh.ai)

ISO 2782-2:2012

<https://standards.iteh.ai/catalog/standards/sist/3fd7e4fd-b743-4491-a01f-4bea89cb11ad/iso-2782-2-2012>



### **COPYRIGHT PROTECTED DOCUMENT**

© ISO 2012

All rights reserved. Unless otherwise specified, no part of this publication may be reproduced or utilized in any form or by any means, electronic or mechanical, including photocopying and microfilm, without permission in writing from either ISO at the address below or ISO's member body in the country of the requester.

ISO copyright office  
Case postale 56 • CH-1211 Geneva 20  
Tel. + 41 22 749 01 11  
Fax + 41 22 749 09 47  
E-mail [copyright@iso.org](mailto:copyright@iso.org)  
Web [www.iso.org](http://www.iso.org)

Published in Switzerland

<b>Contents</b>	<b>Page</b>
Foreword .....	iv
Introduction .....	v
1 Scope .....	1
2 Normative references .....	1
3 Terms and definitions .....	1
4 Principle .....	1
5 Apparatus .....	2
6 Calibration .....	3
7 Test gas .....	3
8 Carrier gas .....	3
9 Test pieces .....	3
9.1 Shape and dimensions .....	3
9.2 Preparation .....	3
9.3 Number of test pieces .....	3
9.4 Measurement of thickness .....	3
9.5 Time interval between forming and testing .....	3
10 Conditioning .....	3
11 Test conditions .....	3
12 Gas transmission area .....	4
13 Calibration curve .....	4
14 Procedure .....	4
15 Calculation and expression of results .....	5
15.1 Gas transmission rate .....	5
15.2 Gas permeability coefficient .....	5
16 Test report .....	5
Annex A (normative) Calibration schedule .....	7

## Foreword

ISO (the International Organization for Standardization) is a worldwide federation of national standards bodies (ISO member bodies). The work of preparing International Standards is normally carried out through ISO technical committees. Each member body interested in a subject for which a technical committee has been established has the right to be represented on that committee. International organizations, governmental and non-governmental, in liaison with ISO, also take part in the work. ISO collaborates closely with the International Electrotechnical Commission (IEC) on all matters of electrotechnical standardization.

International Standards are drafted in accordance with the rules given in the ISO/IEC Directives, Part 2.

The main task of technical committees is to prepare International Standards. Draft International Standards adopted by the technical committees are circulated to the member bodies for voting. Publication as an International Standard requires approval by at least 75 % of the member bodies casting a vote.

Attention is drawn to the possibility that some of the elements of this document may be the subject of patent rights. ISO shall not be held responsible for identifying any or all such patent rights.

ISO 2782-2 was prepared by Technical Committee ISO/TC 45, *Rubber and rubber products*, Subcommittee SC 2, *Testing and analysis*.

Together with Part 1, it cancels and replaces ISO 2782:2006, which has been technically revised.

ISO 2782 consists of the following parts, under the general title *Rubber, vulcanized or thermoplastic — Determination of permeability to gases*:

- Part 1: *Differential-pressure methods*
- Part 2: *Equal-pressure method*

**iTeh STANDARD PREVIEW**  
**(standards.iteh.ai)**

<https://standards.iteh.ai/catalog/standards/sist/3fd7e4fd-b743-4491-a01f-4bea89cb11ad/iso-2782-2-2012>

## Introduction

The measurement of the permeability of rubber to gases is important in the evaluation of compounds for products such as inner tubes, tubeless-tyre liners, hoses, balloons and other gas-containing products, as well as seals and diaphragms. The measurement is also of theoretical importance in the study of the characteristics of gas diffusion and gas solubility in relation to polymer structure.

## iTeh STANDARD PREVIEW (standards.iteh.ai)

[ISO 2782-2:2012](https://standards.iteh.ai/catalog/standards/sist/3fd7e4fd-b743-4491-a01f-4bea89cb11ad/iso-2782-2-2012)

<https://standards.iteh.ai/catalog/standards/sist/3fd7e4fd-b743-4491-a01f-4bea89cb11ad/iso-2782-2-2012>

**iTeh STANDARD PREVIEW**  
**(standards.iteh.ai)**

ISO 2782-2:2012

<https://standards.iteh.ai/catalog/standards/sist/3fd7e4fd-b743-4491-a01f-4bea89cb11ad/iso-2782-2-2012>

# Rubber, vulcanized or thermoplastic — Determination of permeability to gases —

## Part 2: Equal-pressure method

**WARNING** — Persons using this part of ISO 2782 should be familiar with normal laboratory practice. This part of ISO 2782 does not purport to address all of the safety problems, if any, associated with its use. It is the responsibility of the user to establish appropriate safety and health practices and to ensure compliance with any national regulatory conditions.

### 1 Scope

This part of ISO 2782 specifies a method for the determination of the gas transmission rate and gas permeability coefficient of vulcanized or thermoplastic rubber under conditions in which the overall pressure on each side of the rubber test piece is the same, using gas chromatography to determine the quantity of gas that permeates through the rubber.

The method applies to vulcanized and thermoplastic rubbers of hardness not less than 35 IRHD (international rubber hardness degrees) and to both single gases and mixtures of gases.

### 2 Normative references

The following referenced documents are indispensable for the application of this document. For dated references, only the edition cited applies. For undated references, the latest edition of the referenced document (including any amendments) applies.

ISO 2782-1:2012, *Rubber, vulcanized or thermoplastic — Determination of permeability to gases — Part 1: Differential-pressure methods*

ISO 18899:2004, *Rubber — Guide to the calibration of test equipment*

ISO 23529, *Rubber — General procedures for preparing and conditioning test pieces for physical test methods*

### 3 Terms and definitions

For the purposes of this document, the terms and definitions given in ISO 2782-1 apply.

### 4 Principle

A test cell, maintained at constant temperature, is divided by a test piece into a gas supply side and a gas transmission side (see Figure 1). The test gas is supplied to the gas supply side and a carrier gas is passed through the gas transmission side. The pressure on both sides of the cell is equal (atmospheric pressure) but, since the partial pressure of the test gas is higher on the gas supply side, it diffuses through the test piece into the gas transmission side. The quantity of test gas passing through the test piece is measured using a gas chromatograph.

In this method, measurements are possible on test gases containing water vapour, and it is also possible to analyse mixtures of gases to determine the components.

## 5 Apparatus

The apparatus consists of the test cell, a gas chromatograph, test gas and carrier gas supply systems and associated tubing and valves. An example of a test apparatus is shown in Figure 1.

**5.1 Test cell**, consisting of a gas supply side and a gas transmission side, such that, when a test piece is mounted in it, the gas transmission area is clearly defined. The gas supply side has a test gas inlet port and an exhaust port and the gas transmission side is connected to the carrier gas supply and, through a sampling loop, to the gas chromatograph. The material of the test cell shall be unreactive with regard to the test gas and shall not absorb the gas used. The surfaces of the two halves of the cell which make contact with the test piece shall be smooth and flat to prevent any leakage of gas. A seal such as an O-ring may be used between these areas and the test piece, in which case the gas transmission rate of the seal shall be considerably lower than that of the material being tested so that it does not affect the result of the test. The diameter of the gas transmission area shall be within the range 10 mm to 150 mm, depending on the gas transmission rate expected.

The cell shall be equipped with a heating system capable of raising the temperature to 80 °C. The temperature accuracy shall be  $\pm 1$  °C for temperatures from 40 °C to 80 °C.

NOTE Examples of a heating system are an electric heating jacket and an oven designed to hold the test cell and test gas supply.

**5.2 Gas chromatograph**, having a detector such as a thermal conductivity detector (TCD) or a hydrogen flame ionization detector (FID). The detector and column shall be suitable for the test gas used and of the required sensitivity.

**5.3 Test gas controller**, in accordance with 6.1.4 of ISO 2782-1:2012.

**5.4 Two temperature sensors**, the first fitted in the test cell for measuring the test temperature and the second fitted in the flow of carrier gas to measure the temperature of the carrier gas. The sensors shall be capable of reading to within 0.1 °C or better.

**iTeh STANDARD PREVIEW**  
(standards.iteh.ai)

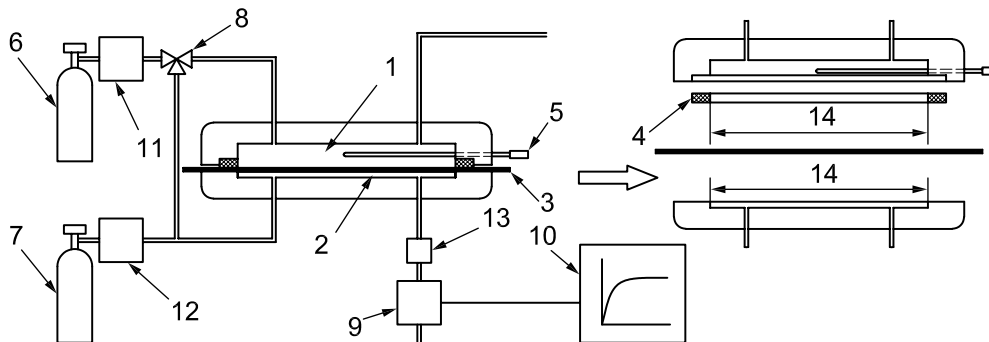

**Key**

- |                         |                         |                                   |
|-------------------------|-------------------------|-----------------------------------|
| 1 gas supply side       | 6 test gas supply       | 11 test gas controller            |
| 2 gas transmission side | 7 carrier gas supply    | 12 carrier gas controller         |
| 3 test piece            | 8 three-way valve       | 13 sampling loop with thermometer |
| 4 sealing ring          | 9 gas chromatograph     | 14 gas transmission area          |
| 5 temperature sensor    | 10 data-processing unit |                                   |

**Figure 1 — Example of gas permeability measuring apparatus**  
(diagram at right shows an exploded view of the test cell)



## 6 Calibration

The test apparatus shall be calibrated in accordance with the schedule given in Annex A

## 7 Test gas

Use a single gas, such as nitrogen, oxygen or hydrogen, or a mixture of gases, such as air, liquefied petroleum gas (in gaseous form) or coal gas. The purity of a single gas or the purity of each component in a gas mixture shall be 99,5 % by volume or higher, unless otherwise agreed between the interested parties, in which case a gas of lower purity may be used. The test gas shall not include any impurity that might affect the measurement.

When using a gas mixture, the purity of each component shall be verified in advance with a suitable instrument, such as a gas chromatograph.

When using a toxic and/or flammable gas, all necessary precautions should be taken in its use and in its recovery or disposal.

## 8 Carrier gas

See 6.4 of ISO 2782-1:2012.

## 9 Test pieces

### 9.1 Shape and dimensions

See 5.4.1 of ISO 2782-1:2012.

### 9.2 Preparation

See 5.4.2 of ISO 2782-1:2012.

iTech STANDARD PREVIEW  
(standards.iteh.ai)  
<https://standards.iteh.ai/catalog/standards/sist/3fd7e4fd-b743-4491-a01f-4bea89cb11ad/iso-2782-2-2012>

### 9.3 Number of test pieces

See 5.4.3 of ISO 2782-1:2012.

### 9.4 Measurement of thickness

See 5.4.4 of ISO 2782-1:2012.

### 9.5 Time interval between forming and testing

See 5.4.5 of ISO 2782-1:2012.

## 10 Conditioning

See 5.5 of ISO 2782-1:2012.

## 11 Test conditions

See 5.6 of ISO 2782-1:2012.

For the test gas and carrier gas, the standard pressure is atmospheric pressure.