

INTERNATIONAL STANDARD

AMENDMENT 2

Information technology – Generic cabling for customer premises

(standards.iteh.ai)

[ISO/IEC 11801:2002/Amd 2:2010](https://standards.iteh.ai/catalog/standards/sist/04448a83-47f4-4525-9034-5c8d0586ef0d/iso-iec-11801-2002-amd-2-2010)

<https://standards.iteh.ai/catalog/standards/sist/04448a83-47f4-4525-9034-5c8d0586ef0d/iso-iec-11801-2002-amd-2-2010>



THIS PUBLICATION IS COPYRIGHT PROTECTED
Copyright © 2010 ISO/IEC, Geneva, Switzerland

All rights reserved. Unless otherwise specified, no part of this publication may be reproduced or utilized in any form or by any means, electronic or mechanical, including photocopying and microfilm, without permission in writing from either IEC or IEC's member National Committee in the country of the requester.

If you have any questions about ISO/IEC copyright or have an enquiry about obtaining additional rights to this publication, please contact the address below or your local IEC member National Committee for further information.

IEC Central Office
3, rue de Varembe
CH-1211 Geneva 20
Switzerland
Email: inmail@iec.ch
Web: www.iec.ch

About the IEC

The International Electrotechnical Commission (IEC) is the leading global organization that prepares and publishes International Standards for all electrical, electronic and related technologies.

About IEC publications

The technical content of IEC publications is kept under constant review by the IEC. Please make sure that you have the latest edition, a corrigenda or an amendment might have been published.

- Catalogue of IEC publications: www.iec.ch/searchpub

The IEC on-line Catalogue enables you to search by a variety of criteria (reference number, text, technical committee,...). It also gives information on projects, withdrawn and replaced publications.

- IEC Just Published: www.iec.ch/online_news/justpub

Stay up to date on all new IEC publications. Just Published details twice a month all new publications released. Available on-line and also by email.

- Electropedia: www.electropedia.org

The world's leading online dictionary of electronic and electrical terms containing more than 20 000 terms and definitions in English and French, with equivalent terms in additional languages. Also known as the International Electrotechnical Vocabulary online.

- Customer Service Centre www.iec.ch/webstore/custserv

If you wish to give us your feedback on this publication or need further assistance, please visit the Customer Service Centre FAQ or contact us:

Email: csc@iec.ch
Tel.: +41 22 919 02 11
Fax: +41 22 919 03 00



ISO/IEC 11801

Edition 2.0 2010-04

INTERNATIONAL STANDARD

AMENDMENT 2

Information technology – Generic cabling for customer premises
(standards.iteh.ai)

ISO/IEC 11801:2002/Amd 2:2010
<https://standards.iteh.ai/catalog/standards/sist/04448a83-47f4-4525-9034-5c8d0586ef0d/iso-iec-11801-2002-amd-2-2010>

INTERNATIONAL
ELECTROTECHNICAL
COMMISSION

PRICE CODE

XA

ICS 35.200

ISBN 978-2-88910-819-0

FOREWORD

Amendment 2 to International Standard ISO/IEC 11801 was prepared by subcommittee 25: Interconnection of information technology, of ISO/IEC joint technical committee 1: Information technology.

This International Standard has been approved by vote of the member bodies, and the voting results may be obtained from the address given on the second title page.

INTRODUCTION

Add, at the end of the existing introductions the following text:

INTRODUCTION to Amendment 2

Amendment 2 of ISO/IEC 11801:2002 provides balanced cabling models, requirements and normative references for Category 6_A and Category 7_A components, requirements for Class E_A and Class F_A links, together with amendments to the requirements for optical fibre cabling.

Global change:

Replace, throughout ISO/IEC 11801:2002 and Amendment 1:2008 “optical fibre channel” by “optical fibre cabling channel”

2 Normative references

Replace the entire existing Clause 2 of both ISO/IEC 11801:2002, as well Amendment 1:2008, by the following:

The following referenced documents are indispensable for the application of this document. For dated references, only the edition cited applies. For undated references, the latest edition of the referenced document (including any amendments) applies.

The provisions of the referenced specifications other than ISO/IEC, IEC, ISO and ITU documents, as identified in this clause, are valid within the context of this International Standard. The reference to such a specification within this International Standard does not give it any further status within ISO or IEC. In particular, it does not give the referenced specification the status of an International Standard.

IEC 60352 (all parts), *Solderless connections*

IEC 60352-3, *Solderless connections – Part 3: Solderless accessible insulation displacement connections – General requirements, test methods and practical guidance*

IEC 60352-4, *Solderless connections – Part 4: Solderless non-accessible insulation displacement connections – General requirements, test methods and practical guidance*

IEC 60352-5, *Solderless connections – Part 5: Press-in connections – General requirements, test methods and practical guidance*

IEC 60352-6, *Solderless connections – Part 6: Insulation piercing connections – General requirements, test methods and practical guidance*

IEC 60352-7, *Solderless connections – Part 7: Spring clamp connections – General requirements, test methods and practical guidance*

IEC 60352-8, *Solderless connections – Part 8: Compression mount connections – General requirements, test methods and practical guidance*¹

IEC 60364-1, *Low-voltage electrical installations – Part 1: Fundamental principles, assessment of general characteristics, definitions*

IEC 60512-2-1, *Connectors for electronic equipment – Tests and measurements – Part 2-1: Electrical continuity and contact resistance tests – Test 2a: Contact resistance – Millivolt level method*

IEC 60512-3-1, *Connectors for electronic equipment – Tests and measurements – Part 3-1: Insulation tests – Test 3a: Insulation resistance*

IEC 60512-4-1, *Connectors for electronic equipment – Tests and measurements – Part 4-1: Voltage stress tests – Test 4a: Voltage proof*

IEC 60512-5-2, *Connectors for electronic equipment – Tests and measurements – Part 5-2: Current-carrying capacity tests – Test 5b: Current-temperature derating*

IEC 60512-25-1, *Connectors for electronic equipment – Tests and measurements – Part 25-1: Test 25a – Crosstalk ratio*

IEC 60512-25-2:2002, *Connectors for electronic equipment – Tests and measurements – Part 25-2: Test 25b – Attenuation (insertion loss)*

IEC 60512-25-4:2001, *Connectors for electronic equipment – Tests and measurements – Part 25-4: Test 25d – Propagation delay*

IEC 60512-25-5, *Connectors for electronic equipment – Tests and measurements – Part 25-5: Test 25e – Return loss*

IEC 60512-25-9:2008, *Connectors for electronic equipment – Tests and measurements – Part 25-9: Signal integrity tests – Test 25i: Alien crosstalk*

IEC 60512-26-100, *Connectors for electronic equipment – Tests and measurements – Part 26-100: Measurement setup, test and reference arrangements and measurements for connectors according to IEC 60603-7 – Tests 26a to 26g*

IEC 60603-7, *Connectors for electronic equipment – Part 7: Detail specification for 8-way, unshielded, free and fixed connectors*

IEC 60603-7-1, *Connectors for electronic equipment – Part 7-1: Detail specification for 8-way, shielded free and fixed connectors*

IEC 60603-7-2:–, *Connectors for electronic equipment – Part 7-2: Detail specification for 8-way, unshielded, free and fixed connectors, for data transmissions with frequencies up to 100 MHz²*

¹ To be published.

² Second edition to be published.

IEC 60603-7-3:–, *Connectors for electronic equipment – Part 7-3: Detail specification for 8-way, shielded, free and fixed connectors, for data transmissions with frequencies up to 100 MHz*³

IEC 60603-7-4:–, *Connectors for electronic equipment – Part 7-4: Detail specification for 8-way, unshielded, free and fixed connectors, for data transmissions with frequencies up to 250 MHz*⁴

IEC 60603-7-5:–, *Connectors for electronic equipment – Part 7-5: Detail specification for 8-way, shielded, free and fixed connectors, for data transmissions with frequencies up to 250 MHz*⁵

IEC 60603-7-7:–, *Connectors for electronic equipment – Part 7-7: Detail specification for 8-way, shielded, free and fixed connectors, for data transmission with frequencies up to 600 MHz*⁶

IEC 60603-7-41:–, *Connectors for electronic equipment – Part 7-41: Detail specification for 8-way, unshielded, free and fixed connectors, for data transmissions with frequencies up to 500 MHz*

IEC 60603-7-51:–, *Connectors for electronic equipment – Part 7-51: Detail specification for 8-way, shielded, free and fixed connectors, for data transmissions with frequencies up to 500 MHz*

IEC 60603-7-71:–, *Connectors for electronic equipment – Part 7-71: Detail specification for 8-way, shielded, free and fixed connectors, for data transmission with frequencies up to 1 000 MHz*⁷

IEC 60793-1-40, *Optical fibres – Part 1-40: Measurement methods and test procedures – Attenuation*

IEC 60793-1-44, *Optical fibres – Part 1-44: Measurement methods and test procedures – Cut-off wavelength*

IEC 60793-1-49, *Optical fibres – Part 1-49: Measurement methods and test procedures – Differential mode delay*

IEC 60793-2:2007, *Optical fibres – Part 2: Product specifications – General*

IEC 60793-2-10, *Optical fibres – Part 2-10: Product specifications – Sectional specification for category A1 multimode fibres*

IEC 60793-2-50, *Optical fibres – Part 2-50: Product specifications – Sectional specification for class B single-mode fibres*

IEC 60794 (all parts), *Optical fibre cables*

IEC 60794-2, *Optical fibre cables – Part 2: Indoor cables – Sectional specification*

³ Second edition to be published.

⁴ Second edition to be published.

⁵ Second edition to be published.

⁶ Third edition to be published.

⁷ To be published.

IEC 60825 (all parts), *Safety of laser products*

IEC 60874-19-1:2007, *Fibre optic interconnecting devices and passive components Connectors for optical fibres and cables – Part 19-1: Fibre optic patch cord connector type SC-PC (floating duplex) standard terminated on multimode fibre type A1a, A1b – Detail specification*

IEC 60874-19-2:1999, *Connectors for optical fibres and cables – Part 19-2: Fibre optic adaptor (duplex) type SC for single-mode fibre connectors – Detail specification*

IEC 60874-19-3:2007, *Fibre optic interconnecting devices and passive components – Connectors for optical fibres and cables – Part 19-3 Fibre optic adaptor (duplex) type SC for multimode fibre connectors – Detail specification*

IEC 61073-1, *Fibre optic interconnecting devices and passive components – Mechanical splices and fusion splice protectors for optical fibres and cables – Part 1: Generic specification*

IEC 61076-3-104, *Connectors for electronic equipment – Part 3-104: Detail specification for 8-way, shielded free and fixed connectors for data transmissions with frequencies up to 1 000 MHz*

IEC 61076-3-110, *Connectors for electronic equipment – Part 3-110: Detail specification for shielded, free and fixed connectors for data transmission with frequencies up to 1 000 MHz*

IEC 61156 (all parts), *Multicore and symmetrical pair/quad cables for digital communications*
(standards.iteh.ai)

IEC 61156-1:2007, *Multicore and symmetrical pair/quad cables for digital communications – Part 1: Generic specification* [ISO/IEC 11801:2002/Amd 2:2010](https://standards.iteh.ai/catalog/standards/sist/04448a83-47f4-4525-9034-5c8d0586ef0d/iso-iec-11801-2002-amd-2-2010)

Amendment 1 (2009) <https://standards.iteh.ai/catalog/standards/sist/04448a83-47f4-4525-9034-5c8d0586ef0d/iso-iec-11801-2002-amd-2-2010>

IEC 61156-2:, *Multicore and symmetrical pair/quad cables for digital communications – Part 2: Symmetrical pair/quad cables with transmission characteristics up to 100 MHz – Horizontal floor cable – Sectional specification*

IEC 61156-3:2008, *Multicore and symmetrical pair/quad cables for digital communications – Part 3: Work area wiring – Sectional specification*

IEC 61156-4:2009, *Multicore and symmetrical pair/quad cables for digital communications – Part 4: Riser cables – Sectional specification*

IEC 61156-5:2009, *Multicore and symmetrical pair/quad cables for digital communications – Part 5: Symmetrical pair/quad cables with transmission characteristics up to 1 000 MHz – Horizontal floor wiring – Sectional specification*

IEC 61156-6, *Multicore and symmetrical pair/quad cables for digital communications – Part 6: Symmetrical pair/quad cables with transmission characteristics up to 1 000 MHz – Work area wiring – Sectional specification⁸*

IEC 61300-1, *Fibre optic interconnecting devices and passive components – Basic test and measurement procedures – Part 1: General and guidance*

IEC 61300-2-2:1995, *Fibre optic interconnecting devices and passive components – Basic test and measurement procedures – Part 2-2: Tests – Mating durability*

⁸ Refers to the third edition which is currently in preparation

IEC 61300-3-6:1997, *Fibre optic interconnecting devices and passive components – Basic test and measurement procedures – Part 3-6: Examinations and measurements – Return loss*
Amendment 1:1998
Amendment 2:1999

IEC 61300-3-34:2001, *Fibre optic interconnecting devices and passive components – Basic test and measurement procedures – Part 3-34: Examinations and measurements – Attenuation of random mated connectors*

IEC 61754-20:2002, *Fibre optic connector interfaces – Part 20: Type LC connector family*

IEC 61935-1, *Specification for the testing of balanced communication cabling in accordance with ISO/IEC 11801 – Part 1: Installed cabling*

IEC 61935-2, *Testing of balanced communication cabling in accordance with ISO/IEC 11801 – Part 2: Patch cords and work area cords*

IEC 62153-4-12, *Metallic communication cable test methods – Part 4-12: Electromagnetic compatibility (EMC) – Coupling attenuation or screened attenuation of connecting hardware – Absorbing clamp method*

ISO/IEC TR 14763-2:2000, *Information technology – Implementation and operation of customer premises cabling – Part 2: Planning and installation*

ISO/IEC 14763-3, *Information technology – Implementation and operation of customer premises cabling – Part 3: Testing of optical fibre cabling*

ISO/IEC 15018, *Information technology – Generic cabling for homes*

<https://standards.iteh.ai/catalog/standards/sist/04448a83-47f4-4525-9034-1c81e010-1ec-11801-2002/Amend-2-2010>

ISO/IEC 18010, *Information technology – Pathways and spaces for customer premises cabling*

ISO/IEC TR 24750:2007, *Information technology – Assessment and mitigation of installed balanced cabling channels in order to support 10GBASE-T*

ITU-T Recommendation O.9: *Measuring arrangements to assess the degree of unbalance about earth*

3.1 Terms and definitions

Add the following new terms and definitions:

3.1.84

cabled optical fibre category

system of defining requirements for the cabled optical fibre performance within optical fibre cabling channels and links

NOTE Also referred to as performance codes in some standards.⁹

3.1.85

equipment interface

location where a connection between equipment and the cabling system occurs

⁹ Standards developed by IEC subcommittee 86C use this definition in support of JTC 1/SC25 standards.

3.1.86**test interface**

location where a connection between test equipment and the cabling to be tested occurs

3.1.74

Replace, in ISO/IEC 11801:2002, the existing definition 3.1.56 for the term “small form factor connector” (renumbered as 3.1.74 by Amendment 1:2008) by the following:

3.1.74**small form factor connector**

optical fibre connector designed to accommodate two or more optical fibres with at least the same mounting density as achievable within the IEC 60603-7 series

3.2 Abbreviations

Add the following new abbreviations:

EI Equipment interface

TI Test interface

4 Conformance¹⁰

Replace, in Amendment 1:2008, point 2) of item b) by the following:

- 2) attachment of appropriate components to a permanent link or CP link design meeting the prescribed performance class of Clause 6 and Annex A. Channel performance shall be ensured where a channel is created by adding more than one cord to either end of a link meeting the requirements of Annex A;

Delete, in Amendment 1:2008, the following text and referenced footnote:

Until amendment 2⁴ of ISO/IEC 11801:2002 has been published:

- conformance for Classes D, E and F with regards to TCL, ELTCTL and coupling attenuation can only be achieved by option 1) above;
- conformance for Classes E_A and F_A can only be achieved by option 1) above.

Add, after bullet h), the following text:

Test methods to assess conformance with the channel and link requirements of Clause 6 and Annex A respectively are specified in IEC 61935-1 for balanced cabling and ISO/IEC 14763-3 for optical fibre cabling. The treatment of measured results that fail to meet the requirements of Clause 6 and Annex A respectively, or lie within the relevant measurement accuracy, shall be clearly documented within a quality plan as described in ISO/IEC 14763-2.

Installation and administration of cabling in accordance with this International Standard shall be undertaken in accordance with ISO/IEC 14763-2.

This International Standard does not specify which tests and sampling levels should be adopted. The test parameters to be measured and the sampling levels to be applied for a particular installation shall be defined in the installation specification and quality plans for that installation prepared in accordance with ISO/IEC 14763-2.

¹⁰ The entire Clause 4 of ISO/IEC 11801:2002, has been replaced by Amendment 1:2008.

5.5 Accommodation of functional elements

Replace, in ISO/IEC 11801:2002, the second sentence of the second paragraph beginning with “Guidance for ...” by the following:

Requirements for the accommodation of distributors are given in ISO/IEC 14763-2 (first edition). Until ISO/IEC 14763-2 is published, relevant information can be found in ISO/IEC TR 14763-2.

Replace, in ISO/IEC 11801:2002, the second sentence of the third paragraph beginning with “Requirements for ...” by the following:

Requirements for pathways and cable management systems are provided in ISO/IEC 14763-2 (first edition). Until ISO/IEC 14763-2 is published, relevant information can be found in ISO/IEC 18010.

5.6.1 Equipment interfaces and test interfaces

Replace, in ISO/IEC 11801:2002, the existing Figure 7 by the following new Figure 7:

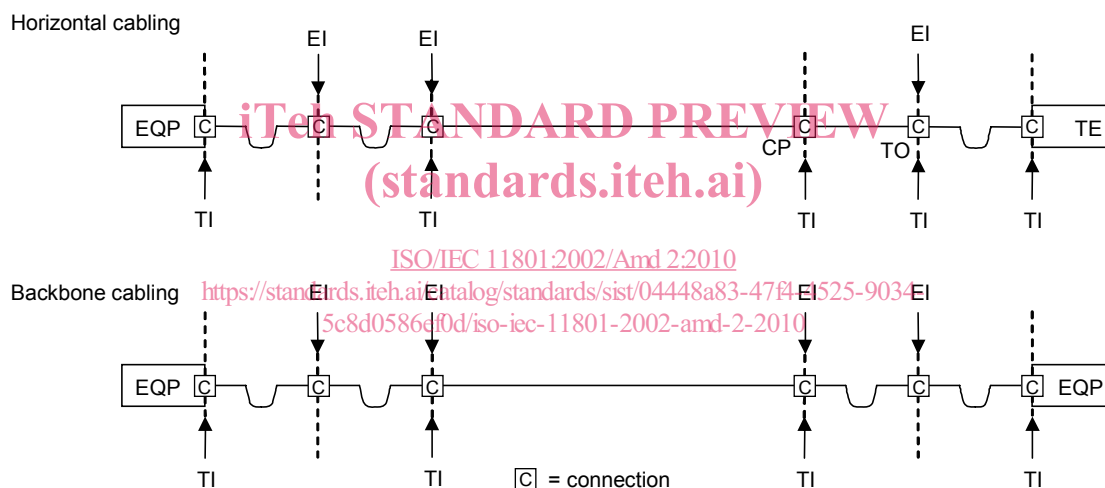

Key
 EI Equipment interface
 TI Test interface

Figure 7 – Equipment and test interfaces

5.6.2 Channel and permanent link

Replace, in ISO/IEC 11801:2002, the existing first paragraph of by the following:

The transmission performance of generic cabling is detailed in Clauses 6, 8 and Annex A, in terms of the channel and the permanent link.

5.7.5.1 General requirements

Replace, in ISO/IEC 11801:2002, the second sentence of the first bullet point by the following:

Requirements on work area size are given in ISO/IEC 14763-2 (first edition). Until IEC 14763-2 is published, relevant information can be found in ISO/IEC TR 14763-2.

Replace the last paragraph by the following:

For balanced cables, 2 pairs per TO may be used as an alternative to 4 pairs. However, this may require pair reassignment and will not support some applications (see Annex F). Care should be taken that the initial pair assignment, and all subsequent changes, are recorded (see ISO/IEC 14763-2 for details of administration requirements. Until ISO/IEC 14763-2 (first edition) is published, relevant information can be found in ISO/IEC TR 14763-2). Pair reassignment by means of inserts is allowed.

5.7.6 Consolidation point

Replace, in ISO/IEC 11801:2002, the existing text of bullet point d) by “void”.

6.2 Layout

Delete, in Amendment 1:2008, the NOTE which reads:

NOTE Component performance requirements for Category 6_A and Category 7_A will be available in Amendment 2 to ISO/IEC 11801:2002.

Delete, in ISO/IEC 11801:2002, the entire fourth paragraph beginning with “Most Class F channels...”.

Replace, in ISO/IEC 11801:2002, the existing paragraph prior to Figure 11, as well as Figure 11 by the following:

Figure 11 shows an example of terminal equipment in the work area connected to transmission equipment using two different media channels which are cascaded. In fact, there is an optical fibre cabling channel (see Clause 8) connected via an active component in the FD to a balanced cabling channel. There are four channel interfaces; one at each end of the balanced channel and one at each end of the optical fibre cabling channel.

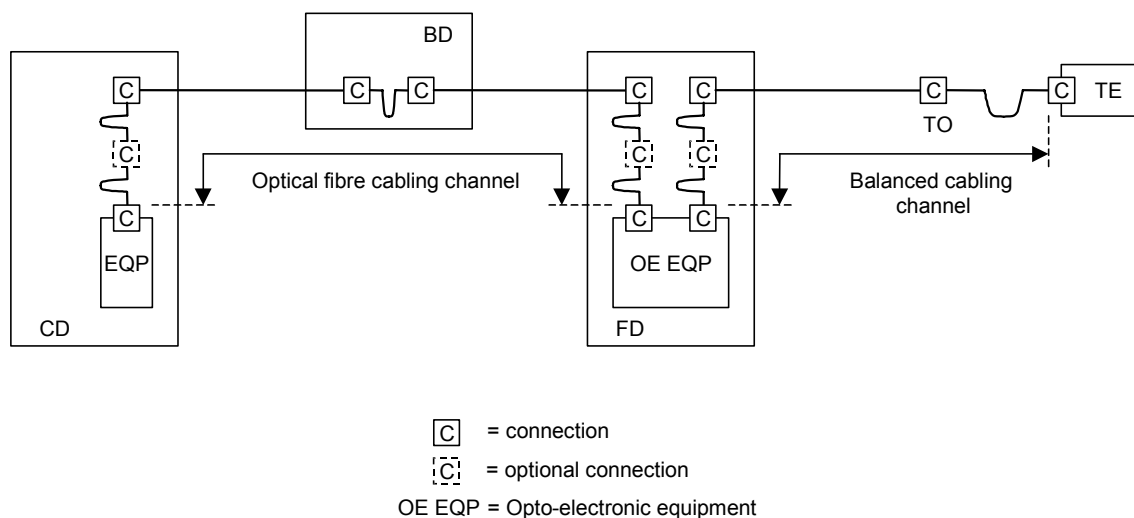

Figure 11 – Example of a system showing the location of cabling interfaces and extent of associated channels

Delete, in Amendment 1:2008, the NOTE which reads:

NOTE Permanent link and CP link requirements for Class E_A and Class F_A will be available in amendment 2 to ISO/IEC 11801:2002.

Delete, in ISO/IEC 11801:2002, the entire last paragraph beginning with “Most Class F channels...”.

6.3 Classification of balanced cabling

Replace, in ISO/IEC 11801:2002, the second sentence of the second paragraph by the following:

Similarly, Class B, C, D, E, E_A, F and F_A channels provide the transmission performance to support Class B, C, D, E, E_A, F and F_A applications respectively.

6.4.2 Return loss

Replace, in ISO/IEC 11801:2002, the existing first paragraph by the following:

The return loss requirements are applicable to Classes C, D, E, E_A, F and F_A only.

6.4.3 Insertion loss/attenuation

Replace, in ISO/IEC 11801:2002, the last paragraph before Table 4 by the following:

When required, the insertion loss shall be measured according to IEC 61935-1.

6.4.5.1 General

[ISO/IEC 11801:2002/Amd 2:2010](https://standards.iteh.ai/catalog/standards/sist/04448a83-47f4-4525-9034-310e81111111/iso-11801-2002/amd-2-2010)

[https://standards.iteh.ai/catalog/standards/sist/04448a83-47f4-4525-9034-](https://standards.iteh.ai/catalog/standards/sist/04448a83-47f4-4525-9034-310e81111111/iso-11801-2002/amd-2-2010)

Replace, in Amendment 1:2008, the entire text of this subclause by the following:

ACR-N and PS ACR-N requirements are applicable to Classes D, E, E_A, F and F_A only.

Except for the name, the definition and equations for ACR-N and PS ACR-N are identical to those used for ACR and PS ACR, respectively, in prior editions of this standard.

6.4.6.1 General

Replace, in Amendment 1:2008, the first paragraph by the following:

ACR-F and PS ACR-F requirements are applicable to Classes D, E, E_A, F and F_A only.

6.4.9 Current carrying capacity

Replace, in ISO/IEC 11801:2002, the existing subclause by the following:

The minimum current carrying capacity for channels of Classes D, E, E_A, F and F_A shall be 0,175 A d.c. per conductor for all temperatures at which the cabling will be used. This shall be achieved by an appropriate design.

For information on current carrying capacity in respect to applications using remote power supplied over balanced cabling, see ISO/IEC TR 29125.

6.4.13 Delay skew

Replace, in ISO/IEC 11801:2002, the existing second paragraph by the following:

When required, the delay skew shall be calculated according to IEC 61935-1.

6.4.15.5 PS AFEXT for Class E_A channels

Replace, in Amendment 1:2008, the existing third paragraph by the following:

The measured pair-to-pair AFEXT values of a wire pair k in a disturbed channel from the disturbing channel l are normalized by the difference of the insertion losses of disturbing and disturbed channels.

7.1 General

Replace, in ISO/IEC 11801:2002, the existing text by the following:

This clause describes implementations of generic balanced cabling that utilise components and assemblies referenced in Clauses 9, 10 and 13. These reference implementations meet the requirements of Clause 5, and when installed in accordance with ISO/IEC 14763-2 (until ISO/IEC 14763-2 is published, relevant information can be found in ISO/IEC TR 14763-2), comply with the channel performance requirements of Clause 6.

7.2.1 General

Replace, in ISO/IEC 11801:2002, the first paragraph by the following:

Balanced components referenced in Clauses 9 and 10 are defined in terms of impedance and category. In the reference implementations of this clause, the components used in each cabling channel shall have the same nominal impedance in accordance with 9.2.

7.2.2.1 Component choice

Replace, in Amendment 1 to ISO/IEC 11801:2008, the existing bullet points for Category 6_A and Category 7_A by the following:

- Category 6_A components provide Class E_A balanced cabling performance;
- Category 7_A components provide Class F_A balanced cabling performance;

7.2.2.2 Dimensions

Replace, in ISO/IEC 11801:2002, the existing Figure 12 by the following:

a) Interconnect - TO Model

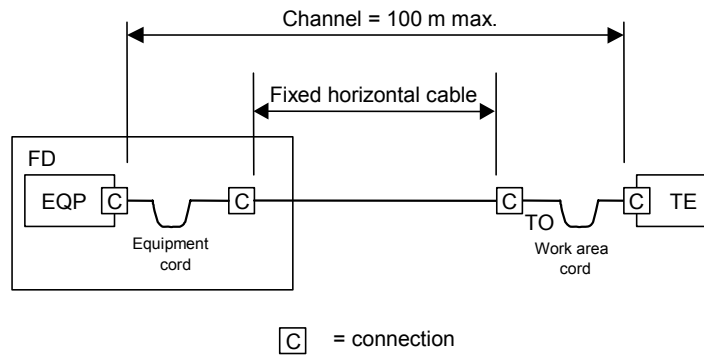

b) Crossconnect - TO Model

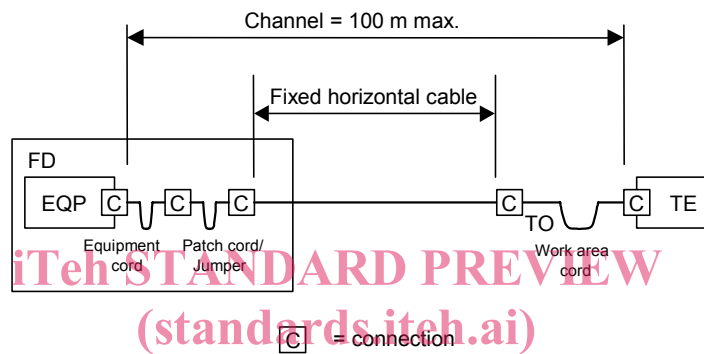

c) Interconnect - CP - TO Model
<https://standards.iteh.ai/catalog/standards/sist/04448a83-47f4-4525-9034-5c8d0586ef0d/iso-11801-2-2010>

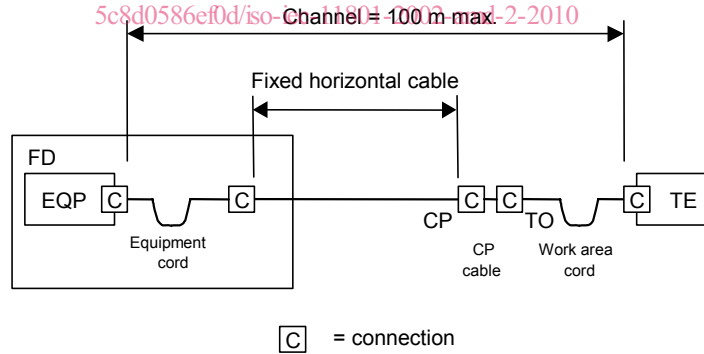

d) Crossconnect - CP - TO Model

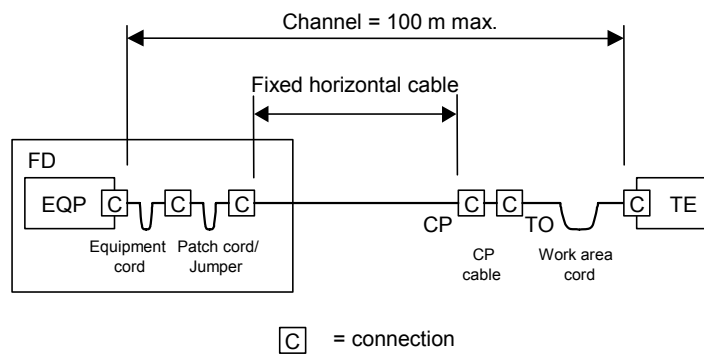

Figure 12 – Horizontal cabling models

7.2.2.2 Dimensions

Replace, in Amendment 1:2008, the existing paragraph before Table 31 by the following:

Table 31 contains the length assumptions of the mathematical model used to validate channel performance using components of Clauses 9, 10 and 13. They do not represent absolute restrictions on the implementation of channels and permanent links, but may be used for guidance in reference implementations.

Table 31¹¹

Replace, in Amendment 1:2008, the table title by the following:

Table 31 – Length assumptions used in the mathematical modelling of balanced horizontal cabling

Add, in Amendment 1:2008, the following text before Table 32:

In addition to the cords, the channels shown in Figure 12c and Figure 12d contain a CP cable. The insertion loss specification for the CP cable may differ from that of both the fixed horizontal cable and the cords. In order to accommodate cables used for work area cords, CP cables, patch cords, jumpers and equipment cords with different insertion loss, the length of the cables used within a channel shall be determined by the equations shown in Table 32.

Replace, in Amendment 1:2008, Table 32 by the following:
(Note that Table 21 in ISO/IEC 11801:2002 has been replaced and renumbered by Amendment 1:2008 as Table 32.)

ISO/IEC 11801:2002/Amd 2:2010
Table 32 – Horizontal channel length equations
<https://standards.iteh.ai/catalog/standards/sis/04446a85-4714-4525-9034-5c8d0586e10d/iso-iec-11801-2002-amd-2-2010>

Model	Figure	Implementation equation		
		Class D	Class E and E _A	Class F and F _A
Interconnect - TO	12a	$H = 109 - FX$	$H = 107 - 3^a - FX$	$H = 107 - 2^a - FX$
Cross-connect - TO	12b	$H = 107 - FX$	$H = 106 - 3^a - FX$	$H = 106 - 3^a - FX$
Interconnect - CP -TO	12c	$H = 107 - FX - CY$	$H = 106 - 3^a - FX - CY$	$H = 106 - 3^a - FX - CY$
Cross-connect - CP - TO	12d	$H = 105 - FX - CY$	$H = 105 - 3^a - FX - CY$	$H = 105 - 3^a - FX - CY$
<i>H</i> the maximum length of the fixed horizontal cable (m) <i>F</i> combined length of patch cords/jumpers, equipment and work area cords (m) <i>C</i> the length of the CP cable (m) <i>X</i> the ratio of cord cable insertion loss (dB/m) to fixed horizontal cable insertion loss (dB/m) <i>Y</i> the ratio of CP cable insertion loss (dB/m) to fixed horizontal cable insertion loss (dB/m)				
NOTE For operating temperatures above 20 °C, H should be reduced by 0,2 % per °C for screened cables; 0,4 % per °C (20 °C to 40 °C) and 0,6 % per °C (>40 °C to 60 °C) for unscreened cables.				
^a This length reduction is to provide an allocated margin to accommodate insertion loss deviation.				

Move, in Amendment 1:2008, after Table 32 the following text above the bulleted list:

For the purpose of calculation in Table 32 it is assumed that:

¹¹ Refers to Table 31 as added by Amendment 1 and not Table 31 (renumbered as Table 42 by Amendment 1:2008) in ISO/IEC 11801:2002.