



# Standard Practice for Receipt, Storage, and Handling of Fuels for Gas Turbines<sup>1</sup>

This standard is issued under the fixed designation D 4418; the number immediately following the designation indicates the year of original adoption or, in the case of revision, the year of last revision. A number in parentheses indicates the year of last reapproval. A superscript epsilon ( $\epsilon$ ) indicates an editorial change since the last revision or reapproval.

## 1. Scope

1.1 This practice covers the receipt, storage, and handling of fuels for gas turbines, except for gas turbines used in aircraft. It is intended to provide guidance for the control of substances in a fuel that could cause deterioration of either the fuel system, or the gas turbine, or both.

1.2 This practice provides no guidance for either the selection of a grade of fuel, a topic covered by Specification D 2880, or for the safety aspects of the fuel and fuel systems. For example, this practice does not address the spacings of storage tanks, loading and unloading facilities, etc., and procedures for dealing with the flammability and toxic properties of the fuels.

1.3 The values stated in SI units are to be regarded as the standard. The values given in parentheses are for information only.

1.4 *This standard does not purport to address all of the safety concerns, if any, associated with its use. It is the responsibility of the user of this standard to establish appropriate safety and health practices and determine the applicability of regulatory limitations prior to use.*

## 2. Referenced Documents

### 2.1 ASTM Standards:

- D 1500 Test Method for ASTM Color of Petroleum Products (ASTM Color Scale)<sup>2</sup>
- D 1796 Test Method for Water and Sediment in Fuel Oils by the Centrifuge Method (Laboratory Procedure)<sup>2</sup>
- D 2274 Test Method for Oxidation Stability of Distillate Fuel Oil (Accelerated Method)<sup>2</sup>
- D 2276 Test Methods for Particulate Contaminant in Aviation Fuel by Line Sampling<sup>2</sup>
- D 2880 Specification for Gas Turbine Fuel Oils<sup>2</sup>
- D 4057 Practice for Manual Sampling of Petroleum and Petroleum Products<sup>3</sup>

<sup>1</sup> This practice is under the jurisdiction of ASTM Committee D02 on Petroleum Products and Lubricants and is the direct responsibility of Subcommittee D02.02 on Burner, Diesel, and Gas Turbine Fuel Oils.

Current edition approved Dec. 10, 2000. Published January 2001. Originally published as D 4418 – 84. Last previous edition D 4418 – 88(1998).

<sup>2</sup> *Annual Book of ASTM Standards*, Vol 05.01.

<sup>3</sup> *Annual Book of ASTM Standards*, Vol 05.02.

D 6469 Guide for Microbial Contamination in Fuels and Fuel Systems<sup>4</sup>

## 3. Terminology

3.1 *fuel entering the combustor(s)*—this term is used to designate the fuel that is actually burned in the gas turbine. Fuel may actually be sampled at a point upstream from the point of entry into the combustor(s), provided the sample is representative of the fuel actually entering the combustor(s).

3.2 *fuel contaminants*—in principle, are any fuel component other than hydrocarbon oils. In the present context the contaminants are foreign materials that make the fuel less suitable or even unsuitable for the intended use. The contaminants of primary interest are foreign materials introduced subsequent to the manufacture of specification quality fuel. Hence they are materials introduced in the distribution system (that is storage tanks, pipelines, tank, trucks, barges, etc.), or in the user's storage and handling systems, or generated within these systems (rust generated in steel pipes and tanks by moist fuel, etc.). Contaminants may be soluble or insoluble in the fuel.

3.3 *dissolved and free water*—water may be present in the fuel as dissolved water or as “free” (undissolved) water, or both. The free water may be fresh or saline. Fresh water may enter the fuel from steam coils in storage tanks, from condensation out of moisture-laden air, or from leaking cooling coils. Saline water can enter the fuel during transportation in barges or tankers.

3.4 *particulate solids*—may enter a fuel from the air (suspended dirt and aerosols) or from the distribution and storage systems (rust, corrosion products, gasket debris, and so forth).

3.5 *metallic compounds*—metals may be present as metallic compounds in the fuel as a natural result of the composition of the crude oil and of the refining process. However, unless special precautions are taken, additional metallic compounds can be acquired during distribution and storage. A commercial product pipeline may contain residues of lead-containing gasoline that would then be dissolved by the gas turbine fuel. Tank trucks, railroad tankcars, barges, and tankers may be inadequately cleaned and contain residues of past cargos.

<sup>4</sup> *Annual Book of ASTM Standards*, Vol 05.04.

Acidic components in saline water salts in the fuel may react with distribution and storage equipment.

3.6 *microbial slimes*—may result when conditions are conducive to the growth of microorganisms that are always present. The presence of free water is essential to the growth of many of these microorganisms that grow in tank water bottoms and feed on nutrients in the water or on the hydrocarbons.

#### 4. Summary of Practice

4.1 The body of this practice defines the contaminants frequently found in turbine fuel oils and discusses the sources and significance of such contaminants.

4.2 Annex A1 is a guide for the receipt, storage, and handling of distillate gas turbine fuels, Grades 1-GT and 2-GT, in accordance with Specification D 2880.

4.3 Annex A2 is a guide for the receipt, storage, and handling of gas turbine fuels, Grades 3-GT and 4-GT, that contain residual components.

4.4 Annex A3 is a guide for the selection and storage of fuels intended for long-term storage, when such fuels are distillate fuels.

4.5 Annex A4 is a guide for gas turbine users who are considering the use of fuels from alternative non-petroleum sources.

#### 5. Significance and Use

5.1 This practice provides the user of gas turbine fuel oils and the designer of gas turbine fuel systems with an appreciation of the effects of fuel contaminants and general methods of controlling such contaminants in gas turbine fuel systems.

5.2 This practice is general in nature and should not be considered a substitute for any requirement imposed by warranty of the gas turbine manufacturer, or by federal, state, or local government regulations.

5.3 Although it cannot replace a knowledge of local conditions or the use of good engineering and scientific judgment, this practice does provide guidance in development of individual fuel management systems for the gas turbine user.

#### 6. Significance of Contaminants

6.1 Contamination levels in the fuel entering the combustor(s) must be low for improved turbine life. Low contamination levels in the fuel in the turbine's in-plant fuel system are required to minimize corrosion and operating problems. Providing fuel of adequate cleanliness to the gas turbine combustor(s) may require special actions by the user. These actions might include special transportation arrangements with the fuel supplier, particular care in on-site fuel storage and quality control procedures, and establishment of on-site cleanup procedures. Each of the four classes of contaminants defined in 3.2 has its own significance to system operation.

6.1.1 Water will cause corrosion of tanks, piping, flow dividers, and pumps. Corrosion or corrosion products in close-tolerance devices, such as flow dividers, may cause plugging and may stop flow to the turbines. Free water is potentially corrosive in sulfur-containing fuels, it may be particularly corrosive. Free water may contain dissolved salts that may be corrosive, and may encourage microbiological growth.

6.1.2 Particulate solids may shorten the life of fuel system components. Life of fuel pumps and of various close-tolerance devices is a function of particulate levels and size distributions in the fuel. High levels of particulates can lead to short cycle times in the operation of filters, filter/separators, centrifuges, and electrostatic purifiers. Since such separation devices do not remove all the particulates, certain quantities will be present in the down-stream fuel.

6.1.3 Trace metals refer both to those metals present as metallic compounds in solution and to metals present in particulates like rust. They are dissolved or suspended either in the fuel hydrocarbons or in free water present in the fuel. The significance of several individual trace metals with respect to hot corrosion is discussed in 6.1.4 through 6.1.5. Although lower levels of trace metals in a fuel will promote longer turbine service from a corrosion standpoint, the specification of excessively low levels may limit the availability of the fuel or materially increase its cost. Table 1 suggests levels of trace metals that would probably yield satisfactory service.

6.1.4 Ash is the noncombustible material in an oil. Ash-forming materials may be present in fuel oil in two forms: (1) solid particles, and (2) oil- or water-soluble metallic compounds. The solid particles are for the most part the same material that is designated as sediment in the water and sediment test. Depending on their size, these particles can contribute to wear in the fuel system and to plugging of the fuel filter and the fuel nozzle. The soluble metallic compounds have little or no effect on wear or plugging, but they can contain elements that produce turbine corrosion and deposits as described in 6.1.5.

6.1.5 *Vanadium and Lead*—Fuel contaminants might include soluble compounds such as vanadium porphyrins, metallic soaps, or tetraethyl lead that cannot be removed from the fuel at the gas-turbine site.

6.1.5.1 Vanadium can form low melting compounds such as vanadium pentoxide which melts at 691°C (1275°F), and causes severe corrosive attack on all of the high-temperature alloys used for gas-turbine blades. If there is sufficient magnesium in the fuel, it will combine with the vanadium to form compounds with higher melting points and thus reduce the corrosion rate to an acceptable level. The resulting ash will form deposits in the turbine and will require appropriate cleaning procedures.

6.1.5.2 When vanadium is present in more than trace amounts either in excess of 0.5 ppm or a level recommended by the turbine manufacturer, it is necessary to maintain a weight ratio of magnesium to vanadium in the fuel of not less than 3.0 in order to control corrosion.

**TABLE 1 Trace Metal Limits of Fuel Entering Turbine Combustor(s)**

Designation	Trace Metal Limits by Weight, max, ppm			
	Vanadium	Sodium plus Potassium	Calcium	Lead
No. 0-GT	0.5	0.5	0.5	0.5
No. 1-GT	0.5	0.5	0.5	0.5
No. 2-GT	0.5	0.5	0.5	0.5
No. 3-GT	0.5	0.5	0.5	0.5
No. 4-GT	(Consult turbine manufacturers)			

6.1.5.3 An upper limit of 3.5 is suggested since larger ratios will lead to unnecessarily high rates of ash deposition. In most cases, the required magnesium-to-vanadium ratio will be obtained by additions of magnesium-containing compounds to the fuel oil. The special requirements covering the addition and type of magnesium-containing additive, or equivalent, shall be specified by mutual agreement between the various interested parties. The additive will vary depending on the application, but it is always essential that there is a fine and uniform dispersion of the additive in the fuel at the point of combustion.

6.1.5.4 For gas turbines operating at turbine-inlet gas temperatures below 650°C (1200°F), the corrosion of the high-temperature alloys is of minor importance, and the use of a silicon-base additive will further reduce the corrosion rate by absorption and dilution of the vanadium compounds.

6.1.5.5 Lead can cause corrosion, and in addition it can spoil the beneficial inhibiting effect of magnesium additives on vanadium corrosion. Since lead is only rarely found in significant quantities in crude oils, its appearance in the fuel oil is primarily the result of contamination during processing or transportation.

6.1.6 *Sodium, Potassium, and Calcium*—Fuel contaminants might also include fuel-insoluble materials such as water, salt, or dirt, potential sources of sodium, potassium, and calcium. These are normally removed at the gas-turbine site, unless such contaminants are extremely finely divided.

6.1.6.1 *Sodium and Potassium* can combine with vanadium to form eutectics that melt at temperatures as low as 566°C (1050°F) and can combine with sulfur in the fuel to yield sulfates with melting points in the operating range of the gas turbine. These compounds produce severe corrosion, and for turbines operating at gas inlet temperatures above 650°C (1200°F), additives are not yet in general use that control such corrosion.

6.1.6.2 Accordingly, the sodium-plus-potassium level must be limited, but each element is measured separately. Some gas turbine installations incorporate systems for washing oil with

water to reduce the sodium-plus-potassium level. In installations where the fuel is moved by sea transport, the sodium-plus-potassium level should be checked prior to use to ensure that the oil has not become contaminated with sea salt. For gas turbines operating at turbine inlet gas temperatures below 650°C (1200°F), the corrosion due to sodium compounds is of minor importance and can be further reduced by silicon-base additives. A high sodium content is even beneficial in these turbines because it increases the water-solubility of the deposits and thereby increases the ease with which gas turbines can be water-washed to obtain recovery of the operating performance.

6.1.6.3 *Calcium*—Calcium is not harmful from a corrosion standpoint: in fact, it serves to inhibit the corrosive action of vanadium. However, calcium can lead to hard-bonded deposits that are not self-spalling when the gas turbine is shut down, and are not readily removed by water washing of the turbine. The fuel-washing systems, used at some gas turbine installations to reduce the sodium and potassium level, will also significantly lower the calcium content of fuel oil.

6.1.7 *Microbial Slimes*—Microbial slimes caused by microorganisms can plug filters and other close-tolerance openings. Some organisms can cause corrosion as well as produce slimes. Under anaerobic conditions, hydrogen sulfide, which may cause corrosion, can be generated by biological action. Biocides are available for controlling the growth of microorganisms, but their effect on trace metal levels and other fuel properties should be considered. Since water is required for the growth of the microorganisms, one way of controlling their growth is to eliminate the presence of water through tank-stripping operations or other separation techniques. Refer to Guide D 6469 for a more complete discussion.

## 7. Keywords

7.1 contaminants; fuel handling; fuel storage; gas turbine fuels

## ANNEXES

### (Mandatory Information)

#### A1. PRACTICE FOR THE RECEIPT, STORAGE, AND HANDLING OF DISTILLATE TURBINE FUELS

##### A1.1 Scope

A1.1.1 This practice covers the receipt, storage, and handling of distillate gas turbine fuels, Grades 1-GT and 2-GT, purchased in accordance with Specification D 2880.

A1.1.2 This practice may also be used as a guideline for the receipt, storage, and handling of gas turbine fuel, Grade 0-GT, purchased in accordance with Specification D 2880, but only if modifications are made to take into account the volatile nature of Grade 0-GT fuel. Those modifications are not specified in this practice.

A1.1.3 This practice provides guidance in developing an individual fuel management system for the gas-turbine user. It

includes suggestions for the operation and maintenance of existing fuel storage and handling facilities, and for identifying where, when, and how fuel quality should be monitored.

##### A1.2 Terminology

A1.2.1 *fuel storage system*—Fig. A1.1 is a generalized fuel storage system for use with distillate fuels, Grades 1-GT and 2-GT, conforming to Specification D 2880. It consists of the tankage, piping, fittings, and separation equipment between the point of connection with the delivery truck, railroad car, or other transportation equipment and the point where the fuel enters the gas turbine combustor(s). The specific configuration

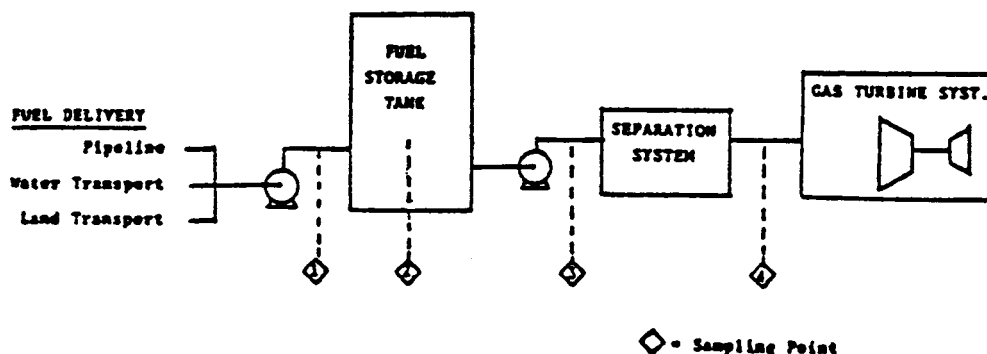

FIG. A1.1 Distillate Fuel Storage and Handling System (Gas Turbine Fuels Grades 1-GT and 2-GT)

of components will vary with the manufacturer's and the user's preference for one type of equipment over another, for example, a centrifugal purifier over a coalescing filter/separator. Thus, Fig. A1.1 is merely a guide for discussion and illustration.

A1.2.2 *separation system*—includes equipment for removing foreign materials, for example, water and solids, from fuels. Fuel storage tanks may serve simultaneously as separators, since contaminants can settle to the bottom of such tanks under the influence of gravity. Other commonly used separators are the various types of filters, centrifuges, and electrostatic separators.

A1.2.2.1 *filters*—devices for separating suspended matter from the fuel by passing the fuel through a porous medium.

A1.2.2.2 *screens*—filters designed for the separation of relatively coarse material from the fuel. They are commonly used to remove such materials as rags, weld material, gasket pieces, and other debris from the fuel ahead of a pump, that could be harmed if such debris were to reach the pump.

A1.2.2.3 *mechanical or edge filters*—filters consisting of stacks of metal disks separated at precise intervals by spacer plates. The liquid to be filtered flows radially between the disks removing the particles on the edges. These filters may be cleaned on-line manually or automatically to remove accumulated solids.

A1.2.2.4 *cartridge filters*—filters that use one or more replaceable or renewable cartridges containing the filter medium. Such filters may use elements of fiber, resin-impregnated (often pleated) filter paper, porous stone, or porous stainless steel of controlled porosity.

A1.2.2.5 *coalescing filter/separators*—usually cartridge filters that can remove water as well as particulate solids. The fine droplets of water in a fuel are coalesced into larger drops that are separated by the effect of gravity. Such filters are also termed coalescers, separator filters, and filter/separators.

A1.2.2.6 *depth-type filters*—consist of beds of fine, sometimes graded, solids such as sand. Sometimes clay beds are used to provide adsorptive properties as well as filtration. Salt towers are a specialized class of depth filters for removal of water.

A1.2.2.7 *centrifuge*—a rotating mechanical device for separating solids from liquids and immiscible liquids from each other. When used for fuel or lubricant purification, they are sometimes called centrifugal purifiers or simply purifiers.

A1.2.2.8 *electrostatic separators*—use electrostatic forces to separate water or solids, or both, from a liquid fuel. These include electric desalters that are commonly used to remove saline water from crude petroleum oil prior to distillation.

A1.2.3 *the user's fuel quality control system*—consists of the user's sampling policies and procedures, associated test, and examination procedures. Use of this system establishes the conformity of the fuel to purchase agreements, and ensures that the quality of fuel in storage and as-delivered to the gas-turbine combustors conforms to the necessary quality standards.

### A1.3 Summary of Practice

A1.3.1 Sampling and inspection of the fuel should be done upon receipt at the user site, and periodically thereafter at specified locations and times to identify contaminated or otherwise unsatisfactory fuel before it reaches the combustor(s).

A1.3.2 Fuel system components should be cleaned and maintained either periodically or on the basis of operational evidence (pressure drop across a filter), or on a combination of the two.

### A1.4 Significance and Use

A1.4.1 The use of fuel-system monitoring and quality control techniques, combined with scheduled cleaning and maintenance, will minimize the quantity of contaminants reaching the combustor(s) and hence will minimize corrosion and erosion of gas turbine components.

A1.4.2 The use of fuel monitoring, storage, and handling techniques will limit water, suspended solids, and microbial growth in the fuel; this in turn will minimize corrosion and erosion of gas turbine components.

### A1.5 Sampling

A1.5.1 Samples should be taken at each of the four points as in Fig. A1.1. Consult Practice D 4057, for sampling procedures.

A1.5.1.1 A sample should be taken at point 1, on delivery, during transfer into the storage tank.

A1.5.1.2 Fuel storage tank samples should include both tank bottom samples and "all-level" samples. These samples shall be taken at a frequency to be determined by the user based on the rate of accumulation of water and other contaminants. When the system consists of multiple tankage, take these



samples preparatory to drawing fuel from a given tank. When the gas turbine is used for infrequent standby or emergency service, take the sample on a closely observed schedule.

A1.5.1.3 Sampling at points three and four is essential to determine the effectiveness of the separation system, if any, and to assure the quality of the fuel being supplied to the gas turbine. The frequency of such sampling should be determined by the user's experience and in consultation with the turbine manufacturer.

### A1.6 Inspection and Analysis of Samples

A1.6.1 Inspection and analysis of fuel is very important in determining fuel quality at various locations and times in the fuel storage and handling system and will ensure that only fuel of acceptable quality will reach the turbine combustor(s). Brief and visual methods may serve to suggest the presence of some contaminants, but established fuel analysis methods including chemical analysis for trace elements are needed for more complete judgement of fuel quality.

A1.6.2 The effectiveness of a fuel separation system may best be judged by the use of specialized analytical methods, as recommended by the equipment suppliers or by fuel vendors. These might include conductivity, dielectric properties, color, content and quality of particulates, turbidity, spectral properties, or filterability. From such data, useful inferences may be derived to supplement more detailed chemical analysis.

### A1.7 Cleaning and Maintenance

A1.7.1 A relatively long residence of fuel in tankage allows separation of insoluble contaminants, especially water and inorganic solids. Accumulation of water can generate corrosion product solids and biological slimes. These materials can result in gradual or sudden overloading of separation equipment and possibly the erosion or plugging of close-tolerance devices such as fuel pumps and flow dividers.

A1.7.1.1 Water as a separate phase mobilizes oxygen and acidity to effect corrosion or simple rusting of tank metal surfaces, and gives a medium for biological slime development. The rate of accumulation of water and its products in fuel tank bottoms can be established by appropriate samples at point 2. A schedule of tank stripping should be established to maintain water at a low level. Careful, slow drawoff rates enable more complete stripping.

A1.7.1.2 Rust or other inorganic debris present in tank bottom from previous corrosion, from peeling of possible protective coatings, or from tank scale deposits should be

removed by appropriate cleaning procedures to prevent downstream damage. Chronic recurrence of these problems may best be solved by use of special corrosion inhibitors, by incorporation of tank linings, or by substitution of tankage with better corrosion resistance.

A1.7.2 The role of separation systems in removing contaminants inevitably involves the fouling of such equipment with debris. In order to sustain effective operation, proper maintenance schedules for cleaning or equipment renewal must be followed.

A1.7.2.1 The proper operation of all types of fuel filters is reduced by fouling and accumulation of contaminants, resulting in reduced fuel throughput or increased pressure differentials, or both. Operation of screens and barrier filters may be restored by cleaning, for example, a back-flush sequence. Some cartridge filters cannot be back-flushed and hence must be replaced. Some coalescing filters, in addition to becoming plugged, may lose their ability to shed coalesced water droplets because of the accumulation of surfactants on their semipermeable filter media, and also must be replaced.

A1.7.2.2 The proper functioning of both centrifugal and electrostatic separators is compromised to some degree by the accumulation of solid or semisolid debris, that makes small but important changes in internal geometry. The extent of these effects and the rate at which they occur depend on the type and level of contamination in fuels. These malfunctions are manifested in a reduced ability to remove water and particulate matter (see A1.6.2). In both types of equipment, purging sequences for removal of such debris are possible during operation, but thorough cleaning at longer intervals is also advisable to restore design efficiency.

### A1.8 Documentation

A1.8.1 In view of the critical requirements for safe and efficient operation, an adequate record to provide evidence of the amount, type, and quality of fuel burned in the gas turbine is important to trace the causes of unusual maintenance problems and to assess the performance of the fuel storage and separation facilities. These records also serve to help the user decide what frequency of sampling and maintenance operations are required. Such a record should include the date, time, and location of all samples, fuel source, flow rate, the record of measurements and analyses performed, and pertinent information relevant to the condition and operation of fuel tankage and contaminant-separation equipment.

## A2. PRACTICE FOR THE RECEIPT, STORAGE, AND HANDLING OF TURBINE FUELS CONTAINING RESIDUAL COMPONENTS

### A2.1 Scope

A2.1.1 This practice covers the receipt, storage, handling, and chemical treatment of gas turbine fuels, Grades 3-GT and 4-GT, in accordance with Specification D 2880. Grade 3-GT fuel may contain residual components, and Grade 4-GT fuel is defined as one containing residual components.

A2.1.2 This practice provides guidance in the operation and maintenance of fuel systems serving gas-turbine installations based on Grades 3-GT or 4-GT fuel. They identify where, when, and how fuel quality should be monitored; and when and how equipment should be cleaned and maintained. Further they provide guidelines for the washing and chemical treatment of

the fuels, a practice that may be beneficial with certain residual fuels to reduce certain trace metal contents.

A2.1.3 This practice is general in nature and should not be considered a substitute for requirements imposed by the warranty of the gas-turbine manufacturer or by federal, state, or local laws. This practice cannot replace a knowledge of local conditions or the application of sound engineering and scientific judgement, but it does provide guidance for the development of an individual fuel-management system for the gas turbine user.

**A2.2 Terminology**

A2.2.1 The general descriptions of systems to be used with Grades 1-GT and 2-GT fuels in accordance with Specification D 2880 in A1.2, also hold for Grades 3-GT and 4-GT ash-forming fuels but with added fuel treatment and fuel heating hardware as illustrated by the example shown in Fig. A2.1.

A2.2.2 *fuel desalting*— required for those fuels where the alkali metal content (sodium plus potassium) exceeds the limit specified by the turbine manufacturer. Most fuel must be heated to facilitate desalting. Desalting is normally accomplished by extracting the alkali-metal salts from the fuel by contacting the fuel with low-salt wash water and then mechanically removing the salt-laden water by centrifugation or electrostatic precipitation. Multiple desalting stages may be required to achieve the required reduction in salt concentration.

A2.2.3 *chemical inhibitors*—required for fuels with vanadium levels in excess of the turbine manufacturer’s specified limit. Magnesium-based inhibitors are normally used. They may be added batch-wise to the fuel as a pre-mix or injected on-line into the fuel. Silicon-based inhibitors or magnesium-silicon mixed inhibitors are used in some applications.

NOTE A2.1—Special precautions may be required to keep some inhibitors uniformly dispersed in the fuel.

A2.2.4 *combined heating and separation system*—normally required for Grades 3-GT and 4-GT fuels (Fig. A2.1). Most

ash-forming fuels require heating to lower the fuel viscosity for proper pre-combustion atomization. Grade 4-GT and some Grade 3-GT fuels require a secondary fuel for light-off and for flushing the fuel lines at shutdown. The fuel system must have a fuel transfer valve with proper controls to accomplish the transfer on start-up and shutdown. These systems generally contain filters for the removal of particulates. (Fuels containing residual components or surface active agents, such as in 3-GT and 4-GT fuel, can interfere with the proper operation of coalescing filters.)

**A2.3 Summary of Practice**

A2.3.1 Sampling and inspection of the fuel should be done upon receipt at the user site, and periodically thereafter at specified locations and times to identify contaminated, improperly inhibited, or otherwise unsatisfactory fuel before it reaches the gas-turbine combustor(s).

A2.3.2 A basis for the cleaning and maintenance of fuel-system components, including both elapsed time since previous cleaning and maintenance, and operational evidence (pressure drops across filters), should be established.

A2.3.3 Guidelines are provided for the operation of washing and treating facilities sometimes used to limit hot corrosion associated with sodium-vanadium compounds deriving from residual components of heavy fuels.

**A2.4 Significance and Use**

A2.4.1 The use of fuel system monitoring and quality control techniques, combined with scheduled cleaning and maintenance will minimize the quantity of contaminants reaching the combustor(s) and hence will minimize corrosion and erosion of gas-turbine components.

A2.4.2 The use of fuel monitoring and storage and handling techniques will limit water and suspended solids; this in turn will minimize corrosion and erosion of gas turbine components.

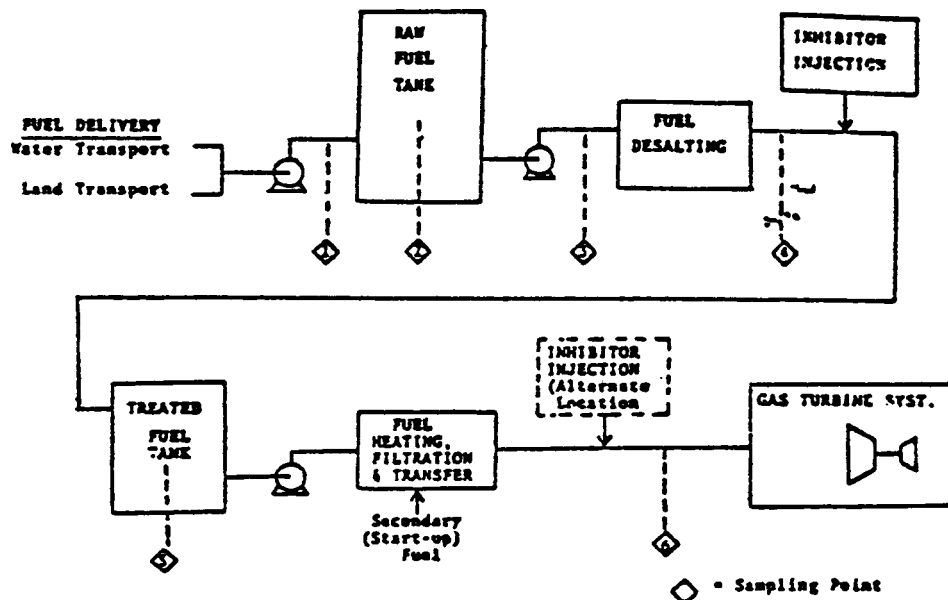

FIG. A2.1 Residual Fuel Storage, Treatment and Handling System (Gas Turbine Fuel Grade 4-GT Requiring Complete Treatment)