

INTERNATIONAL STANDARD

ISO 1074

Second edition
1991-03-15

Counterbalanced fork-lift trucks — Stability tests

iTeh STANDARD PREVIEW
Chariots élévateurs à fourche travaillant en porte-à-faux — Essais de stabilité
(standards.iteh.ai)

ISO 1074:1991

<https://standards.iteh.ai/catalog/standards/sist/614611ab-b2e5-4b40-905c-eeef6d95fd18/iso-1074-1991>



Reference number
ISO 1074 : 1991 (E)

Foreword

ISO (the International Organization for Standardization) is a worldwide federation of national standards bodies (ISO member bodies). The work of preparing International Standards is normally carried out through ISO technical committees. Each member body interested in a subject for which a technical committee has been established has the right to be represented on that committee. International organizations, governmental and non-governmental, in liaison with ISO, also take part in the work. ISO collaborates closely with the International Electrotechnical Commission (IEC) on all matters of electrotechnical standardization.

Draft International Standards adopted by the technical committees are circulated to the member bodies for voting. Publication as an International Standard requires approval by at least 75 % of the member bodies casting a vote.

International Standard ISO 1074 was prepared by Technical Committee ISO/TC 110, *Industrial trucks*, Sub-Committee SC 2, *Safety of powered industrial trucks*.

[ISO 1074:1991](#)

This second edition cancels and replaces the first edition (ISO 1074:1975); the rated capacity has been increased and the applicability range altered.

© ISO 1991

All rights reserved. No part of this publication may be reproduced or utilized in any form or by any means, electronic or mechanical, including photocopying and microfilm, without permission in writing from the publisher.

International Organization for Standardization
Case postale 56 • CH-1211 Genève 20 • Switzerland

Printed in Switzerland

Counterbalanced fork-lift trucks – Stability tests

1 Scope

This International Standard specifies basic tests to verify the stability of counterbalanced fork-lift trucks. It applies to counterbalanced fork-lift trucks with tiltable or non-tiltable masts, whether rider-controlled or with a separate operator, of rated capacity up to and including 50 000 kg (110 000 lb). It also applies to trucks operating under the same conditions when equipped with load-handling attachments.

This International Standard does not apply to trucks with retractable devices such as a mast or fork, or when handling suspended loads which may swing freely.

NOTE — Additional tests for industrial trucks operating in special conditions of stacking with pre-determined offset will form the subject of a separate International Standard.

2 Normative reference

The following standard contains provisions which, through reference in this text, constitute provisions of this International Standard. At the time of publication, the edition indicated was valid. All standards are subject to revision, and parties to agreements based on this International Standard are encouraged to investigate the possibility of applying the most recent edition of the standard indicated below. Members of IEC and ISO maintain registers of currently valid International Standards.

ISO 5353: 1978, *Earth-moving machinery, and tractors and machinery for agriculture and forestry — Seat index point.*

3 Purpose of tests

3.1 Normal operating conditions

The basic tests specified in this International Standard ensure that such a lift truck demonstrates satisfactory stability when reasonably and appropriately used, under normal operating conditions, i.e.

- a) stacking with the mast approximately vertical and the fork arms reasonably horizontal on substantially firm, smooth, level and prepared surfaces;
- b) travelling with the mast or fork arms tilted rearwards and the load in the lowered (travelling) position on substantially firm, smooth and prepared surfaces;
- c) operating with the load centre of gravity approximately on the longitudinal centre-plane of the truck.

3.2 Operating conditions other than normal

When the operating conditions differ from those stated in 3.1, it is necessary to use either

- a) a truck complying with other International Standard(s) covering the different specific conditions, e.g. ISO 5767¹⁾; or
- b) a truck, the stability of which is agreed upon between the interested parties. This agreed stability shall not be less than that required by the tests specified for normal operating conditions in 3.1.

4 Stability tests for fork-lift trucks

4.1 Test requirements

The stability of these trucks shall be verified by means of one of the procedures described below. For trucks with a rated capacity up to and including 10 000 kg, the tilting platform test shall be used to verify stability in the event of a dispute.

4.2 Verification procedure

4.2.1 Tilting platform

A test platform which can be tilted about one side shall be used. A truck being tested for stability is placed on the initially horizontal test platform, in the conditions specified in 4.3 and, successively, in each of the positions described in table 3.

1) ISO 5767 : 1978, *Industrial trucks operating in special condition of stacking with the mast tilted forward — Stability tests.*

In each of these tests, the test platform shall be tilted slowly to the slope indicated in table 3. The truck is considered stable if it passes all tests without overturning.

For the purposes of these tests, overturning is defined as the test platform slope value which, if increased, would cause overturning of the truck.

It is permissible in lateral tests for one of the load wheels to lose contact with the test platform and it is acceptable for parts of the structure or other designed features to make contact with the test platform.

4.2.2 Fixed slope

Fixed slopes, with inclinations equivalent to the prescribed test slope, shall be used. The slope surface shall be smooth and capable of supporting the truck mass with no deformation likely to affect the test results.

The truck under test shall be driven onto the fixed slopes with mast lowered and positioned according to table 3. For each of the laden truck positions, the load shall be elevated slowly and smoothly to the height indicated in table 3.

4.2.3 Calculation

Compliance with the specified values may be determined by calculation.

Such calculated capacities shall take into account manufacturing variations and deflections of mast, tyres, etc.

4.3 Test conditions

4.3.1 Condition of truck

The tests shall be carried out on an operational truck.

The operator on rider-controlled trucks shall be simulated by an object having a mass of 90 kg if the stability during a test is thereby decreased. For a truck designed for operation with a standing operator, an object having a mass of 90 kg shall be secured with its centre of gravity 1 000 mm above the floor of the operator's platform at the centre of the position normally occupied by the operator. For a truck designed for operation with a seated operator, the centre of gravity of the object shall be secured 150 mm above the seat index point (SIP) as determined in accordance with ISO 5353, with the seat at the mid-point of the adjustments provided.

Fuel tanks of internal combustion engine trucks shall be full if stability is thereby decreased. All other tanks shall be filled to their correct operating levels, as applicable. Tyres shall be inflated to the pressure specified by the truck manufacturer.

4.3.2 Position of truck on platform

For tests Nos. 1 and 2 (see table 3), the truck shall be placed on the test platform so that the load axle is parallel to the tilt axis, XY, of the test platform (see figure 9).

For tests Nos. 3 and 4, the truck shall be placed on the test platform in a turning position with line MN parallel to the tilt axis, XY of the test platform. In figures 10, 11 and 12, the steer wheel nearest to the tilt axis shall be parallel with it.

Lateral stability tests shall be conducted to the side of the truck which is the less stable.

Point N is the centrepoint of the area of contact between the test platform surface and the front wheel nearest the tilting axis (see figures 10, 11 and 12).

Point M is defined as follows:

- a) for trucks having an articulated steering axle: the projection on the test platform of the intersection of the longitudinal centre-plane AB of the truck with the axis of this axle (see figure 10);
- b) for trucks steered by a single swivelling wheel: the centrepoint of the tread contact area between the steer wheel and the test platform surface (see figure 11);
- c) for trucks steered by twin swivelling wheels: the centrepoint of the tread contact area between the steer wheel nearer to the axis of tilt XY, and the test platform surface (see figure 12);
- d) for trucks having steer wheels not connected by a common axle, but which are arranged to articulate approximately about the longitudinal centre-plane of the truck, the projection on the test platform of the intersection of the longitudinal centre-plane of the truck, AB, with a line CD (see figure 10) connecting the vertical turning axes of the steer wheels.

4.3.3 Test load

The test load shall have a mass equivalent to the maximum load, Q , which the truck can elevate to its maximum lift height acting through the centre of gravity, G, nominally positioned at the standard load centre distance, D , as indicated on the information plate of the truck both horizontally from the front face of the fork arm shank and vertically from the upper face of the fork arm blade.

When additional lift heights, loads, and load centre distances are to be indicated on the information plate, the truck shall meet the requirements established by the tests specified in this International Standard for these additional ratings.

The centre of gravity, G, of the test load (see figure 1) shall be located in the longitudinal centre-plane, AB, of the truck (see figures 9, 10, 11 and 12).

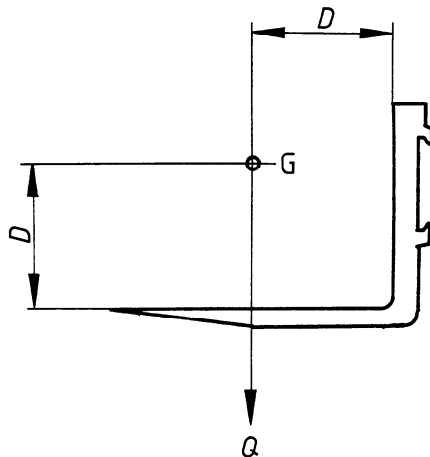

Figure 1

Table 1 – Standard load centre distance

Metric units		Imperial units	
Load Q kg	Load centre distance D mm	Load Q lb	Load centre distance D in
$Q < 1\ 000$	400	$Q < 30\ 000$	24
$1\ 000 < Q < 4\ 999$	500		
$5\ 000 < Q < 10\ 000$	600		
$Q > 10\ 000$	600 or 900 or 1 200 or 1 500	$Q > 30\ 000$	24 or 36 or 48

4.3.4 Location of truck on test platform

The initial position of the truck on the test platform shall be maintained during each test.

This may be achieved by application of parking or service brakes, which can be secured in the "on" position, or by wedging the wheels against the truck frame, ensuring however that articulation is not affected.

Blocks (chocks) having a maximum height not exceeding the value indicated in table 2 may be used, if necessary, to maintain the initial position of the truck on the test platform. Blocks (chocks), if used, shall not artificially improve stability.

Table 2 – Height of blocks

Tyre outside diameter, d mm	Height of blocks (chocks) max.
$d < 250$	25 mm
$d > 250$	0,1 d

The coefficient of friction of the platform surface may be increased if necessary by an appropriate friction-increasing material.

4.3.5 Position of front face of fork arm shank

Test No. 1 shall be conducted with the horizontal position of a load datum point (e.g. point E) unchanged when elevated from its lowered position (see figure 4).

By means of a plumb-line or other suitable equipment, set the mast vertical. Elevate the fork and the prescribed test load to approximately 300 mm (12 in) above the test platform. With the front face of the fork arm shank vertical, establish a point, E, (see figure 2) on the fork or fork carrier having a fixed relationship to the centre of gravity of the test load, G, (see figure 1). This point, E, shall be used to provide a reference datum, F, on the test platform (see figure 2). When the mast is elevated, a new point, F₁, on the test platform may occur (see figure 3): by the following adjustments this new point, F₁, can be returned to the original location of F (see figure 4).

For trucks with tiltable masts, changes in the location of F₁ shall be corrected by varying the tilt of the mast within the limits provided by the design of the truck.

For trucks with fixed masts, adjustments in the fork arms or fork carrier tilt (where provided) may be used to correct for changes in location of point F₁ within the limits of tilt provided by the design of the truck.

For trucks having non-tiltable masts, fork arms, or fork carrier, adjustments cannot be made.

4.3.6 Lift height for tests simulating travel

For tests simulating travel, i.e. tests Nos. 2 and 4, the upper face of the fork arms, measured at the heel of the fork arm, shall be positioned approximately 300 mm (12 in) from the test platform.

4.3.7 Safety precautions

Precautions shall be taken to prevent the overturning of the truck or displacement of the test load during the course of the test. If the means for preventing the total overturning of the truck consist of rope lashing or chain, this shall be sufficiently slack to impose no appreciable restriction on the truck until the overturning point is reached.

Displacement of the test load shall be prevented by means such as:

- a) firmly securing the test load to the load carrier or equivalent structure;
- b) Suspending the test load near the ground from an appropriate support placed on the fork so that the suspension point is at the point where the centre of gravity, G, of the test load would be if the test load were to be placed on the fork.

5 Stability tests for trucks with attachments

Trucks fitted with attachments other than fork arms shall be subjected to the same stability tests, except in cases where the attachment can bring the centre of gravity of the load out of the longitudinal centre-plane, AB, of the truck [see 3.1c)].

For verification of the vertical position of the mast, a reference point having a fixed relationship to the centre of gravity of the test load, G, (see figure 1) shall be chosen.

The test load shall be the specified load, at the specified load centre distance indicated for the attachment when used on the truck being tested.

The fork lift height specified for the tests shall be measured between the test platform surface and the underside of the load or the attachment, whichever is the lower.

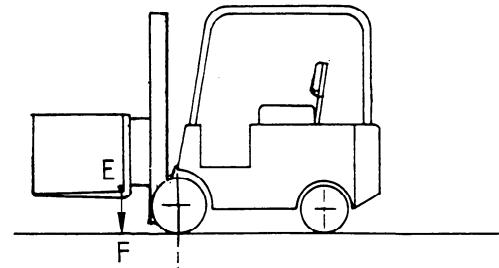

Figure 2

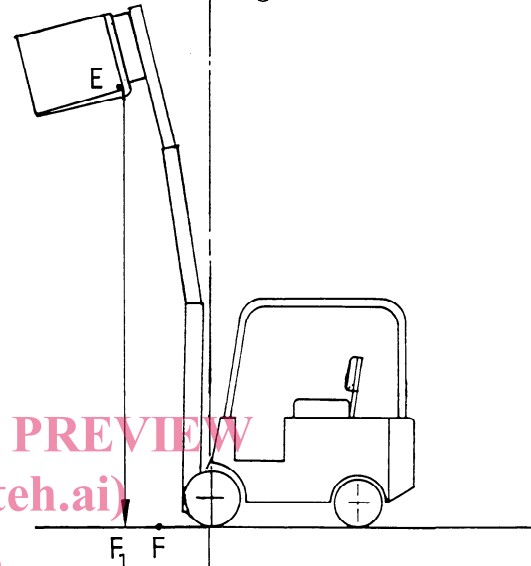

Figure 3

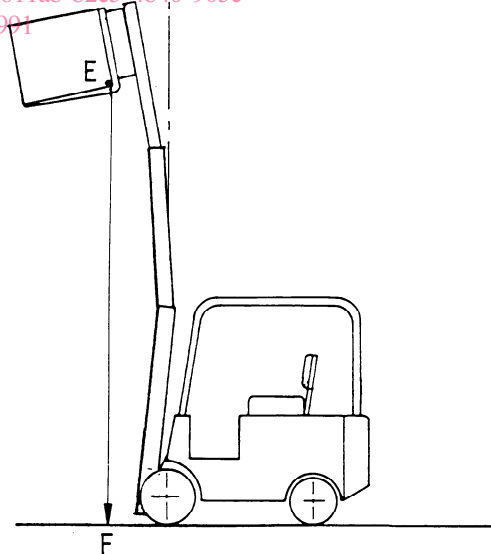
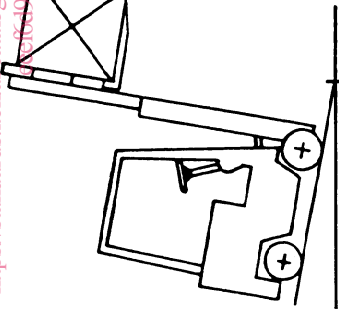
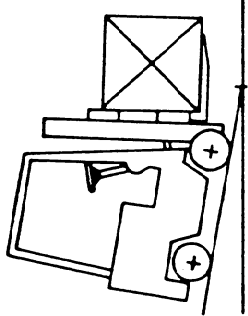
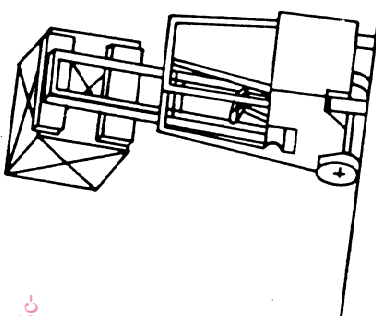
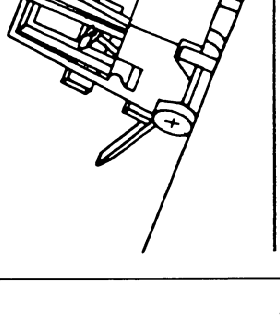
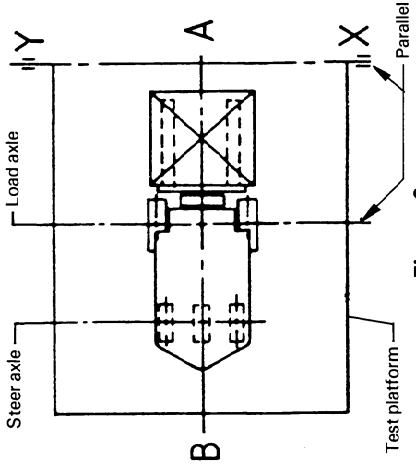
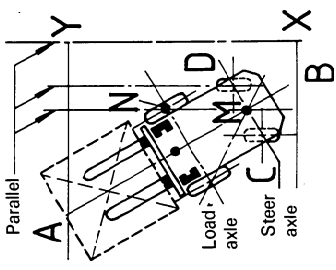
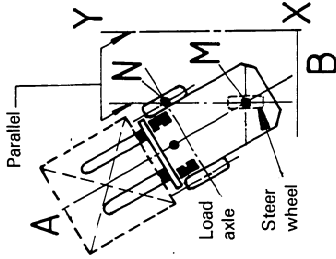
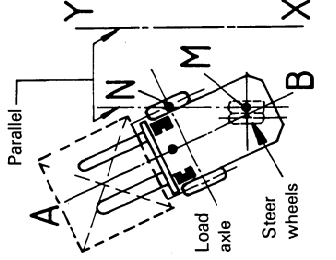

Figure 4

iTeh STANDARD PREVIEW
 (standards.iteh.ai)
<https://standards.iteh.ai/catalog/standards/sist/614611ab-b2e5-4b40-909c-eeef6d95fd18/iso-1074-1991>
 ISO 1074:1991

Table 3 — Summary of tests

Test No.	1		2		3		4		
	Longitudinal		Lateral		Stacking		Travelling		
Stability									
Operation	Stacking		Travelling		Stacking		Travelling		
Load	Test load		Test load		Test load		Unladen		
Lift height	Maximum		Lowered (see 4.3.6)		Maximum		Lowered (see 4.3.6)		
Position of mast	Vertical				Full rearward tilt (for trucks with tiltable mast)				
Position on test platform	Figures 5 and 9		Figures 6 and 9		Figures 7 and 10, 11 or 12		Figures 8 and 10, 11 or 12		
Test platform slope	Rated capacity ≤ 4 999 kg (10 000 lb)		4 %		6 %		(15 + 1,4 v) %* or (15 + 2,25 v ₁) %* (50 % max.)		
	5 000 kg (10 001 lb) ≤ rated capacity ≤ 50 000 kg (110 000 lb)		3,5 %		6 %		(15 + 1,4 v) %* or (15 + 2,25 v ₁) %* (40 % max.)		
Position of truck on test platform	 <p>Figure 5</p>		 <p>Figure 6</p>		 <p>Figure 7</p>		 <p>Figure 8</p>		
	 <p>Figure 9</p>		 <p>Figure 10</p>		 <p>Figure 11</p>		 <p>Figure 12</p>		
	<p>AB: longitudinal centre-plane of truck CD: axis of steer axle MN: truck axis of original tilt XY: axis of tilt of test platform</p>								
		<p>*) v = maximum speed of unladen truck in km/h; v₁ = maximum speed of unladen truck in mile/h.</p>							

iTeh STANDARD PREVIEW
(standards.iteh.ai)

ISO 1074:1991

<https://standards.iteh.ai/catalog/standards/sist/614611ab-b2e5-4b40-905c-eeef6d95fd18/iso-1074-1991>

UDC 621.868.27 : 629.1.073

Descriptors : handling equipment, industrial trucks, lift trucks, tests, stability tests, safety requirements.

Price based on 5 pages
