**Fire protection — Automatic
sprinkler systems —**

**Part 2:
Requirements and test methods for
wet alarm valves, retard chambers
and water motor alarms**

iTeh STANDARD PREVIEW

(standards.iteh.ai) *Protection contre l'incendie — Systèmes d'extinction automatiques du type sprinkler —*

Partie 2: Exigences et méthodes d'essai des soupapes d'alarme hydrauliques, des limiteurs de surpression et des dispositifs d'alarme à moteur hydraulique

<https://standards.iteh.ai/catalog/standards/sist/44190c-76ef-4ec4-ab06-91c6a5d12d3d/iso-6182-2-2012>



iTeh STANDARD PREVIEW
(standards.iteh.ai)

ISO 6182-2:2012

<https://standards.iteh.ai/catalog/standards/sist/f44f190c-70ef-4ac4-abb8-9ff61ba3d18d/iso-6182-2-2012>



COPYRIGHT PROTECTED DOCUMENT

© ISO 2012

All rights reserved. Unless otherwise specified, no part of this publication may be reproduced or utilized in any form or by any means, electronic or mechanical, including photocopying and microfilm, without permission in writing from either ISO at the address below or ISO's member body in the country of the requester.

ISO copyright office
Case postale 56 • CH-1211 Geneva 20
Tel. + 41 22 749 01 11
Fax + 41 22 749 09 47
E-mail copyright@iso.org
Web www.iso.org

Published in Switzerland

Contents

	Page
Foreword	iv
1 Scope	1
2 Normative references	1
3 Terms and definitions	1
4 Requirements	3
4.1 Nominal sizes.....	3
4.2 Connections.....	3
4.3 Rated working pressure.....	3
4.4 Bodies and covers.....	3
4.5 Strength (see 6.9).....	4
4.6 Access for maintenance.....	4
4.7 Components.....	4
4.8 Leakage (see 6.8).....	5
4.9 Non-metallic components (excluding gaskets, seals and other elastomeric parts) (see 6.4 and 6.5).....	5
4.10 Sealing assembly elements (see 6.3).....	5
4.11 Clearances.....	5
4.12 Hydraulic friction loss (see 6.7).....	7
4.13 Endurance (see 6.6).....	8
4.14 Operational performance (see 6.10).....	8
4.15 Drains.....	9
4.16 Alarms (see 6.10.2).....	9
4.17 Retard device (see 6.12).....	9
4.18 Water motor alarms (see 6.11).....	10
5 Production testing and quality control	11
6 Tests	12
6.1 Samples.....	12
6.2 Spring and diaphragm test.....	12
6.3 Sealing element tests (see 4.10).....	12
6.4 Warm water aging test for non-metallic components (excluding gaskets and seals and other elastomeric parts) (see 4.9).....	14
6.5 Air aging test for non-metallic components (excluding gaskets and seals and other elastomeric parts) (see 4.9).....	14
6.6 Endurance test (see 4.13).....	15
6.7 Hydraulic friction loss test (see 4.12).....	15
6.8 Valve leakage and deformation tests (see 4.8).....	15
6.9 Body strength test (see 4.5).....	16
6.10 Operational test (see 4.14).....	16
6.11 Water motor alarm tests (see 4.16).....	17
6.12 Retard chamber tests (see 4.17).....	18
6.13 Salt mist corrosion test.....	18
7 Marking	18
8 Manufacturer's installation instructions	19
Annex A (normative) Tolerances	20

Foreword

ISO (the International Organization for Standardization) is a worldwide federation of national standards bodies (ISO member bodies). The work of preparing International Standards is normally carried out through ISO technical committees. Each member body interested in a subject for which a technical committee has been established has the right to be represented on that committee. International organizations, governmental and non-governmental, in liaison with ISO, also take part in the work. ISO collaborates closely with the International Electrotechnical Commission (IEC) on all matters of electrotechnical standardization.

International Standards are drafted in accordance with the rules given in the ISO/IEC Directives, Part 2.

The main task of technical committees is to prepare International Standards. Draft International Standards adopted by the technical committees are circulated to the member bodies for voting. Publication as an International Standard requires approval by at least 75 % of the member bodies casting a vote.

Attention is drawn to the possibility that some of the elements of this document may be the subject of patent rights. ISO shall not be held responsible for identifying any or all such patent rights.

ISO 6182-2 was prepared by Technical Committee ISO/TC 21, *Equipment for fire protection and fire fighting*, Subcommittee SC 5, *Fixed firefighting systems using water*.

This third edition cancels and replaces the second edition (ISO 6182-2:2005), which has been technically revised.

ISO 6182 consists of the following parts, under the general title *Fire protection — Automatic sprinkler systems*:

- Part 1: Requirements and test methods for sprinklers
- Part 2: Requirements and test methods for wet alarm valves, retard chambers and water motor alarms
- Part 3: Requirements and test methods for dry pipe valves
- Part 4: Requirements and test methods for quick-opening devices
- Part 5: Requirements and test methods for deluge valves
- Part 6: Requirements and test methods for check valves
- Part 7: Requirements and test methods for early suppression fast response (ESFR) sprinklers
- Part 8: Requirements and test methods for pre-action dry alarm valves
- Part 9: Requirements and test methods for water mist nozzles
- Part 10: Requirements and test methods for domestic sprinklers
- Part 11: Requirements and test methods for pipe hangers
- Part 12: Requirements and test methods for grooved-end components for steel pipe systems

Fire protection — Automatic sprinkler systems —

Part 2:

Requirements and test methods for wet alarm valves, retard chambers and water motor alarms

1 Scope

This part of ISO 6182 specifies performance, requirements, methods of test and marking requirements, for wet alarm valves, retard chambers, water motor alarms and manufacturers' specified relevant trim used in wet pipe automatic fire protection systems.

This part of ISO 6182 is not applicable to performance and test requirements for other auxiliary components or attachments to alarm valves.

2 Normative references

The following referenced documents are indispensable for the application of this document. For dated references, only the edition cited applies. For undated references, the latest edition of the referenced document (including any amendments) applies.

ISO 898-1, *Mechanical properties of fasteners made of carbon steel and alloy steel — Part 1: Bolts, screws and studs with specified property classes — Coarse thread and fine pitch thread*

ISO 898-2, *Mechanical properties of fasteners made of carbon steel and alloy steel — Part 2: Nuts with specified property classes — Coarse thread and fine pitch thread*

3 Terms and definitions

For the purposes of this document, the following terms and definitions apply.

3.1

alarm device

mechanical or electrical device which sounds an alarm upon operation of the valve

3.2

clapper

type of sealing assembly

NOTE See also 3.13.

3.3

compensator

external or internal device such as an auxiliary valve that minimizes false alarms caused by a small increase of service pressure

3.4

corrosion-resistant material

bronze, brass, Monel metal, austenitic stainless steel, or equivalent metallic or plastic material conforming with the requirements of this part of ISO 6182

NOTE Monel is an example of a suitable product available commercially. This information is given for the convenience of users of this part of ISO 6182 and does not constitute an endorsement by ISO of this product.

3.5

flow velocity

speed of water flow through a valve expressed as the equivalent water velocity through a pipe of the same nominal size as the valve

3.6

minimum opening pressure

the minimum pressure when water begins to pass through the valve

3.7

rated working pressure

maximum service pressure at which a valve or retard chamber is intended to operate

3.8

ready (set) condition

state of a valve with the sealing assembly in the closed or set position with service and system pressure applied

3.9

reinforced elastomeric element

element of clapper, clapper assembly or seat seals in a composite of an elastomeric compound with one or more other components

3.10

retard chamber

volumetric type of retard device designed to minimize false alarms caused by surges and fluctuations in sprinkler system water supplies

3.11

retard device

pneumatic, hydraulic or electric timer designed to minimize false alarms caused by surges and fluctuations in sprinkler system water supplies

3.12

retard time

difference in time for actuation of alarm devices, measured from the passage of water through the wet alarm valve port, with and without the retard chamber

3.13

sealing assembly

main movable sealing element (such as a clapper) of the valve which prevents the reverse flow of water

3.14

sealing assembly seat ring

main fixed sealing element of a valve which prevents the reverse flow of water

3.15

sensitivity

minimum rate of flow from a system outlet which will open the wet alarm valve, as indicated by satisfactory operation of alarms

3.16

service pressure

static water pressure at the inlet to a valve when the valve is in the ready condition

3.17

system pressure

static water pressure at the main outlet of a valve when the valve is in the ready condition

3.18**trim**

external equipment and pipework, excluding the main installation pipework, fitted to the valve

3.19**waste of water**

discharge of any water from the alarm port of a valve that is in the ready condition

3.20**water motor alarm**

hydraulically actuated device which provides a local audible alarm as a result of a flow through an alarm valve

3.21**wet alarm valve**

valve that permits flow of water into a wet sprinkler system, prevents the reverse flow of water and incorporates provision for actuation of an alarm under specified flow conditions

3.22**wet pipe system**

automatic fire protection system in which the piping contains water and is connected to a water supply so that water discharges upon operation of the sprinklers

4 Requirements**4.1 Nominal sizes**

The nominal size of a valve shall be the nominal diameter of the inlet and outlet connections, i.e. the pipe size for which the connections are intended. Sizes shall be 40 mm, 50 mm, 65 mm, 80 mm, 100 mm, 125 mm, 150 mm, 200 mm or 250 mm. The diameter of the waterway through the sealing assembly seat ring shall be permitted to be less than the nominal size.

4.2 Connections

4.2.1 All connections shall be designed for use at the rated working pressure of the valve.

4.2.2 The dimensions of all connections shall conform with the applicable requirements of International Standards. If International Standards are not applicable, National standards shall be permitted to be used.

4.2.3 An opening not smaller than 15 mm nominal diameter shall be provided for a water motor alarm line connection.

4.3 Rated working pressure

4.3.1 The rated working pressure shall be not less than 1,2 MPa (12 bar).

4.3.2 Inlet and outlet connections shall be permitted to be machined for lower working pressures to match installation equipment provided the valve is marked with the lower working pressure. See 7.3 f).

4.4 Bodies and covers

4.4.1 The body and cover shall be made of a material having corrosion resistance at least equivalent to cast iron.

4.4.2 Cover fasteners shall be made of steel, stainless steel, titanium, or other materials with equivalent physical and mechanical properties.

4.4.3 Non-metallic materials other than gaskets, diaphragms and seals or metals with a melting point less than 800 °C shall not form part of the valve body or cover.

4.4.4 It shall not be possible to assemble the valve with the cover plate in a position which either improperly indicates flow direction or prevents proper operation of the valve.

4.5 Strength (see 6.9)

4.5.1 An assembled valve, with the sealing assembly blocked open, shall withstand, without rupture, an internal hydrostatic pressure of four times the rated working pressure for a period of 5 min, when tested as specified in 6.9.

4.5.2 If the test in accordance with 6.9 is not done with standard production fasteners, the supplier shall provide documentation showing that the calculated design load of any standard production fastener, neglecting the force required to compress the gasket, does not exceed the minimum tensile strength specified in ISO 898-1 and ISO 898-2 when the valve is pressurized to four times the rated working pressure. The area of the application of pressure shall be calculated as follows.

- a) If a full-face gasket is used, the area of application of pressure is that extending out to a line defined by the inner edge of the bolts.
- b) If an "O"-ring seal or ring gasket is used, the area of application of force is that extending out to the centre line of the "O"-ring or gasket.

ITeH STANDARD PREVIEW
(standards.iteh.ai)

4.6 Access for maintenance

ISO 6182-2:2012

<https://standards.iteh.ai/catalog/standards/sist/f44f190c-70ef-4ac4-abb8-961610101010>

Means shall be provided to permit access to working parts and removal of the sealing assembly. Any method adopted shall permit ready maintenance by one person with a minimum of down time.

4.7 Components

4.7.1 Any component which is normally disassembled during servicing shall be designed so that it cannot be reassembled improperly without providing an external visual indication, when the valve is returned to service.

4.7.2 With the exception of valve seats, all parts intended for field replacement shall be capable of being disassembled and reassembled using tools normally employed by the trade.

4.7.3 All components shall be non-detachable during normal operation of the valve.

4.7.4 Failure of the sealing assembly diaphragms or seals shall not prevent the valve from opening.

4.7.5 Sealing surfaces of sealing assemblies, including the sealing assembly seat ring, shall have corrosion resistance equivalent to brass or bronze and have sufficient width of surface contact to withstand ordinary wear and tear, rough usage, compression stresses and damage due to pipe scale or foreign matter carried by the water.

4.7.6 Springs and diaphragms shall not fracture or rupture, when tested in accordance with 6.2.

4.7.7 There shall be no sign, on visual examination, of damage to the sealing assembly after testing for the operational requirements of 4.14 in accordance with 6.10.

4.7.8 When wide open, the sealing assembly shall bear against a definite stop. The point of contact shall be located so that impact or reaction of the water flow will not permanently twist, bend or fracture valve parts.

4.7.9 Where rotation or sliding motion is required, the part or its bearing shall be made of a corrosion resistant material. Materials lacking corrosion resistance shall be fitted with bushings, inserts or other parts made of corrosion resistant materials at those points where freedom of movement is required.

4.7.10 The sealing assembly shall close towards the seat when water flow ceases. Springs shall be permitted to ensure full and proper seating.

4.8 Leakage (see 6.8)

4.8.1 There shall be no leakage, permanent distortion or rupture of a valve when an internal pressure of twice the rated working pressure is applied for 5 min with the sealing assembly open in accordance with 6.8.1.

4.8.2 There shall be no leakage, permanent distortion or rupture of a valve at an internal pressure of twice the rated working pressure applied to the downstream side of the sealing assembly for 5 min with the upstream end vented in accordance with 6.8.2.1.

4.8.3 A valve shall not leak while being subjected to an internal hydrostatic pressure equivalent to a column of water 1,5 m high for 16 h in accordance with 6.8.2.2.

4.8.4 Sealing surfaces shall prevent leakage of water into the alarm port when the valve is tested in the ready position in accordance with 6.10.

4.9 Non-metallic components (excluding gaskets, seals and other elastomeric parts) (see 6.4 and 6.5)

Non-metallic valve parts that may affect proper valve function as defined in this part of ISO 6182 shall be subjected to the applicable ageing of its non-metallic parts, as described in 6.4 and 6.5, using separate sets of samples, as applicable. After aging, a valve shall meet the requirements of 4.8, 4.13 and 4.14.4 when tested in accordance with the applicable tests described in 6.6, 6.8 and 6.10.

4.10 Sealing assembly elements (see 6.3)

A seal made of elastomeric or other resilient materials shall not adhere to the mating surface when tested in accordance with 6.3.1. Where the same design of seat is used for more than one size of valve, it shall be permitted to only test the size with the highest stress on the seating surface.

4.11 Clearances

The requirements in Clause 4.11 are applicable to hinged, clapper-type valves only.

4.11.1 The radial clearance between a hinged sealing assembly and the inside walls in every position, except wide open, shall not be less than 12 mm for cast iron bodies and shall not be less than 6 mm if the body and sealing assembly are of cast iron or steel with corrosion protective coatings tested in accordance with 6.13, non-ferrous material, stainless steel or materials having equivalent physical, mechanical and corrosion resistant properties. See Figure 1 a).

4.11.2 There shall be a diametrical clearance of not less than 3 mm between the inner edges of a seat ring and the metal parts of a hinged sealing assembly when the valve is in the closed position. See Figure 1 b).

4.11.3 Any space in which the sealing assembly can trap debris beyond the seat shall be not less than 3 mm deep.

4.11.4 The diametrical clearance between hinge pins and their bearings shall be not less than 0,125 mm.

4.11.5 The total axial clearance between the clapper hinge and adjacent valve body bearing surfaces shall be not less than 0,25 mm. See Figure 1 c) or Figure 1 d).

4.11.6 Any reciprocating guide components, which are essential to allow a valve to open, shall have a minimum diametrical clearance of not less than 0,7 mm in that portion over which the moving component enters the fixed component and of not less than 0,05 mm in that portion of the moving component continuously in contact with the fixed component in the ready (set) position.

4.11.7 Sealing assembly guide bushings or hinge-pin bearings shall project a sufficient axial distance to maintain not less than 1,5 mm (Bushing Projection) clearance between ferrous metal parts. See Figure 1. Clearance less than 1,5 mm shall be permitted where adjacent parts are of bronze, brass, Monel metal, austenitic stainless steel, titanium, or similar corrosion resistant materials. When corrosion resistance of steel parts is provided by a protective coating, the parts shall show no visible signs of deterioration of the coating such as blistering, delamination, flaking or increased resistance to movement when tested in accordance with 6.13.

4.11.8 If provided, a compensator shall be designed such that deposits or sediment will not readily accumulate to an extent sufficient to interfere with its proper operation. There shall be sufficient clearances between the working parts to allow proper sealing of the main and any auxiliary valves.

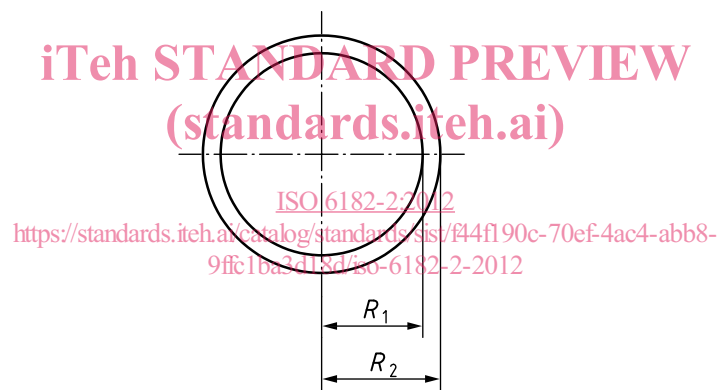

a) Radial clearance, $C_R = R_2 - R_1$

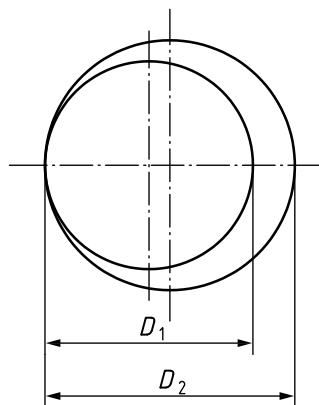

b) Diametrical clearance, $C_D = D_2 - D_1$

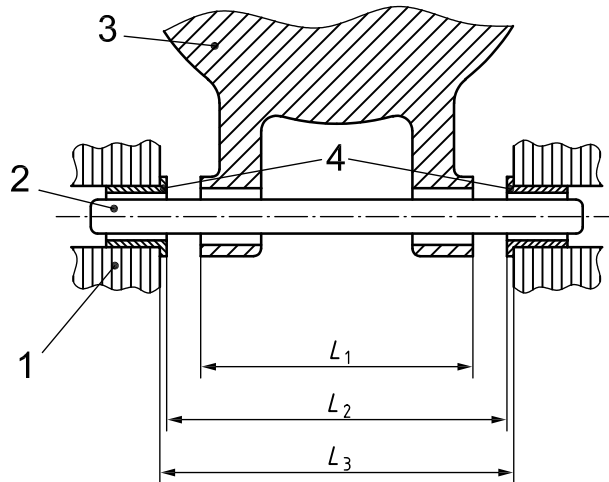

c) Total axial clearance, C_{TA} ; $C_{TA} = L_2 - L_1$; Bushing Projection = $(L_3 - L_2)/2$

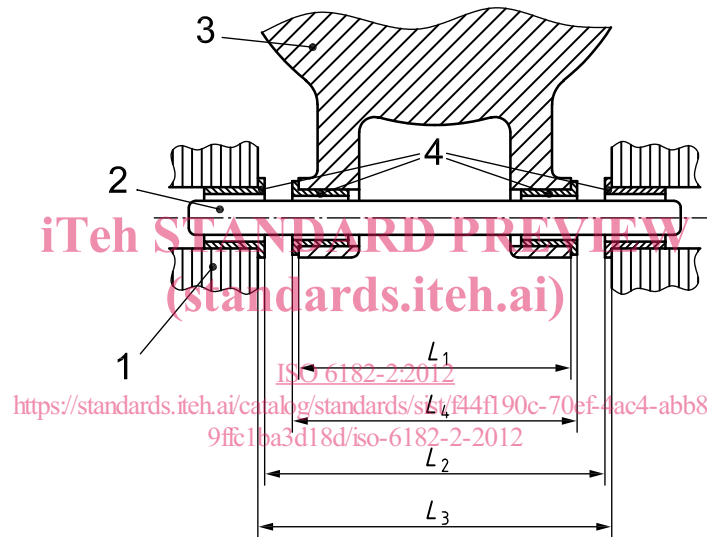

d) Total axial clearance, C_{TA} ($C_{TA} = L_2 - L_4$); Bushing projection = $(L_3 - L_2)/2 + (L_4 - L_1)/2$

Key

- 1 valve body
- 2 pin
- 3 sealing assembly
- 4 bushings

Figure 1 — Types of clearances

4.12 Hydraulic friction loss (see 6.7)

The pressure loss across the valve at the appropriate flow given in Table 1, when tested by the method of 6.7 shall not exceed the pressure loss published in the manufacturer’s installation instructions. See 8.1.

Table 1 — Required flow rates for pressure drop determination

Nominal valve size mm	Flow rate l/min
40	380