



SLOVENSKI STANDARD
SIST ISO 7794:2012

01-marec-2012

Nadomešča:
SIST ISO 7794:1995

Tekaške smuči - Vijaki za varnostne vezi - Zahteve

Cross-country skis -- Ski-binding screws -- Requirements

iTeh STANDARD PREVIEW
Skis de fond -- Vis de fixation -- Exigences
(standards.iteh.ai)

Ta slovenski standard je istoveten z: ~~SIST ISO 7794:2011~~ ISO 7794:2011

<https://standards.iteh.ai/catalog/standards/sist/2d384560-da70-4694-84ab-250b3e3180b/sist-iso-7794-2012>

ICS:

97.220.20 Oprema za zimske športe Winter sports equipment

SIST ISO 7794:2012

en

iTeh STANDARD PREVIEW
(standards.iteh.ai)

SIST ISO 7794:2012

<https://standards.iteh.ai/catalog/standards/sist/2d384560-da70-4694-84ab-250b3c31f30b/sist-iso-7794-2012>

INTERNATIONAL STANDARD

ISO 7794

Third edition
2011-05-15

Cross-country skis — Ski-binding screws — Requirements

Skis de fond — Vis de fixation — Exigences

iTeh STANDARD PREVIEW
(standards.iteh.ai)

[SIST ISO 7794:2012](https://standards.iteh.ai/catalog/standards/sist/2d384560-da70-4694-84ab-250b3c31f30b/sist-iso-7794-2012)

<https://standards.iteh.ai/catalog/standards/sist/2d384560-da70-4694-84ab-250b3c31f30b/sist-iso-7794-2012>



Reference number
ISO 7794:2011(E)

© ISO 2011

iTeh STANDARD PREVIEW (standards.iteh.ai)

SIST ISO 7794:2012

<https://standards.iteh.ai/catalog/standards/sist/2d384560-da70-4694-84ab-250b3c31f30b/sist-iso-7794-2012>



COPYRIGHT PROTECTED DOCUMENT

© ISO 2011

All rights reserved. Unless otherwise specified, no part of this publication may be reproduced or utilized in any form or by any means, electronic or mechanical, including photocopying and microfilm, without permission in writing from either ISO at the address below or ISO's member body in the country of the requester.

ISO copyright office
Case postale 56 • CH-1211 Geneva 20
Tel. + 41 22 749 01 11
Fax + 41 22 749 09 47
E-mail copyright@iso.org
Web www.iso.org

Published in Switzerland

Foreword

ISO (the International Organization for Standardization) is a worldwide federation of national standards bodies (ISO member bodies). The work of preparing International Standards is normally carried out through ISO technical committees. Each member body interested in a subject for which a technical committee has been established has the right to be represented on that committee. International organizations, governmental and non-governmental, in liaison with ISO, also take part in the work. ISO collaborates closely with the International Electrotechnical Commission (IEC) on all matters of electrotechnical standardization.

International Standards are drafted in accordance with the rules given in the ISO/IEC Directives, Part 2.

The main task of technical committees is to prepare International Standards. Draft International Standards adopted by the technical committees are circulated to the member bodies for voting. Publication as an International Standard requires approval by at least 75 % of the member bodies casting a vote.

Attention is drawn to the possibility that some of the elements of this document may be the subject of patent rights. ISO shall not be held responsible for identifying any or all such patent rights.

ISO 7794 was prepared by Technical Committee ISO/TC 83, *Sports and recreational equipment*, Subcommittee SC 4, *Snowsports equipment*.

This third edition cancels and replaces the second edition (ISO 7794:1991), which has been technically revised.

iTeh STANDARD PREVIEW
(standards.iteh.ai)

SIST ISO 7794:2012
<https://standards.iteh.ai/catalog/standards/sist/2d384560-da70-4694-84ab-250b3c31f30b/sist-iso-7794-2012>

Introduction

The use of ski-binding screws that comply with the requirements of this International Standard will improve binding mounting. By standardizing the drill hole diameter, recommendations by the manufacturers will no longer be required, while mistakes and improper mounting, caused by differences in instructions, will be avoided. Standardization of the penetration depth will enable ski manufacturers to design their products so that there will be sufficient thickness in the mounting area and suitable positioning of reinforced parts to make optimum use of the fastening characteristics.

The proposed values for driving torque and stripping torque will enable adjustable torque-limiting screwdrivers to be used with the same adjustment for all skis.

The use of the cross-recess type Z No. 3 screw will also contribute significantly to simplifying the binding mounting procedure.

iTeh STANDARD PREVIEW (standards.iteh.ai)

[SIST ISO 7794:2012](https://standards.iteh.ai/catalog/standards/sist/2d384560-da70-4694-84ab-250b3c31f30b/sist-iso-7794-2012)

<https://standards.iteh.ai/catalog/standards/sist/2d384560-da70-4694-84ab-250b3c31f30b/sist-iso-7794-2012>

Cross-country skis — Ski-binding screws — Requirements

1 Scope

This International Standard specifies the dimensions, mechanical properties, mounting and fastening characteristics of screws used for mounting ski bindings on cross-country skis.

The purpose of this International Standard is to facilitate the design of a more rational and safer binding mounting system.

2 Normative references

The following referenced documents are indispensable for the application of this document. For dated references, only the edition cited applies. For undated references, the latest edition of the referenced document (including any amendments) applies.

ISO 1478, *Tapping screws thread*

ISO 2702, *Heat-treated steel tapping screws — Mechanical properties*

ISO 7795, *Cross-country skis — Ski-binding screws — Test methods*

<https://standards.iteh.ai/catalog/standards/sist/2d384560-da70-4694-84ab-250b3c31f30b/sist-iso-7794-2012>

3 Terms and definitions

For the purposes of this document, the following terms and definitions apply.

3.1

ski-binding screw

fastener which, after mounting, ensures the connection of binding and ski by axial pre-tension

3.2

penetration depth

distance from the top surface of the ski to the lower extremity of the ski-binding screw

3.3

driving torque

maximum value of the moment required to drive the ski-binding screw into the drill hole of the test specimen without lubrication or tapping

3.4

tightening torque

moment, specified in the mounting instructions or in the test procedure, which is used to tighten the ski-binding screw to ensure sufficient fastening

3.5

stripping torque

maximum measurable moment which causes damage to the internal thread in the test assembly, or to the thread of the screw if the already tightened screw is further loaded by a driving moment

ISO 7794:2011(E)**3.6****static pull-out resistance**

resistance of the test assembly to a pull-out force applied to one screw quasistatically in the axial direction

4 Designation

Cross-country ski-binding screws in accordance with this International Standard shall be designated by:

- a) the words “cross-country ski-binding screws”, and the abbreviation “XCSBS”;
- b) the reference of this International Standard, i.e. ISO 7794;
- c) their nominal dimensions, i.e. diameter × length;
- d) the type of screw head.

EXAMPLE Cross-country ski-binding screws of nominal diameter 6,0 mm and length 17 mm, with countersunk heads would be designated:

Cross-country ski-binding screws XCSBS ISO 7794 – 6,0 × 17 with countersunk heads

5 Requirements**5.1 General**

The strength requirements and typical application characteristics of cross-country ski-binding screws are tested in accordance with ISO 7795.

[SIST ISO 7794:2012](https://standards.iteh.ai/catalog/standards/sist/2d384560-da70-4694-84ab-250b3c31f30b/sist-iso-7794-2012)

<https://standards.iteh.ai/catalog/standards/sist/2d384560-da70-4694-84ab-250b3c31f30b/sist-iso-7794-2012>

5.2 Materials

Cross-country ski-binding screws shall be made of steel as specified in ISO 2702, which shall comply with the additional requirements in 5.4 and 5.5 of this International Standard.

5.3 Dimensions**5.3.1 Screw head**

Cross-country ski-binding screws shall be cross recess type Z No. 3 with a recommended minimum penetration depth of 2,72 mm to 3,18 mm (see ISO 4757).

If screws having countersunk heads are used, the angle of countersinking $90^{\circ} \begin{smallmatrix} +2^{\circ} \\ 0 \end{smallmatrix}$ is recommended.

5.3.2 Thread and tip configuration

The cross-section of the screw may be circular or non circular within the major diameter of $6,3 \text{ mm} \begin{smallmatrix} 0 \\ -0,15 \end{smallmatrix}$ mm (see Figure 1).

The tolerance shall be in accordance with Figure 1.

The thread should be extended up to the screw head but shall be at least 1 mm longer than the penetration depth.

The shaft end shall correspond to Figure 1.

Dimensions in millimetres

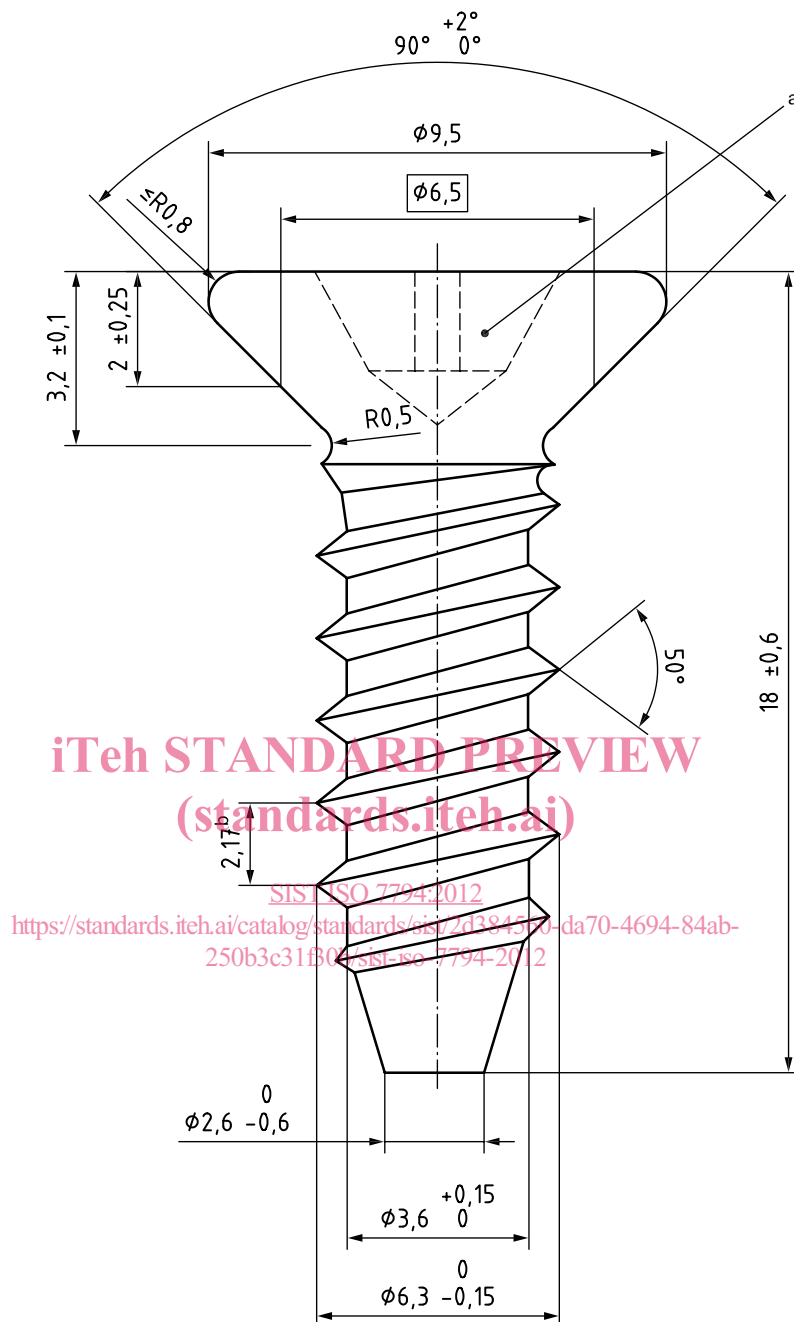

- a Cross-recess type Z No. 3 in accordance with ISO 4757.
 b Pitch.

Figure 1 — Thread and end configuration