



SLOVENSKI STANDARD
oSIST ISO 7795:2011
01-december-2011

Tekaške smuči - Vijaki za varnostne vezi - Preskusne metode

Cross-country skis -- Ski-binding screws -- Test methods

Skis de fond -- Vis de fixation -- Méthodes d'essai

Ta slovenski standard je istoveten z: ISO 7795:2011

ICS:

97.220.20 Oprema za zimske športe Winter sports equipment

oSIST ISO 7795:2011

en

INTERNATIONAL STANDARD

**ISO
7795**

Third edition
2011-08-01

Cross-country skis — Ski-binding screws — Test methods

Skis de fond — Vis de fixation — Méthodes d'essai



Reference number
ISO 7795:2011(E)

© ISO 2011



COPYRIGHT PROTECTED DOCUMENT

© ISO 2011

All rights reserved. Unless otherwise specified, no part of this publication may be reproduced or utilized in any form or by any means, electronic or mechanical, including photocopying and microfilm, without permission in writing from either ISO at the address below or ISO's member body in the country of the requester.

ISO copyright office
Case postale 56 • CH-1211 Geneva 20
Tel. + 41 22 749 01 11
Fax + 41 22 749 09 47
E-mail copyright@iso.org
Web www.iso.org

Published in Switzerland

Foreword

ISO (the International Organization for Standardization) is a worldwide federation of national standards bodies (ISO member bodies). The work of preparing International Standards is normally carried out through ISO technical committees. Each member body interested in a subject for which a technical committee has been established has the right to be represented on that committee. International organizations, governmental and non-governmental, in liaison with ISO, also take part in the work. ISO collaborates closely with the International Electrotechnical Commission (IEC) on all matters of electrotechnical standardization.

International Standards are drafted in accordance with the rules given in the ISO/IEC Directives, Part 2.

The main task of technical committees is to prepare International Standards. Draft International Standards adopted by the technical committees are circulated to the member bodies for voting. Publication as an International Standard requires approval by at least 75 % of the member bodies casting a vote.

Attention is drawn to the possibility that some of the elements of this document may be the subject of patent rights. ISO shall not be held responsible for identifying any or all such patent rights.

ISO 7795 was prepared by Technical Committee ISO/TC 83, *Sports and recreational equipment*, Subcommittee SC 4, *Snowsports equipment*.

This third edition cancels and replaces the second edition (ISO 7795:1994), which has been technically revised.

Cross-country skis — Ski-binding screws — Test methods

1 Scope

This International Standard specifies test methods for determining the mounting and fastening characteristics of screws that are intended for fastening ski binding to cross-country skis. The requirements for ski-binding screws are specified in ISO 7794.

The results of the test methods specified in this International Standard characterize only the properties of the screw. The results do not specify the actual mounting and fastening characteristics of different ski models, this information being specified in ISO 9119.

2 Normative references

The following referenced documents are indispensable for the application of this document. For dated references, only the edition cited applies. For undated references, the latest edition of the referenced document (including any amendments) applies.

ISO 6506-1, *Metallic materials — Brinell hardness test — Part 1: Test method*

ISO 7794, *Cross-country skis — Ski binding screws — Requirements*

3 Terms and definitions

For the purposes of this document, the terms and definitions given in ISO 7794 apply.

4 Apparatus

4.1 Test assembly

The tests shall be performed on five test assemblies representative of material configurations, and with dimensions similar to those of a cross-section of the binding mounting area of a cross-country ski of a commonly used brand mark.

4.2 Drill and test jig

A jig, as shown in Figure 1, shall be used for drilling the holes and also for determining the driving torque and the stripping torque.

Used with a removable drill bushing, the jig shall ensure an exact drill hole of diameter $3,6\left(\begin{smallmatrix} +0,15 \\ 0 \end{smallmatrix}\right)$ mm, perpendicular to the top surface of the test assembly.

The jig shall also ensure that the screw is set and mounted perpendicular to the top surface of the test assembly.

Dimensions in millimetres

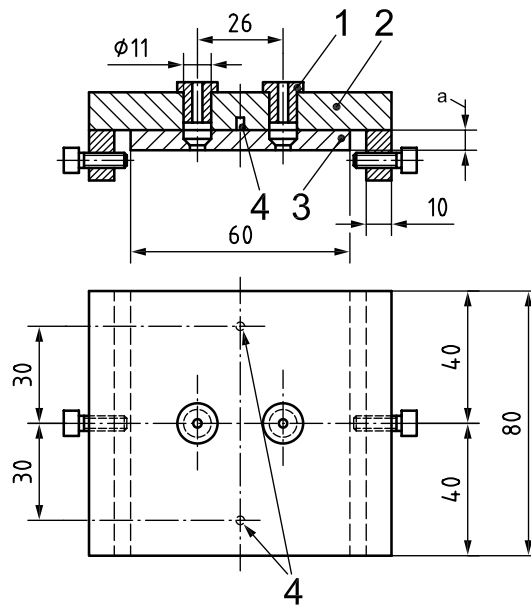

Key

- 1 drill jig bushing
 - 2 drill jig
 - 3 friction plate
 - 4 centering pin to locate the friction plate
- a Thickness according to the penetration depth needed.

Figure 1 — Drill and test jig

The jig shall be equipped with a friction plate (see Figure 2), provided with conical or straight holes, depending on the type of screw head. It shall be made of steel with a Brinell surface hardness of 135 HBW 1/30/20, in accordance with ISO 6506-1.

The countersink of the friction plate shall be machined with a precision tool, in order to ensure correct dimensions. The surface roughness shall be such that no vibration marks are visible.

Dimensions in millimetres

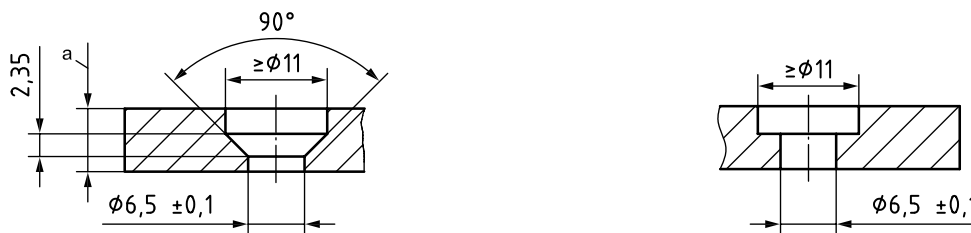

a) For screws with countersunk head

b) For screws with flat head

- a Thickness according to the penetration depth needed.

Figure 2 — Friction plate