

---

---

**Cross-country skis — Binding mounting  
area — Requirements for test screws**

*Skis de fond — Zone de montage de la fixation — Exigences pour les  
vis d'essai*

**iTeh STANDARD PREVIEW**  
**(standards.iteh.ai)**

[ISO 10228:2011](https://standards.iteh.ai/catalog/standards/sist/c4e6270d-ae99-46b6-b97e-b9134fb60b37/iso-10228-2011)

[https://standards.iteh.ai/catalog/standards/sist/c4e6270d-ae99-46b6-b97e-  
b9134fb60b37/iso-10228-2011](https://standards.iteh.ai/catalog/standards/sist/c4e6270d-ae99-46b6-b97e-b9134fb60b37/iso-10228-2011)



**iTeh STANDARD PREVIEW**  
**(standards.iteh.ai)**

ISO 10228:2011

<https://standards.iteh.ai/catalog/standards/sist/c4e6270d-ae99-46b6-b97e-b9134fb60b37/iso-10228-2011>



**COPYRIGHT PROTECTED DOCUMENT**

© ISO 2011

All rights reserved. Unless otherwise specified, no part of this publication may be reproduced or utilized in any form or by any means, electronic or mechanical, including photocopying and microfilm, without permission in writing from either ISO at the address below or ISO's member body in the country of the requester.

ISO copyright office  
Case postale 56 • CH-1211 Geneva 20  
Tel. + 41 22 749 01 11  
Fax + 41 22 749 09 47  
E-mail [copyright@iso.org](mailto:copyright@iso.org)  
Web [www.iso.org](http://www.iso.org)

Published in Switzerland

## Foreword

ISO (the International Organization for Standardization) is a worldwide federation of national standards bodies (ISO member bodies). The work of preparing International Standards is normally carried out through ISO technical committees. Each member body interested in a subject for which a technical committee has been established has the right to be represented on that committee. International organizations, governmental and non-governmental, in liaison with ISO, also take part in the work. ISO collaborates closely with the International Electrotechnical Commission (IEC) on all matters of electrotechnical standardization.

International Standards are drafted in accordance with the rules given in the ISO/IEC Directives, Part 2.

The main task of technical committees is to prepare International Standards. Draft International Standards adopted by the technical committees are circulated to the member bodies for voting. Publication as an International Standard requires approval by at least 75 % of the member bodies casting a vote.

Attention is drawn to the possibility that some of the elements of this document may be the subject of patent rights. ISO shall not be held responsible for identifying any or all such patent rights.

ISO 10228 was prepared by Technical Committee ISO/TC 83, *Sports and recreational equipment*, Subcommittee SC 4, *Snowsports equipment*.

This second edition cancels and replaces the first edition (ISO 10228:1991), which has been technically revised.

**iTeh STANDARD PREVIEW**  
**(standards.iteh.ai)**  
ISO 10228:2011  
<https://standards.iteh.ai/catalog/standards/sist/c4e6270d-ae99-46b6-b97e-b9134fb60b37/iso-10228-2011>

## Introduction

The use of test screws ensures the comparability of measurement data, which are determined by the manufacturer or other institutions by testing the binding mounting area of cross-country skis.

# iTeh STANDARD PREVIEW (standards.iteh.ai)

[ISO 10228:2011](https://standards.iteh.ai/catalog/standards/sist/c4e6270d-ae99-46b6-b97e-b9134fb60b37/iso-10228-2011)

<https://standards.iteh.ai/catalog/standards/sist/c4e6270d-ae99-46b6-b97e-b9134fb60b37/iso-10228-2011>

# Cross-country skis — Binding mounting area — Requirements for test screws

## 1 Scope

This International Standard specifies the dimensions, mechanical properties and fastening characteristics of test screws used for testing the binding mounting area of cross-country skis.

## 2 Normative references

The following referenced documents are indispensable for the application of this document. For dated references, only the edition cited applies. For undated references, the latest edition of the referenced document (including any amendments) applies.

ISO 1478, *Tapping screws thread*

ISO 2702, *Heat-treated steel tapping screws — Mechanical properties*

ISO 7794, *Cross-country skis — Ski-binding screws — Requirements*

ISO 7795, *Cross-country skis — Ski-binding screws — Test methods*

## 3 Terms and definitions

For the purposes of this document, the definitions given in ISO 7794 and the following apply.

### 3.1

#### **test screw**

fastener, which is used for testing the binding mounting area to ensure the comparability of measurement data

## 4 Designation

Test screws in accordance with this International Standard shall be designated by:

- the words “Test screw”;
- the reference to this International Standard, i.e. ISO 10228;
- their nominal dimensions, i.e. diameter × length.

EXAMPLE Test screws with a nominal diameter of 6,3 mm and a length of 18 mm would be designated:

**Test screw ISO 10228 — 6,3 × 18**

## 5 Requirements

### 5.1 General

The strength requirements and typical application characteristics of cross-country ski-binding test screws shall be tested in accordance with ISO 7795.

### 5.2 Materials

Test screws shall be made of steel as specified in ISO 2702, which shall comply with the additional requirements in 5.4 and 5.5 of this International Standard.

### 5.3 Dimensions

#### 5.3.1 Screw head

Test screws shall be cross recess type Z No. 3 with a recommended minimum penetration depth of 2,72 mm to 3,18 mm (see ISO 4757).

If screws having countersunk heads are used, the angle of countersinking  $90^{\circ} \begin{smallmatrix} +2^{\circ} \\ -0^{\circ} \end{smallmatrix}$  is recommended.

#### 5.3.2 Thread and end configuration

The cross-section of the test screw may be circular or non-circular within the major diameter of  $6,3 \text{ mm} \begin{smallmatrix} 0 \\ -0,15 \end{smallmatrix}$  mm (see Figure 1).

The thread length shall be at least 1 mm longer than the penetration depth, irrespective of the shaft length. The tolerance on the length of the screw shall be  $\pm 0,6 \text{ mm}$ .

The shaft end shall correspond to Figure 1.

### 5.4 Surface

Test screws shall be coated or plated with materials which provide adequate protection against corrosion and ensure a reproducible coefficient of friction.

For example, a suitable coating would be a zinc electroplated coating, Fe/Zn 5c (see ISO 4042), having a clear chromate conversion coating and a minimum local thickness of 5  $\mu\text{m}$  (batch average 4  $\mu\text{m}$  min., 6  $\mu\text{m}$  max.), when measured on the top surface of the screw head.

During electroplating, adequate precautions shall be taken to avoid hydrogen embrittlement.

### 5.5 Application characteristics

#### 5.5.1 General

The specified fastening and mounting characteristics of the test screw shall be based on a uniform drill diameter of  $3,6 \text{ mm} \begin{smallmatrix} +0,15 \\ 0 \end{smallmatrix}$  mm.

#### 5.5.2 Strength requirements

The breaking moment for test screws under a torque of the same axis and direction as the driving torque shall be not less than 10 N·m.

The screws shall not break when subjected to the conditions of the ductility test.

### 5.5.3 Fastening characteristics

The mean static pull-out resistance shall correspond to at least that of a reference screw complying with the requirements of ISO 1478, type F, and having a nominal diameter of 6,3 mm.

Dimensions in millimetres

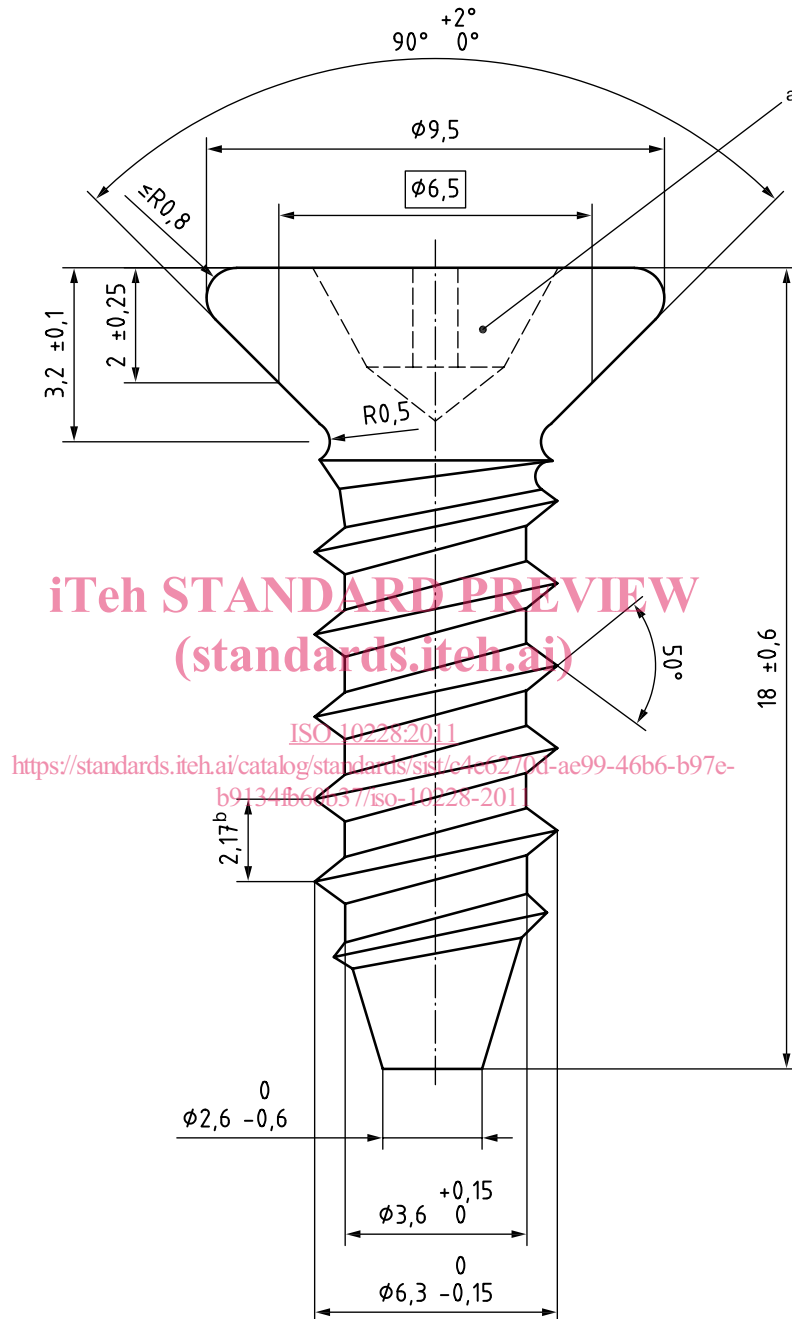

a Cross-recess type Z No. 3 in accordance with ISO 4757.

b Pitch.

Figure 1 — Head, thread and end configuration

## Bibliography

- [1] ISO 4042, *Fasteners — Electroplated coatings*
- [2] ISO 4757, *Cross recesses for screws*

**iTeh STANDARD PREVIEW**  
**(standards.iteh.ai)**

[ISO 10228:2011](https://standards.iteh.ai/catalog/standards/sist/c4e6270d-ae99-46b6-b97e-b9134fb60b37/iso-10228-2011)

<https://standards.iteh.ai/catalog/standards/sist/c4e6270d-ae99-46b6-b97e-b9134fb60b37/iso-10228-2011>



**iTeh STANDARD PREVIEW**  
**(standards.iteh.ai)**

ISO 10228:2011

<https://standards.iteh.ai/catalog/standards/sist/c4e6270d-ae99-46b6-b97e-b9134fb60b37/iso-10228-2011>