



Designation: D 6251/D 6251M – 07^{ε1}

Standard Specification for Wood-Cleated Panelboard Shipping Boxes¹

This standard is issued under the fixed designation D 6251/D 6251M; the number immediately following the designation indicates the year of original adoption or, in the case of revision, the year of last revision. A number in parentheses indicates the year of last reapproval. A superscript epsilon (ϵ) indicates an editorial change since the last revision or reapproval.

^{ε1} NOTE—Sections 4.1.3 and 6.2.3 were editorially corrected in August 2007.

1. Scope

1.1 This specification covers the fabrication and closure of empty and full wood-cleated, hereafter referred to as wood-cleated, panelboard boxes. These boxes are intended for use as containers for domestic and overseas shipment of general materials and supplies, not exceeding 1000 lb [454 kg] depending on box type (see 10.1).

1.2 Wood-cleated panelboard shipping box performance is dependent on its fabricated components and subsequent assembly; therefore, a variety of types, classes, styles, and treatments reflecting varied performance are specified. This specification, however, does not cover wood-cleated panelboard box performance under all atmospheric, handling, shipping, and storage conditions.

1.3 If the use of other construction methods or techniques is acceptable and permitted (see 5.1.17), the resulting packaging systems shall be of equal or better performance than would result from the use of these specified materials and procedures. The appropriate distribution cycle, specified in Practice D 4169, can be used to develop comparative procedures and criteria.

1.4 The values stated in either inch-pound units or SI units are to be regarded separately as standard. Within the text, the SI units are shown in brackets. The values stated in each system are not exact equivalents; therefore, each system must be used independently of the other. Combining values from the two systems may result in nonconformance with the standard. See IEEE/ASTM SI 10 for conversion of units.

1.5 *This standard does not purport to address all of the safety concerns, if any, associated with its use. It is the responsibility of the user of the standard to establish appropriate safety and health practices and determine the applicability of regulatory limitations prior to use.*

¹ This specification is under the jurisdiction of ASTM Committee D10 on Packaging and is the direct responsibility of Subcommittee D10.12 on Shipping Containers, Crates, Pallets, Skids and Related Structures.

Current edition approved June 1, 2007. Published July 2007. Originally approved in 1998. Last previous edition approved in 2001 as D 6251/D 6251M – 01.

2. Referenced Documents

2.1 ASTM Standards:²

D 996 Terminology of Packaging and Distribution Environments

D 1990 Practice for Establishing Allowable Properties for Visually-Graded Dimension Lumber from In-Grade Tests of Full-Size Specimens

D 3951 Practice for Commercial Packaging

D 3953 Specification for Strapping, Flat Steel and Seals

D 4169 Practice for Performance Testing of Shipping Containers and Systems

D 4727/D 4727M Specification for Corrugated and Solid Fiberboard Sheet Stock (Container Grade) and Cut Shapes

D 6199 Practice for Quality of Wood Members of Containers and Pallets

F 1667 Specification for Driven Fasteners: Nails, Spikes, and Staples

IEEE/ASTM SI 10 Standard for Use of the International System of Units (SI): The Modern Metric System

2.2 Federal Specifications:

A-A-58078 Plastic Board (For Packaging Applications)³

FF-F-133 Fasteners, Wood Joint, Corrugated – (Saw Edge)³

2.3 Code of Federal Regulations:

CFR Parts 107-180 Title 49, Hazardous Materials Regulations⁴

2.4 APA—The Engineered Wood Association:

PRP-108 Performance Standards and Policies for Structural-Use Panels⁵

PS 1-95 Construction and Industrial Plywood⁵

² For referenced ASTM standards, visit the ASTM website, www.astm.org, or contact ASTM Customer Service at service@astm.org. For *Annual Book of ASTM Standards* volume information, refer to the standard's Document Summary page on the ASTM website.

³ Available from the Federal Supply Service Bureau, Specification Section, Suite 8100, 480 L'Enfant Plaza, SW, Washington, DC 20408.

⁴ Available from the Superintendent of Documents, US Government Printing Office, Mail Stop: SSOP, Washington, DC 20402-9328.

⁵ Available from APA—The Engineered Wood Association, 7011 South 19th Street, Tacoma, WA 98466.

PS 2-04 Performance Standard for Wood-Based Structural-Use Panels⁵

2.5 *American Wood-Preservers' Association (AWPA):*

P8-99 Standard for Oil-Borne Preservatives⁶

P9-98 Standards for Solvents and Formulations for Organic Preservative Systems⁶

2.6 *American Softwood Lumber Standard:*

PS 20-05 American Softwood Lumber Standard⁷

2.7 *Hardwood Plywood and Veneer Association:*

HPVA HP-1-2004 Hardwood and Decorative Plywood⁸

2.8 *National Lumber Grades Authority (NLGA):*

Standard Grading Rules for Canadian Lumber, 1996 Edition, Printed Dec. 1, 1997⁹

2.9 *National Motor Freight Traffic Association:*

National Motor Freight Classification¹⁰

2.10 *Northeastern Lumber Manufacturers' Association (NELMA):*

Standard Grading Rules: NELMA¹¹

2.11 *Northern Softwood Lumber Bureau (NSLB):*

Standard Grading Rules: NSLB¹²

2.12 *Southern Pine Inspection Bureau (SPIB):*

1994 Grading Rules for Southern Yellow Pine¹³

2.13 *Uniform Classification Committee Standard:*

Uniform Freight Classification¹⁴

2.14 *West Coast Lumber Inspection Bureau (WCLIB):*

Standard Grading Rules Number 17 — WCLIB¹⁵

2.15 *Western Wood Products Association (WWPA):*

Western Lumber Grading Rules — 98¹⁶

4.1.4 *Type IV*—Oriented strand board (OSB) (only Style A, B, I, and J).

4.2 *Class:*

4.2.1 *Class 1*—Domestic (see 10.1.1).

4.2.2 *Class 2*—Overseas (see 10.1.2).

4.3 *Style (see Fig. 1 and 10.1):*

4.3.1 *Style A*—Standard box corner (see Fig. 2).

4.3.2 *Style A1*—Type I and II, Style A, modified with skids and when specified (see 5.1.3) unnailed top panel closure (see 4.6 and Fig. 3).

4.3.3 *Style B*—Interlocking three-way corners (see Fig. 4).

4.3.4 *Style C through K*—Limited only to Type II, Class 1 (see 5.1.2 and Fig. 1).

4.3.5 *Style A, B, I, and J*—Type III limited only to these styles (see 5.1.2 and Fig. 1)

4.4 *Water-Repellent Wood Preservative (see 5.1.13):*

4.4.1 *Treatment A*—Without water-repellent wood preservative.

4.4.2 *Treatment B*—With water-repellent wood preservative.

4.5 *Load Type (see 5.1.19 and 10.2):*

4.5.1 *Type 1*—Easy.

4.5.2 *Type 2*—Average.

4.5.3 *Type 3*—Difficult.

4.6 *Unnailed Top Panel Closure Option*—When specified (see 4.3.2 and 5.1.3), Type I and II, Style A1, or Type III and Type IV, Style A or B shall have the top panel modified (see 7.1.8) and closed with flat steel strapping as specified in the Supplemental Requirements. Securing the top panel to the box with other than flat steel strapping shall be prohibited.

3. Terminology

3.1 General definitions for packaging and distribution environments are found in Terminology D 996.

4. Classification

4.1 *Type (see 4.3):*

4.1.1 *Type I*—Corrugated plastic.

4.1.2 *Type II*—Corrugated and solid fiberboard.

4.1.3 *Type III*—Plywood.

⁶ Available from American Wood-Preservers' Association (AWPA), P.O. Box 361784, Birmingham, AL 35236-1784.

⁷ Available from National Institute of Standards and Technology (NIST), 100 Bureau Dr., Stop 1070, Gaithersburg, MD 20899-1070, <http://www.nist.gov>.

⁸ Available from Hardwood Plywood and Veneer Association (HPVA), P.O. Box 2789, Reston, VA 22090-0789, American National Standards Institute (ANSI) adopted.

⁹ Available from National Lumber Grades Authority (NLGA), #302-960 Quay-side Drive, New Westminster, B.C., Canada, V3M6G2.

¹⁰ Available from National Motor Freight Traffic Association (NMFTA), 2200 Mill Rd., Alexandria, VA 22314, <http://www.nmfta.org>.

¹¹ Available from Northeastern Lumber Manufacturers Association (NELMA), 272 Tuttle Road, P.O. Box 87A, Cumberland, ME 04021.

¹² Available from Northern Softwood Lumber Bureau (NSLB), 272 Tuttle Road, P.O. Box 87A, Cumberland, ME 04021.

¹³ Available from Southern Pine Inspection Bureau, 4709 Scenic Highway, Pensacola, FL 32504-9094.

¹⁴ Available from the Uniform Classification Committee, Tariff Publishing Office, 151 Ellis St. N.E., Suite 200, Atlanta, GA 30335-6021.

¹⁵ Available from West Coast Lumber Inspection Bureau (WCLIB), P.O. Box 23145, Portland, OR 97281.

¹⁶ Available from Western Wood Products Association, 522 SW Fifth Avenue, Suite 500, Portland, OR 97204-2122.

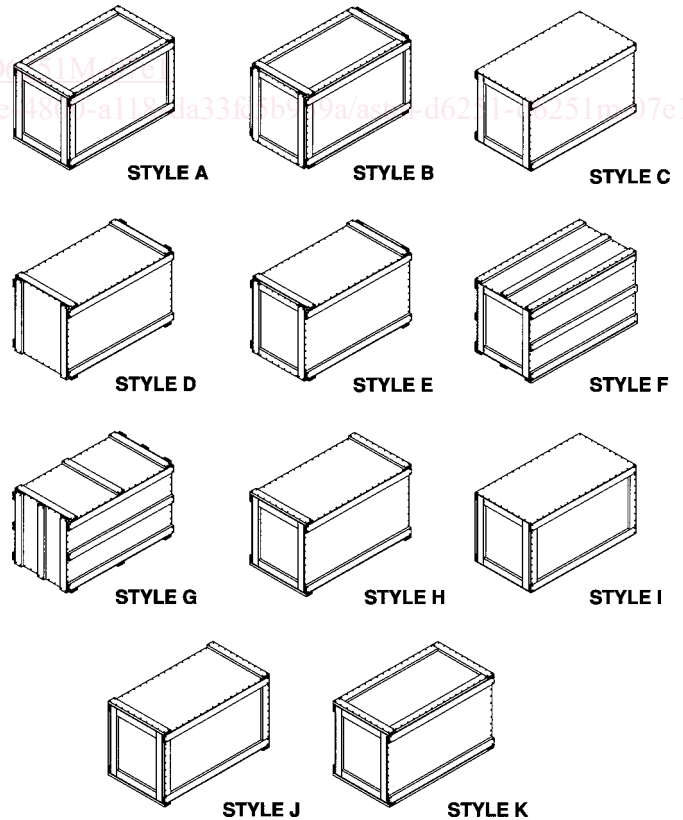
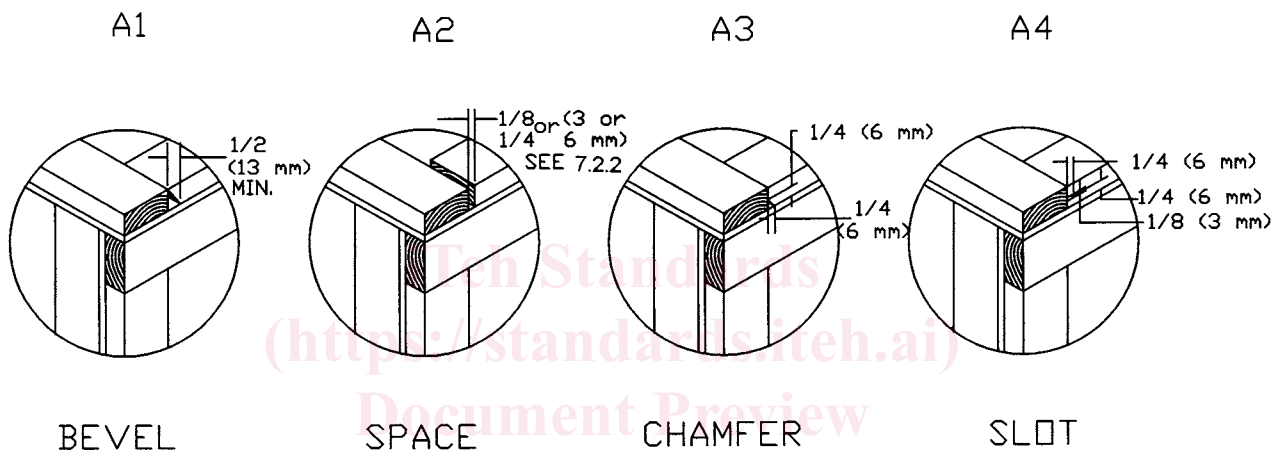
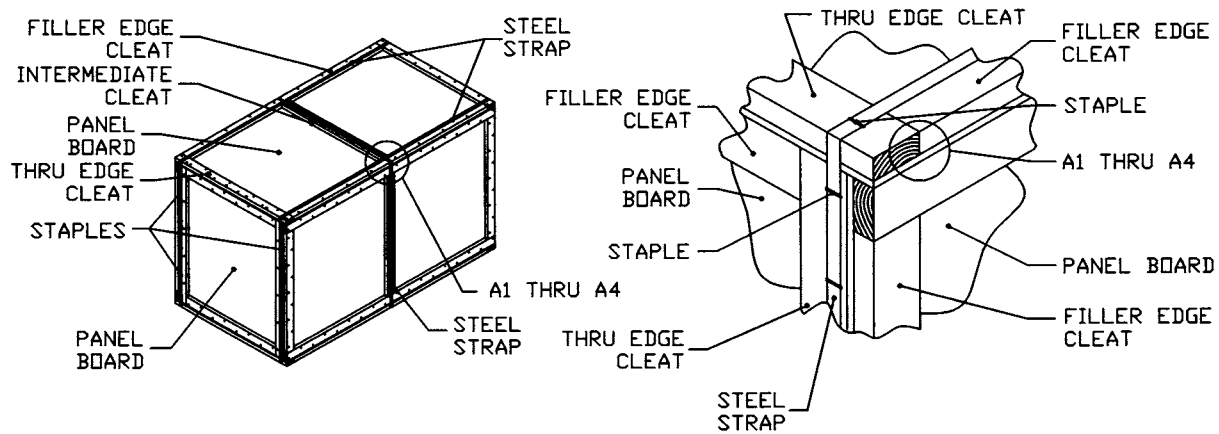

FIG. 1 Styles of Cleated Panel Boxes



A - FILLER AND INTERMEDIATE CLEAT ENDS AND RELATION TO THROUGH EDGE CLEATS

FIG. 2 Style A Box

4.7 Part Number—If required, a specification part number for boxes described in this specification can be formulated (see S3.3).

5. Ordering Information

5.1 Purchasers shall select the preferred permitted options and include the following information in procurement documents:

- 5.1.1 Specification title, number, and date.
- 5.1.2 Box type, class, style, preservative treatment, load type, and closure required (see 4.1-4.6, and 6.5).
- 5.1.3 When Type I and II, Style A1; or Type III and IV, Style A or B, unnailed top panel closure is required (see 4.3, 4.6, and 7.1.8).
- 5.1.4 Contents weight (see Tables 1-8).
- 5.1.5 Cleat lumber quality classification required (see 6.3).
- 5.1.6 Lumber quality used for skid fabrication (see 6.3).
- 5.1.7 Intermediate cleat requirements for Type III and IV, Class 1 and Class 2, Style I and J (see 7.2.2).

5.1.8 When skids are not required for boxes with gross weights of 200 lb [91 kg] or 100 lb [45 kg] with dimensions of 48 by 24 in. [1219 by 610 mm] or more (see 7.7.2).

- 5.1.9 When beveled skids are required (see 7.7.2).
- 5.1.10 When four-way entry skids are required and when 3½ by 4-in. [89 by 102-mm] built-up skids are required (see 7.7.3).
- 5.1.11 Whether container manufacturer's identification is required (see 7.8).
- 5.1.11.1 Whether modifications to container manufacturer's identification are required (see 7.8.6).
- 5.1.12 Box dimensions (inside measurements, panel to panel) specified in order of length by width by depth (see 7.5).
- 5.1.13 When water-repellent wood preservative treatment is required for plywood and cleats (see 4.4 and 6.5).
- 5.1.14 Whether boxes are to be shipped assembled or knocked-down (see 9.1).
- 5.1.15 When Class 1 boxes require external strapping (see S1.1).

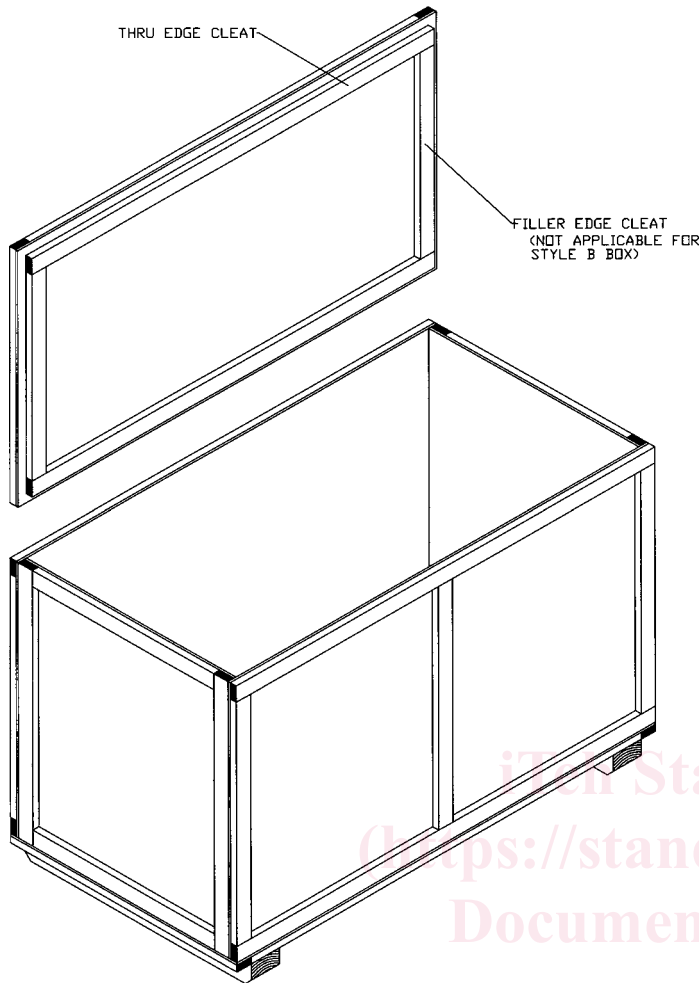

FIG. 3 Unnailed Top Panel Closure

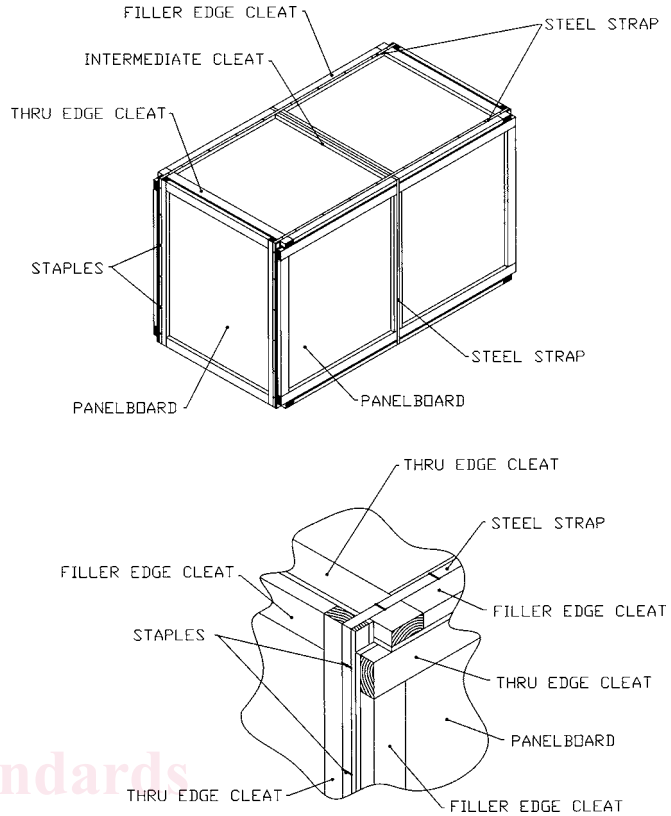

FIG. 4 Style B Box

TABLE 1 Type II Corrugated and Solid Fiberboard Requirements

Contents Weight Lb [kg]		Class 1		Class 2
Exceeding	Not Exceeding	CF D SW Grades ^A	SF D Grades ^A	SF Grades ^{A,B}
0	75	200	200	V3S or V4S
[0]	[34]			
75	150	275	275	V3S or V4S
[34]	[68]			
150	200	350	350	V3S or V4S
[68]	[91]			
200	300	350	350	...
[91]	[136]			
300	400	...	500	...
[136]	[181]			

^A As defined in Specification D 4727/D 4727M CF or SF (corrugated or solid fiberboard), D (domestic), SW (single-wall), grades as stated.

^B Class 2 boxes are limited to Style A or B and shall not exceed 48-in. [1219-mm] length, 36-in. [914-mm] width, or 36-in. [914-mm] depth.

5.1.15.1 When Class 2 boxes do not require strapping (see S1.1).

5.1.16 When seal joint specimens are required prior to strapping operations (see S3.1.1).

5.1.17 Whether other construction methods or techniques are acceptable and permitted (see 1.3).

5.1.17.1 Whether proof is required that other construction methods or techniques are acceptable (see 1.3).

5.1.18 Whether sanded plywood and cleats are required (see 6.2.3 and 6.5.3).

5.1.19 Load type (see 4.5).

5.1.20 Whether alternate fastening systems to secure the cleated box panels together are allowed (see 6.4.6).

6. Materials and Manufacture

6.1 *Materials*—It is encouraged that recycled material be used when practical. All recovered, recycled, or virgin materials used in the box manufacture shall meet the requirements of this specification and referenced documents. In addition, materials shall not affect or be affected by the product being packed. Type II panelboard shall have no more than 40 % post consumer recovered material.

6.2 *Panelboard*—Panelboard shall be as specified (5.1.2).

6.2.1 *Type I*—Panelboard shall be polyethylene, containing ½ % ultraviolet (UV) inhibitor and shall conform to A-A-

58078, Type II, or commercial equivalent. The plastic panel basis weight shall be 245 to 255 lb/1000 ft² [1195 to 1245 g/m²].

6.2.2 *Type II*—Panelboard shall be fiberboard conforming to Specification D 4727/D 4727M. Class 1 and Class 2 boxes, singlewall (SW), solid (SF), and V board shall conform to the requirements of 7.1.1.

6.2.3 *Type III*—Panelboard for Class 1 boxes shall conform to PS 1-95 Exposure 1 or Exterior panel; or ANSI/HPVA HP-1-2004. Panelboard for Class 2 boxes shall conform to PS 1-95 Exposure 1 or Exterior panel; or ANSI/HPVA HP-1-2004. Unless otherwise specified, plywood shall be unsanded. If smooth finish or sanded panels are required, appropriate

TABLE 2 Types III and IV, Class 1 Panel Requirements

Contents Weight lb [kg]		Panel Min Thickness ^A	
Exceeding	Not Exceeding	PS1-95, PS 2-04, and PRP-108 ^{B,C,D} in. [mm]	HPVA HP-1-04 ^{B,E} in. [mm]
0	75	5/16 ^{F,G}	1/8
[0]	[34]	[8]	[3.2]
75	150	5/16 ^{F,G}	1/8
[34]	[68]	[8]	[3.2]
150	300	5/16 ^{F,G}	3/16 ^F
[68]	[136]	[8]	[4.8]
300	500	5/16 ^F	3/16
[136]	[227]	[8]	[4.8]
500	800	5/16	1/4
[227]	[363]	[8]	[6.4]
800	1000	3/8	5/16
[363]	[454]	[9.5]	[8]

^A Commercial tolerances shall apply.

^B See 6.2.3.

^C Alternatively low-density plywood conforming to HPVA HP-1-2004 (see 6.2.3) may be used.

^D OSB panelboard conforming to APA PRP-108 or PS 2-04 and shall be limited to Style A, B, I, and J boxes.

^E Low density plywood conforming to HPVA HP-1-04 (see 6.2.3) shall not be used.

^F 3/20 in. [3.8 mm] min. thick plywood conforming to HPVA HP-1-2004, Type III, Grade 4, may be used in place of the 5/16 in. [8 mm]. (3/20-in. [3.8-mm] thick plywood is not a standard thickness in PS 1-95).

^G At the option of the supplier, 1/4-in. [6.4-mm] sanded plywood may be furnished.

sanded grades should be specified in the contract (see 5.1.18). The plywood thickness shall be specified in Tables 2 and 3. Plywood shall have no defects (knot holes, worm holes, and so forth) extending through the panel. When the plywood is specified to be surface treated with water-repellant wood preservative, the treatment shall be as specified in 6.5.

6.2.4 *Type IV*—Panelboard for Class 1 boxes shall conform to PS 2-04 Exposure 1 or Exterior panels. Panelboard for Class 2 boxes shall conform to PS 2-04 Exposure 1 or Exterior panels; or ANSI/HPVA HP-1-2004.

6.3 *Lumber*—As specified in 5.1.5, lumber cleats shall conform to Practice D 6199, Class 2, PS 20-05 or the NHLA rules. As specified in 5.1.6, skids shall conform to Practice D 6199 class 3, PS 20-05 or the NHLA rules.

6.4 *Fasteners*—Testing is not required for fasteners specified in 6.4.1-6.4.3 when used to join panelboard to wood in panel fabrication.

6.4.1 *Nails*—Nails shall be made of steel wire and shall conform to Specification F 1667 and as specified in 7.1 and 7.4.

6.4.2 *Staples or Wire Stitches*—Staples or wire stitches shall be made of steel wire not less than 0.0625 in. diameter (16 gauge), [1.59 mm]. The crown bearing surface (the underside) shall be not less than 5/16 in. [8 mm] long except that for Type II boxes the bearing surface shall be not less than 1/2 in. [13 mm] long.

6.4.3 *Single-Leg Fasteners*—Single-leg fasteners shall be formed automatically into a nail from sheared off bright, smooth, knurled, or helically fluted low-carbon steel. Medium carbon steel (stiff-stock) minimum 0.072-in. (15-gauge) [1.83-mm] diameter wire may also be used. Fasteners are driven subsequently by a special machine at a rapid rate, with sheared-bevel or sheared-square point. For Type I and II boxes,

the nail length, before driving, shall be a minimum of 1/8 in. [3 mm] longer than the thickness of the material being joined. For Type III and IV boxes, the nail length, before driving, shall be a minimum of 1/2 in. [13 mm] longer than the thickness of the material being joined. The automatic machine for driving shall be provided with needle-point knives, a J-clinch plate, and a 1/32-in. [1-mm] countersink. Single-leg fasteners shall not be used in joining panelboard to cleats.

6.4.4 *Other Fastenings*—Other single-leg fasteners, pre-formed or formed from wire, fastenings may be used to the extent specified in 7.1 but must be tested in accordance with 8.1. Steel wire used to form these fasteners shall have a diameter of not less than 0.0625 in. (16 gauge) [1.59 mm]. If wire other than round wire is used, the cross section area shall be equal to that of 0.0625 in. round wire. Fastener points and shanks shall be determined by the test specified in 8.1 for the applicable application and when driven, shall not split the wood members. The fastener withdrawal resistance shall be equal to nails specified in 6.4.1. These fasteners, when used, shall be driven so as to provide a minimum clinch of 1/8 in. [3 mm] and shall not be used with plywood and OSB less than 1/4 in. [6.4 mm] thick.

6.4.5 *Corrugated Fasteners*—Corrugated fasteners shall only be used on Type I and II boxes and shall conform to FF-F-133, or commercial equivalent, and as specified in 7.1.

6.4.6 *Alternate Fastening Systems*—If the use of alternate fastening systems is acceptable or permitted (see 5.1.20), these systems can be used to secure the box cleated panels together (see 7.6).

6.5 *Water-Repellent Wood Preservative*—Water-repellent wood preservative shall be composed of either a 2 % copper naphthenate, a 3 % zinc naphthenate, or a 1.8 % oxine copper (formerly referred to as copper-8-quinolinolate) solution. Treating solutions shall conform to AWWPA Standard P8 or P9.

6.5.1 *Type I and II*—When specified (see 4.4 and 5.1.13) Type I and II boxes shall have the wood cleats treated with a water-repellent wood preservative specified in 6.5 applied by immersion.

6.5.2 *Type III and IV*—Under some conditions of exposure, Type III and IV boxes may become stained and discolored by molds and mildew. Such staining is undesirable when the identification markings may become obscured. Water-repellent preservatives are effective in retarding mildew and similar stains. Type III and IV boxes shall be treated such that the plywood and OSB absorb not less than 2.2-lb/100 ft² [10.74 kg/100 m²] water-repellent wood preservative.

6.5.3 When sanded plywood and cleats are specified (see 5.1.18, and 6.2.3), the plywood shall be sanded prior to surface treatment. Wood shall be preserved by immersing in wood preservative for a minimum of three minutes prior to use in panel fabrication. There shall be evidence of discoloration of the plywood and wood cleats when tested in 8.4 for presence of preservative. The preservative shall be dry prior to assembling cleats to the panelboard or painting the cleats (see 6.5.5). When boxes are painted, wood preservation shall be accomplished prior to paint application.

6.5.4 In general, the copper naphthenate solution is the preferred wood preservative unless end items to be packaged in

TABLE 3 Type III and IV Class 2 Panel Requirements

Contents Weight lb [kg]		Panel Min Thickness ^A								
		Type 1 and 2 Loads				Type 3 Load				
Exceeding	Not Exceeding	PS1-95, PS 2–04, and PRP-108 ^{B,C} in. [mm]		HPVA HP-1-04 ^{B,D} in. [mm]		PS1-95, PS 2–04, and PRP-108 ^{B,C} in. [mm]			HPVA HP-1-04 ^{B,D} in. [mm]	
		Style		Style		Style			Style	
		A and B	I and J ^E	A and B	I and J ^E	A and B	I and J ^{E,F}	A and B	I and J ^{E,F}	
0	100	5/16 ^G	3/8	3/16 ^H	5/16	5/16 ^G	3/8	3/16 ^F	5/16	
[0]	[45]	[8]	[9.5]	[4.8]	[8]	[8]	[9.5]	[4.8]	[8]	
100	200	5/16 ^G	3/8	3/16 ^H	5/16	5/16 ^G	3/8	3/16	5/16	
[45]	[91]	[8]	[9.5]	[4.8]	[8]	[8]	[9.5]	[4.8]	[8]	
200	300	5/16 ^G	1/2	3/16	3/8	5/16	15/32	1/4	3/8	
[91]	[136]	[8]	[12.7]	[4.8]	[9.5]	[8]	[11.9]	[6.4]	[9.5]	
300	400	5/16 ^G	1/2	3/16	3/8	5/16	15/32	1/4	3/8	
[136]	[181]	[8]	[12.7]	[4.8]	[9.5]	[8]	[11.9]	[6.4]	[9.5]	
400	500	5/16 ^G	1/2	3/16	3/8	5/16	19/32	1/4	1/2	
[181]	[227]	[8]	[12.7]	[4.8]	[9.5]	[8]	[15.1]	[6.4]	[12.7]	
500	600	5/16	1/2	1/4	3/8	5/16	19/32	1/4	1/2	
[227]	[272]	[8]	[12.7]	[6.4]	[9.5]	[8]	[15.1]	[6.4]	[12.7]	
600	800	3/8	5/8	5/16	1/2	3/8	19/32	5/16	5/8	
[272]	[363]	[9.5]	[15.9]	[8]	[12.7]	[9.5]	[15.1]	[8]	[15.9]	
800	1000	3/8	5/8	5/16	1/2	1/2	19/32	3/8	5/8	
[363]	[454]	[9.5]	[15.9]	[8]	[12.7]	[12.7]	[15.1]	[9.5]	[15.9]	

^A Commercial tolerances shall apply.

^B See 6.2.3.

^C Alternatively low density plywood conforming to HPVA HP-1-2004 (see 6.2.3) may be used.

^D Low density plywood conforming to HPVA HP-1-04 (see 6.2.3) shall not be used.

^E Only Style I and J, top and bottom panels, all other panels as specified for Style A and B.

^F For Air Force shipments, Style I and J contents maximum weight shall be 150 lb [65 kg].

^G At the option of the supplier, 1/4-in. [6.3-mm] sanded plywood may be furnished.

^H 3/20-in. [3.8 mm] min. thick plywood conforming to HPVA HP-1-2004, Type I, Grade 4, may be used in place of the 3/16-in. [4.8-mm] thick plywood. (3/20-in. [3.8-mm] thick plywood is not a standard thickness in PS 1-95 or PS 2–04).

TABLE 4 Cleat Sizes for Type I Panels

Contents Weight lb [kg]		Class 1 Cleat Size in. [mm] ^A		Class 2 Cleat Size in. [mm] ^A	
Exceeding	Not Exceeding	Min Width	Min Thickness	Min Width	Min Thickness
		0	100	1 3/4	3/4
[0]	[45]	[35]	[16]	[35]	[16]
100	150	1 3/4	3/4	2 1/4	3/4
[45]	[68]	[35]	[16]	[45]	[16]
150	225	2 5/8	3/4	2 5/8	3/4
[68]	[102]	[54]	[16]	[54]	[16]
225	250	3	3/4	3	3/4
[102]	[113]	[64]	[16]	[64]	[16]
250	300	3	3/4	3	3/4
[113]	[136]	[64]	[16]	[64]	[16]
300	350	3	3/4	3	3/4
[136]	[159]	[64]	[16]	[64]	[16]
350	400	3	3/4	3	3/4
[159]	[181]	[64]	[16]	[64]	[16]
400	500	3	3/4
[181]	[227]	[64]	[16]		

^A Practice D 6199 dimension requirements apply.

TABLE 5 Cleat Sizes for Type II Panels

Contents Weight lb [kg]		Class 1			
Box Style	Exceeding	Not Exceeding	Min Cleat Size, min ^A		
			Thickness	Width	Width
			Group I and II Woods in. [mm]	Group III and IV Woods in. [mm]	All Groups of Woods in. [mm]
C thru K	0	75	1 1/16	5/8	1 1/2
	[0]	[34]	[16]	[14]	[32]
C thru K	74	150	3/4	1 1/16	1 11/16
	[35]	[68]	[16]	[16]	[37]
A and B	0	75	5/8	9/16	1 1/2
	[0]	[34]	[14]	[13]	(32)
A and B	75	150	1 1/16	5/8	1 11/16
	[34]	[68]	[16]	[14]	[37]
A and B	150	300	3/4	1 1/16	1 3/4
	[68]	[136]	[16]	[16]	[35]
A and B	300	400	1	1 3/16	1 3/4
	[136]	[181]	[19]	[16]	[35]

Contents Weight lb [kg]		Cleat Min Size for all Wood Groups in. [mm] ^A	
Box Style	Exceeding	Thickness, min	Width, min
A or B Only	0	200	1 3/4
	[0]	[91]	[35]

^A Practice D 6199 dimension requirements apply.

these boxes are food items not packaged in sealed metal cans or materials which might be adversely effected by residual solvents from the wood preservative. The purchaser should be consulted if there is a question concerning the appropriate wood preservative (see 5.1.2).

6.5.5 *Preservative Dryness*—Boxes, or box parts, shall be dried prior to assembling or painting after water-repellent