



## Standard Test Method for Fire-Resistive Joint Systems<sup>1</sup>

This standard is issued under the fixed designation E 1966; the number immediately following the designation indicates the year of original adoption or, in the case of revision, the year of last revision. A number in parentheses indicates the year of last reapproval. A superscript epsilon ( $\epsilon$ ) indicates an editorial change since the last revision or reapproval.

### INTRODUCTION

Joint systems are positioned in joints, voids, gaps, or other discontinuities between or bounded by two or more supporting elements. Normally such openings are denoted as “linear” because the length is greater than their width—defined by a typical ratio of at least 10:1 as in practice. Joints are present in buildings as a result of:

- (i) Design to accommodate various movements induced by thermal differentials, seismicity, and wind loads and exist as a clearance separation.
- (ii) Acceptable dimensional tolerances between two or more building elements, for example, between non-loadbearing walls and floors.
- (iii) Inadequate design, inaccurate assembly, repairs or damage to the building.

### 1. Scope

1.1 This fire-test-response test method measures the performance of joint systems designed to be used with fire rated floors and walls during a fire endurance test exposure. The fire endurance test end point is the period of time elapsing before the first performance criteria is reached when the joint system is subjected to one of two time-temperature fire exposures.

1.2 The fire exposure conditions used are either those specified by Test Method E 119 for testing assemblies to standard time-temperature exposures or Test Method E 1529 for testing assemblies to rapid-temperature rise fires.

1.3 This test method specifies the heating conditions, methods of test, and criteria for the evaluation of the ability of a joint system to maintain the fire resistance where hourly rated fire-separating elements meet.

1.4 Test results establish the performance of joint systems during the fire-exposure period and shall not be construed as having determined the joint systems suitability for use after that exposure.

1.5 This test method does not provide quantitative information about the joint system relative to the rate of leakage of smoke or gases or both. However, it requires that such phenomena be noted and reported when describing the general behavior of joint systems during the fire endurance test but is not part of the conditions of compliance.

1.6 Potentially important factors and fire characteristics not addressed by this test method include, but are not limited to:

1.6.1 The performance of the fire-resistive joint system constructed with components other than those tested.

1.6.2 The cyclic movement capabilities of joint systems other than the cycling conditions tested.

1.7 The values stated in inch-pound units are to be regarded as the standard. The SI values given in parentheses are for information only.

1.8 The text of this standard references notes and footnotes which provide explanatory material. These notes and footnotes (excluding those in tables and figures) shall not be considered as requirements of the standard.

1.9 *This standard is used to measure and describe the response of materials, products, or assemblies to heat and flame under controlled conditions, but does not by itself incorporate all factors required for fire hazard or fire risk assessment of the materials, products, or assemblies under actual fire conditions.*

1.10 *This standard does not purport to address all of the safety concerns, if any, associated with its use. It is the responsibility of the user of this standard to establish appropriate safety and health practices and determine the applicability of regulatory limitations prior to use.*

<sup>1</sup> This test method is under the jurisdiction of ASTM Committee E05 on Fire Standards and is the direct responsibility of Subcommittee E05.11 on Fire Endurance. Current edition approved October 10, 2001. Published January 2002. Originally published as E 1966-98. Last previous edition E 1966-00 on Fire Resistance. Current edition approved Aug. 1, 2007. Published August 2007. Originally approved in 1998. Last previous edition approved in 2001 as E 1966-01.

## 2. Referenced Documents

### 2.1 ASTM Standards:<sup>2</sup>

E 84 [Test Method for Surface Burning Characteristics of Building Materials](#)

E 119 [Test Methods for Fire Tests of Building Construction and Materials](#)

E 176 [Terminology of Fire Standards](#)

E 631 [Terminology of Building Constructions](#)

E 1529 [Test Methods for Determining Effects of Large Hydrocarbon Pool Fires on Structural Members and Assemblies<sup>2</sup>](#)

### 2.2 Other Documents:

UL 385 [Standard for Play Pipes for Water Supply Testing in Fire-Protection Service](#) [Test Methods for Determining Effects of Large Hydrocarbon Pool Fires on Structural Members and Assemblies](#)

E 2226 [Practice for Application of Hose Stream](#)

E 2307 [Test Method for Determining Fire Resistance of Perimeter Fire Barriers Using Intermediate-Scale, Multi-story Test Apparatus](#)

## 3. Terminology

3.1 For the purpose of this standard, the definitions given in Terminologies E 176 and E 631, together with the following, apply:

3.1.1 *fire-separating element, n*—floors, walls, and partitions having a period of fire resistance determined in accordance with Test Methods E 119 or E 1529.

3.1.2 *fire resistive joint system, n*—a device or designed feature that provides a fire separating function along continuous linear openings, including changes in direction, between or bounded by fire separating elements.

3.1.3 *joint, n*—the linear void located between juxtaposed fire-separating elements.

3.1.4 *maximum joint width, n*—the widest opening of an installed joint system.

3.1.5 *minimum joint width, n*—the narrowest opening of an installed joint system.

3.1.6 *movement cycle, n*—the change between the minimum and the maximum joint widths of a joint system.

3.1.7 *nominal joint width, n*—the specified opening of a joint in practice that is selected for test purposes.

3.1.8 *splice, n*—the connection or junction within the length of a joint system.

3.1.9 *supporting construction, n*—the arrangement of building sections forming the fire-separating elements into which the joint systems are installed.

3.1.10 *test assembly, n*—the complete assembly of test specimens together with their supporting construction.

3.1.11 *test specimen, n*—a joint system of a specific material(s), design, and width.

## 4. Summary of Test Method

4.1 This test method describes the following test sequence and procedure:

4.1.1 When the maximum joint width does not equal the minimum joint width, joint systems shall be movement cycled before being fire tested.

4.1.2 Joint systems and their supporting construction shall be conditioned and fire tested.

4.1.3 A duplicate test specimen, that is an extension of a wall, is subject to a fire of lesser duration than the fire endurance/resistance rating. After which, the duplicate test specimen is subject to the hose stream test.

## 5. Significance and Use

5.1 This test method evaluates, under the specified test conditions: (1) the ability of a fire resistive joint system to undergo movement without reducing the fire rating of the adjacent fire separating elements and (2) the duration for which test specimens will contain a fire and retain their integrity during a predetermined test exposure.

5.2 This test method provides for the following measurements and evaluations where applicable:

5.2.1 Capability of the joint system to movement cycle.

5.2.2 Loadbearing capacity of the joint system.

5.2.3 Ability of the joint system to prohibit the passage of flames and hot gases.

5.2.4 Transmission of heat through the joint system.

5.2.5 Ability of the joint system, that is an extension of a wall, to resist the passage of water during a hose stream test.

5.3 This test method does not provide the following:

5.3.1 Evaluation of the degree by which the joint system contributes to the fire hazard by generation of smoke, toxic gases, or other products of combustion.

5.3.2 Measurement of the degree of control or limitation of the passage of smoke or products of combustion through the joint system.

5.3.3 Measurement of flame spread over the surface of the joint system.

<sup>2</sup> For referenced ASTM standards, visit the ASTM website, [www.astm.org](http://www.astm.org), or contact ASTM Customer Service at [service@astm.org](mailto:service@astm.org). For *Annual Book of ASTM Standards* Vol 04.07 volume information, refer to the standard's Document Summary page on the ASTM website.

NOTE 1—The information in 5.3.1-5.3.3 may be determined by other suitable fire test methods. For example, 5.3.3 may be determined by Test Method E 84.

5.3.4 Evaluation of joints formed by the rated or non-rated exterior walls and the floors of the building.

5.4 In this procedure, the test specimens are subjected to one or more specific sets of laboratory test conditions. When different test conditions are substituted or the end-use conditions are changed, it is not always possible by, or from, this test method to predict changes to the characteristics measured. Therefore, the results are valid only for the exposure conditions described in this test method.

**6. Apparatus**

6.1 *Cycling Apparatus*—Equipment (or device) capable of being used to induce movement of a joint system and meeting the required cyclic rate and number of cycles selected from Table 1.

6.2 *Furnace*—An enclosed furnace facility capable of controlling a fire to the time-temperature curve in Test Methods E 119 or E 1529. An example of a vertical furnace with a test frame is shown in Fig. 1 and a horizontal furnace is shown in Fig. 2.

6.3 *Furnace Thermocouples*:

6.3.1 The E 119 furnace thermocouples shall:

6.3.1.1 Be protected by sealed porcelain tubes having a nominal 3/4-in. (19-mm) outside diameter and 1/8-in. (3-mm) wall thickness, or, as an alternative, in the case of base metal thermocouples, protected by a standard 1/2-in. (13-mm) diameter wrought steel or wrought iron pipe of standard weight, and

6.3.1.2 Have a time constant between the range of 5.0 to 7.2 min while encased in the tubes described in 6.3.1.1.

6.3.2 Other types of E 119 protection tubes or pyrometers shall be used only when they give the same indications under test conditions as those of 6.3.1.2 within the limit of accuracy that applies for furnace-temperature measurements.

NOTE 2—A typical thermocouple assembly meeting these time constant requirements may be fabricated by fusion-welding the twisted ends of No. 18 gage Chromel-Alumel wires, mounting the leads in porcelain insulators and inserting the assembly so the thermocouple bead is approximately 0.5 in. (25 mm) from the sealed end of the standard weight nominal 1/2-in. (25-mm) iron, steel, or Inconel<sup>3</sup> pipe. The time constant for this and for several other thermocouple assemblies was measured in 1976. The time constant may also be calculated from knowledge of its physical and thermal properties.<sup>4</sup>

6.3.3 The E 1529 furnace thermocouples shall measure the temperature of the gases adjacent to and impinging on the test specimens using factory manufactured 1/4-in. (6-mm) outside diameter (OD), Inconel-sheathed, Type K, Chromel-Alumel thermocouples. The time constant, in air, of the thermocouple assemblies shall be less than 60 s. Standard calibration thermocouples with an accuracy of ± 0.75 % shall be used.

6.4 *Pressure-sensing Probes*—Where applicable, tolerances are ± 5 % of dimensions shown in Fig. 3 or Fig. 4.

6.4.1 The pressure-sensing probes shall be either:

6.4.1.1 A T-shaped sensor as shown in Fig. 3, or

6.4.1.2 A tube sensor as shown in Fig. 4.

6.5 *Unexposed Surface Thermocouples* :

6.5.1 The wires for the unexposed thermocouple in the length covered by the thermocouple pad are not to be heavier than No. 18 AWG (0.82 mm<sup>2</sup>) and are to be electrically insulated with heat-resistant and moisture-resistant coatings.

6.6 *Thermocouple Pads*:

6.6.1 The properties of thermocouple pads used to cover each thermocouple on the unexposed side of the test assembly shall have the following characteristics.

6.6.1.1 They shall be dry, felted refractory fiber pads.

<sup>2</sup> Annual Book of ASTM Standards, Vol 04.11.

<sup>3</sup> Inconel is a registered trade name of INCO Alloys, Inc., 3800 Riverside Dr., Huntington, WV 25720.

<sup>4</sup> Underwriters Laboratories, 333 Pfingston Road, Northbrook, IL 60062.

<sup>4</sup> Supporting data is available from ASTM International Headquarters. Request RR: E05-1001.

**TABLE 1 Conditions of Test Specimen Cycling**

NOTE 1—The terms used for movement are indicative of the cyclic rate in expansion and contraction of the joint system and not of the magnitude or direction of movement.

Movement Type	Minimum Cycling Rates (cpm)	Minimum Number of Movement Cycles
Type I—Thermal	1	500
Type II—Wind Sway	10	500
Type III—Seismic	30	100
Type IV—Combined Movement	30	100
followed by:	10	400

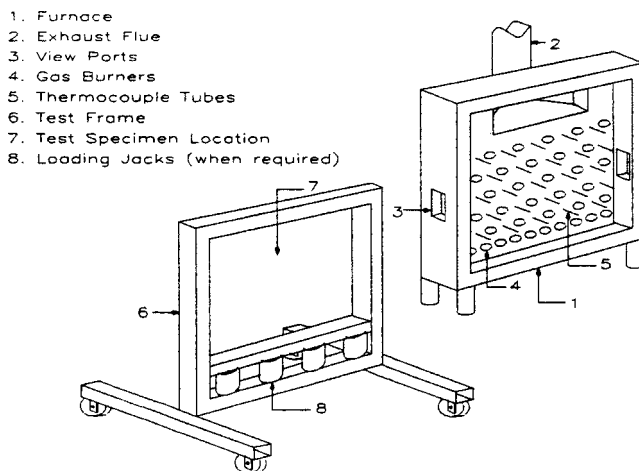

FIG. 1 Example of Vertical Furnace and Test Frame

1. Furnace  
2. Exhaust Flue  
3. View Ports  
4. Access Door  
5. Gas Burners  
6. Thermocouple Tube Locations  
7. Test Specimen Location

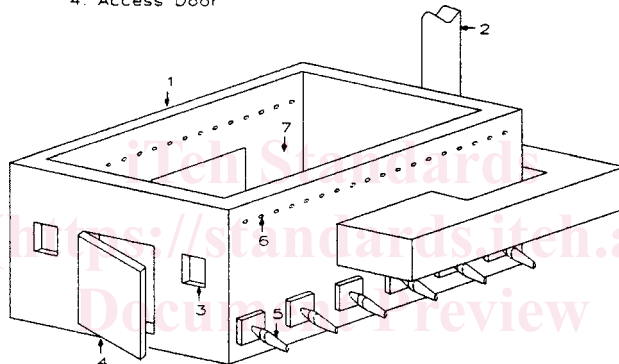

FIG. 2 Example of Horizontal Furnace

6.6.1.2 For joints having a maximum joint width of less than 6 in. (152 mm) the length and width of the square pad shall measure  $2 \pm 0.04$  in. ( $50 \pm 1$  mm). For joints having a maximum joint width equal to or greater than 6 in. (152 mm) the length and width of the square pad shall measure  $6 \pm 0.12$  in. ( $152 \pm 3$  mm).

6.6.1.3 The thermocouple pads shall be  $0.375 \pm 0.063$  in. ( $9.5 \pm 1.6$  mm) thick. The thickness measurement is to be made under the light load of a standard  $\frac{1}{2}$ -in. (12.7-mm) diameter pad of a dial micrometer gauge.

6.6.1.4 The thermocouple pads shall have a density of  $31.2 \pm 0.6$  lbs/ft<sup>3</sup> ( $500 \pm 10$  kg/m<sup>3</sup>).

6.6.1.5 The thermal conductivity of the thermocouple pads at 150°F (66°C) shall be  $0.37 \pm 0.03$  Btu -in./h -ft<sup>2</sup> -°F [ $0.053 \pm 0.004$  W/(m -K)].

6.6.1.6 The thermocouple pads shall have a hardness (on soft face) of 2.25 to 4.5 (modified Brinnell). The hardness measurement is to be made by pressing a standard 1-in. (25-mm) diameter steel ball against the specimen and measuring the indentation obtained between a minor load of 2 pounds-mass (0.91 kg) and an additional major load of 10 pounds-mass (4.5 kg) [12 pounds-mass (5.4 kg) total load]. The hardness is obtained by the relationship:

$$\text{Hardness} = 2.24/y$$

where:

y = the difference in indentation [in. (mm)].

#### 6.7 Differential Pressure Measurement Instruments:

6.7.1 The differential pressure measurement instrument shall be:

6.7.1.1 A manometer or equivalent transducer.

6.7.1.2 Capable of reading in graduated increments of no greater than 0.01 in H<sub>2</sub>O (2.5 Pa) with a precision of not less than  $\pm 0.005$  in. H<sub>2</sub>O ( $\pm 1.25$  Pa).

#### 6.8 Cotton Pads:

6.8.1 Their nominal size shall be 4 by 4 by  $\frac{3}{4}$  in. (100 by 100 by 19 mm). Cotton pads are to consist of new, undyed and soft cotton fibers, without any admixture of artificial fibers. Each cotton pad is to weigh approximately 3 to 4 g. The cotton pads are to be conditioned prior to use by drying in an oven at  $212 \pm 9^\circ\text{F}$  ( $100 \pm 5^\circ\text{C}$ ) for at least 30 min. After drying, the cotton pads

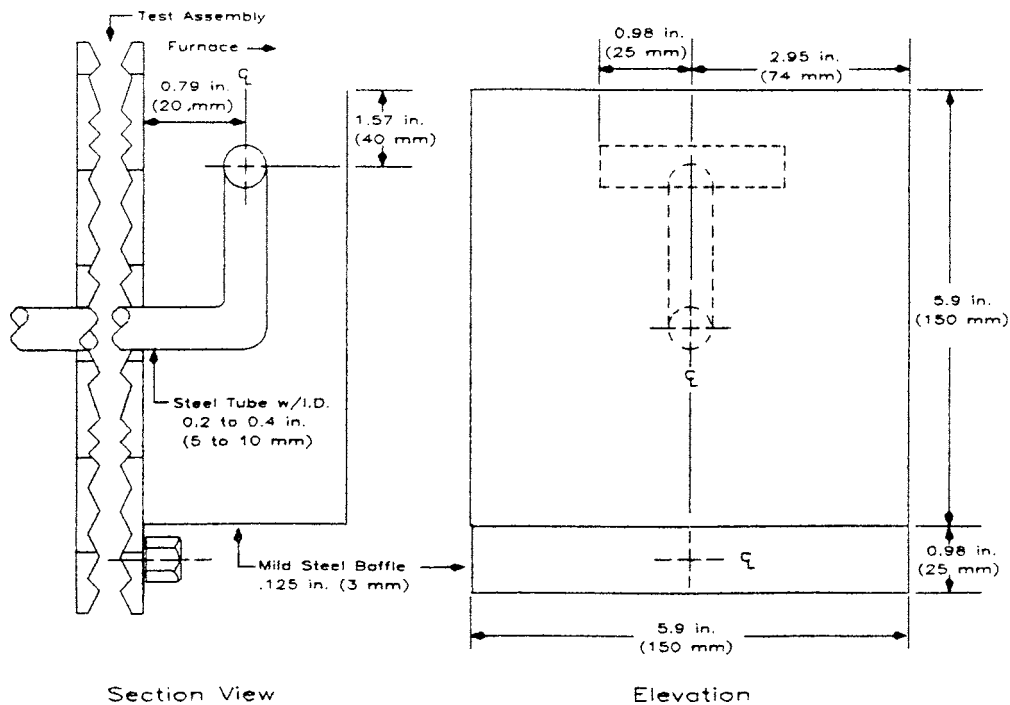

FIG. 3 "T" Shaped Pressure Sensing Probe

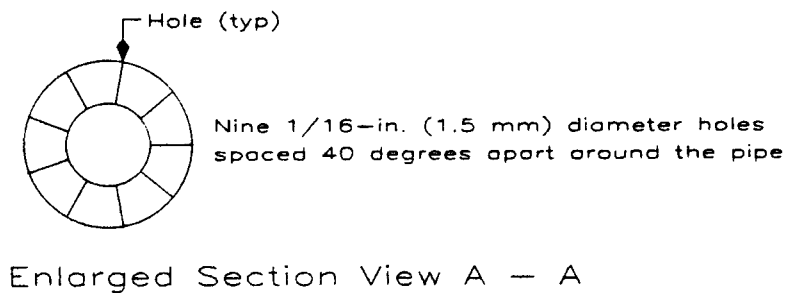
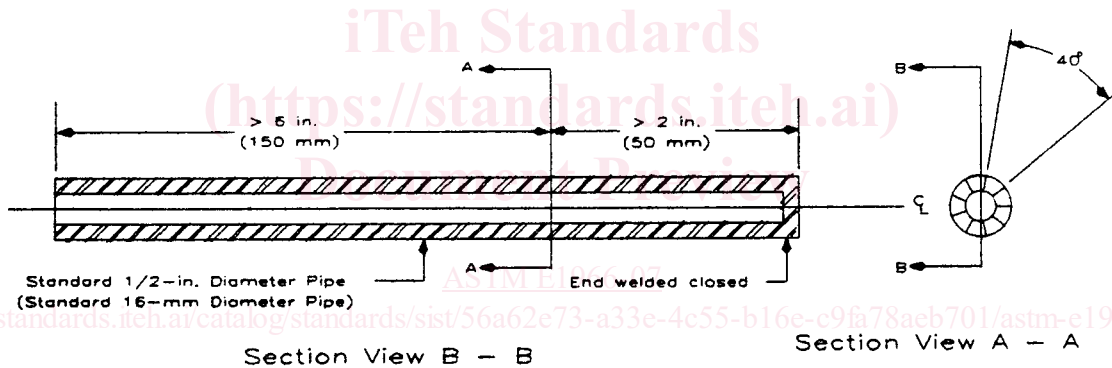

FIG. 4 Tube Type Pressure Sensing Probe

shall be stored in a desiccator for up to 24 h.

6.8.2 The frame used to hold the cotton pad is to be formed of No. 16 AWG (1.31-mm) steel wire and is to be provided with a handle long enough to reach all points of the test assembly.

6.9 Loading System:

6.9.1 Equipment, or a device, capable of inducing a desired load upon the joint system or supporting construction. An example of a loading system is shown in Fig. 5.

6.10 Hose Stream Delivery System :

6.10.1 The hose stream delivery system shall consist of:

6.10.1.1 A standard 2 1/2-in. (64-mm) diameter hose attached to a national standard play pipe as described in UL-385 Practice E 2226.

1. Steel "I" Beam
2. Pneumatic or Hydraulic Cylinders
3. Universal Clamping Joint
4. Variable Size Base

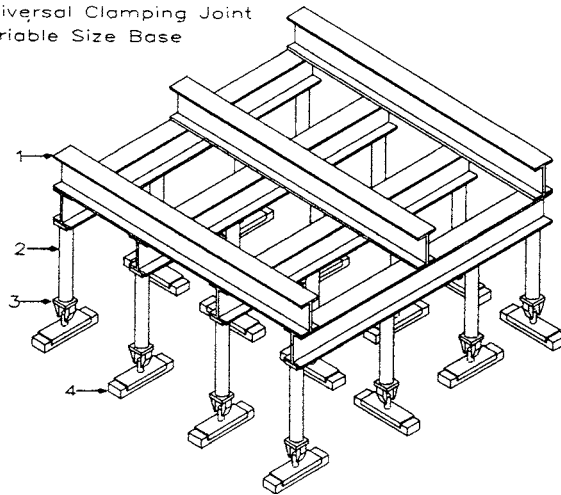

FIG. 5 Example of Loading System

6.10.1.2 The play pipe shall have a length of  $30 \pm 0.25$  in. ( $762 \pm 6$  mm) and shall be equipped with a standard  $1 \frac{1}{8}$ -in. (29-mm) discharge tip of the standard-taper-smooth-bore pattern without shoulder at the orifice.

6.10.1.3 The play pipe shall be fitted with a standard  $2 \frac{1}{2}$ -in. (64-mm) inside dimension by 6-in. (153-mm) long nipple mounted between the hose and the base of the play pipe.

6.10.1.4 A pressure tap for measuring the water pressure at the base of the nozzle shall be normal to the surface of the nipple, shall be centered in its length, and shall not protrude into the water stream.

6.10.1.5 A suitable pressure gage capable of reading a minimum of 0-50 psi (0-344.8 kPa) and graduated into no greater than 2-psi (13.8-kPa) increments shall be used to measure the water pressure.

## 7. Test Specimen

7.1 Make the test assembly representative of the construction for which the fire endurance resistance rating is desired with respect to materials, workmanship, and details. Install the test specimen in accordance with the manufacturer's specified procedure for conditions representative of those found in building construction.

7.2 A test assembly often consists of multiple test specimen widths, joint configurations, test specimen configurations, supporting elements, and joint face materials. When multiple test specimens are installed and tested simultaneously in a test assembly, maintain the separation between adjacent test specimens to accommodate thermocouple placement and structural and loading requirements.

7.3 Test each test specimen with manufactured and field splices. When the technique of the manufactured splice is the same as the field splice, test only one splice. Make the minimum distance between a splice and the nearest furnace wall 1.5 times the thickness of the supporting construction or 12 in. (305 mm) whichever is greater. Make the minimum separation between splices within a test specimen 36 in. (914 mm). Position splices so that they will be exposed to a minimum positive furnace pressure differential of 0.01 in H<sub>2</sub>O (2.5 Pa) during the fire exposure test.

7.4 Test all test specimens at their maximum joint width.

7.5 Test vertical asymmetrical test specimens from both sides unless they are designed for fire exposure on only one side or it is documented that the side with the lower fire endurance resistance rating is being tested.

7.6 Make vertical and horizontal test specimens with a maximum joint width not greater than 4 in. (102 mm) at least 4 ft (1219 mm).

7.7 For maximum joint widths greater than 4 in. (102 mm), make the vertical test specimens at least 9 ft (2744 mm) and make the horizontal test specimens at least 12 ft (3658 mm).

7.8 Asymmetrical wall-to-wall joint systems shall be tested in accordance with 7.5. Examples of asymmetrical and symmetrical wall-to-wall joint systems are illustrated in Fig. 6.

## 8. Preparation of Apparatus

### 8.1 Furnace Thermocouples:

8.1.1 *Test Method E 119*—Make the exposed length of the pyrometer tube and thermocouple in the furnace chamber not less than 12 in. (305 mm).

8.1.2 *Test Method E 1529*—Mount a minimum length of 20 diameters (125 mm) of the sheathed junction end of the thermocouple parallel to the surface of the test specimen.

### 8.2 Furnace Thermocouple Locations :